

# HP Series High Pressure Fittings

**Hy-Lok**

Pressures to 60.000 psig

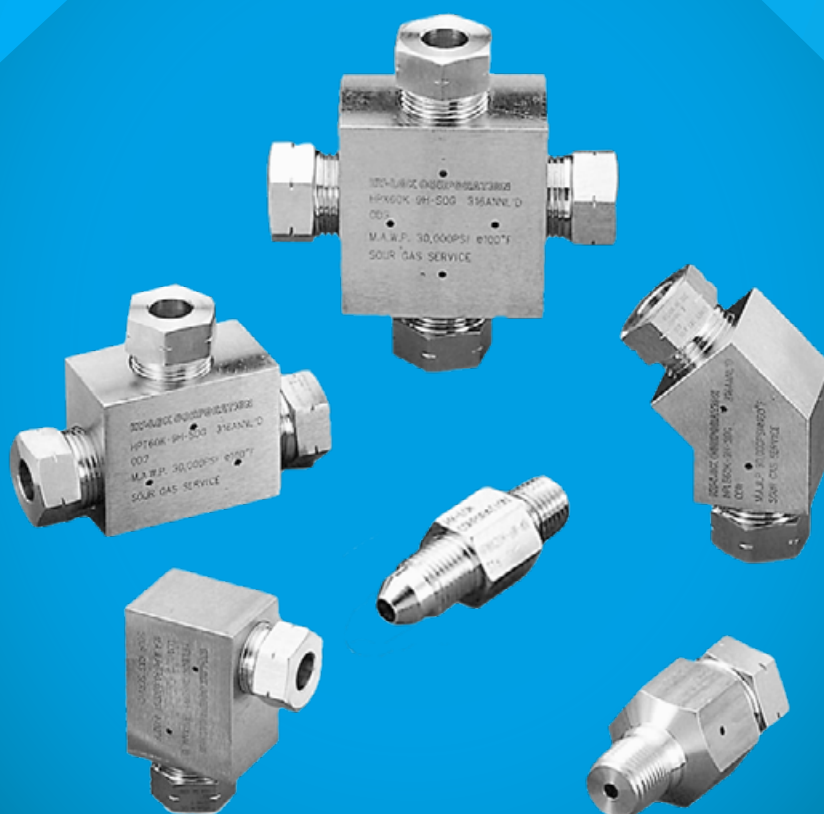







**FLOWTEKNIK**  
SCANDINAVIA APS



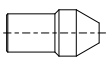
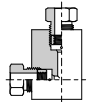
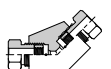
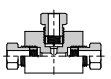





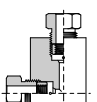
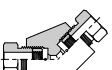

# HP Series High Pressure Fittings

## Medium Pressure Fittings Pressure to 20,000psig



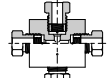



Glands		3
Collars		3
Plugs		3
Elbows		4
45° Elbows		4
Tees		4
Crosses		5
Straight Couplings		5
Union Couplings (Slip Type)		5

## Sour Gas Service Fittings Pressure to 10,000psig



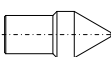
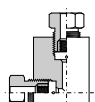

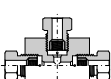
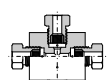
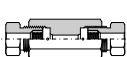
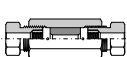
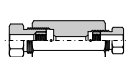
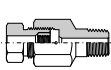



Glands		6
Collars		6
Plugs		6
Elbows		7
45° Elbows		7
Tees		7

Crosses		8
Straight Couplings		8
Union Couplings (Slip Type)		8
Nipples		9

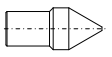
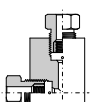
## High Pressure Fittings Pressure to 60,000psig

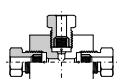
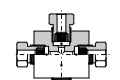
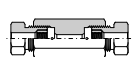
Glands		10
Collars		10
Plugs		10
Elbows		11
45° Elbows		11
Tees		11
Crosses		12
Straight Couplings		12
Union Couplings (Slip Type)		12
Reducing Couplings		13
Male Connectors (H/P Tube to Pipe)		13
Female Connectors (H/P Tube to Pipe)		13

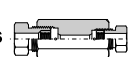
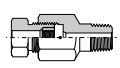
## Sour Gas Service Fittings Pressure to 30,000psig

Glands		14
Collars		14
Plugs		14
Elbows		15
45° Elbows		15
Tees		15
Crosses		16
Straight Couplings		16
Union Couplings (Slip Type)		16
Reducing Couplings		17
Male Connectors (H/P Tube to Pipe)		17
Female Connectors (H/P Tube to Pipe)		17
Nipples		18

## Installation Instruction

General	19
What's the Difference	
Coning and Threading of Tubing	20
Assembly and Makeup of Connection	

## Installation Tools

Coning Tool	
Threading Tool	21
Tube Vise	

## Ordering Information

Catalog Numbering System	22
How to order	

## Medium Pressure Fittings Pressure to 20,000psig

A complete range of elbows, tees, and crosses is available for all of the tubing connection sizes. Material is high tensile 316 stainless steel, Standard tubing glands and collars are provided unless otherwise specified.

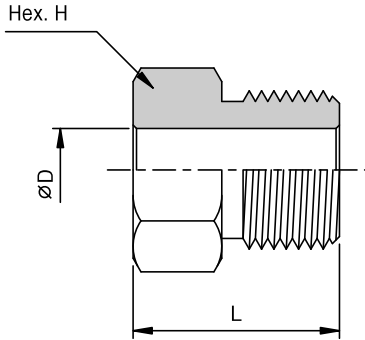

### Glands

Unit : mm

Catalog No.	Pressure Rating psig	Tube Size	A	L	H
HPG20K-4M	20,000	1/4"	6.4	14.2	12.7
HPG20K-6M	20,000	3/8"	9.5	18.3	15.7
HPG20K-9M	20,000	9/16"	14.3	25.4	22.4
HPG20K-12M	20,000	3/4"	19.1	23.9	28.4
HPG20K-16M	20,000	1"	25.4	35.1	35.1

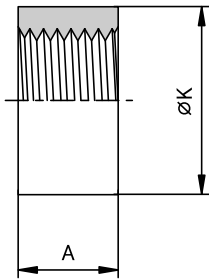

### Collars

Unit : mm

Catalog No.	Pressure Rating psig	Tube Size	A	K
HPC20K-4M	20,000	1/4"	5.6	9.7
HPC20K-6M	20,000	3/8"	6.4	11.9
HPC20K-9M	20,000	9/16"	7.9	18.3
HPC20K-12M	20,000	3/4"	9.7	23.9
HPC20K-16M	20,000	1"	12.7	31.8

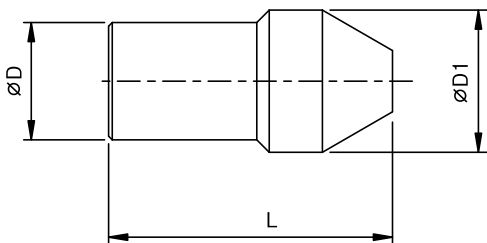

### Plugs

Unit : mm

Catalog No.	Pressure Rating psig	Tube Size	D	L	D <sub>1</sub>
HPP20K-4M	20,000	1/4"	6.4	25.4	9.7
HPP20K-6M	20,000	3/8"	9.5	31.8	11.9
HPP20K-9M	20,000	9/16"	14.3	39.6	18.3
HPP20K-12M	20,000	3/4"	19.1	41.1	23.9
HPP20K-16M	20,000	1"	25.4	55.6	31.8

ALL DIMENSIONS ARE FOR REFERENCE ONLY, SUBJECT TO CHANGE.

# Medium Pressure Fittings Pressure to 20,000psig

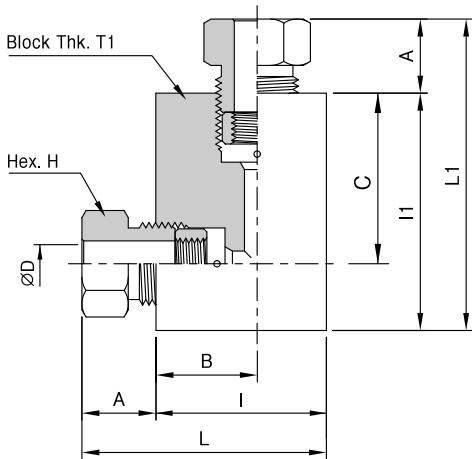

## Elbows

Unit : mm

Catalog No.	Pressure Rating psig	Tube Size	D	A	B	C	I	I <sub>1</sub>	L	L <sub>1</sub>	H	T <sub>1</sub>
HPL20K-4M	20,000	1/4"	6.4	9.7	19.1	19.1	28.4	38.1	38.1	47.8	12.7	15.7
HPL20K-6M	20,000	3/8"	9.5	11.9	25.4	25.4	35.1	50.8	47.0	62.7	15.7	19.1
HPL20K-9M	20,000	9/16"	14.3	13.5	31.8	31.8	44.5	63.5	58.0	77.0	22.4	25.4
HPL20K-12M	20,000	3/4"	19.1	15.7	38.1	38.1	57.2	76.2	72.9	91.9	28.4	35.0
HPL20K-16M	20,000	1"	25.4	18.3	52.3	52.3	76.2	104.6	94.5	122.9	35.1	44.5

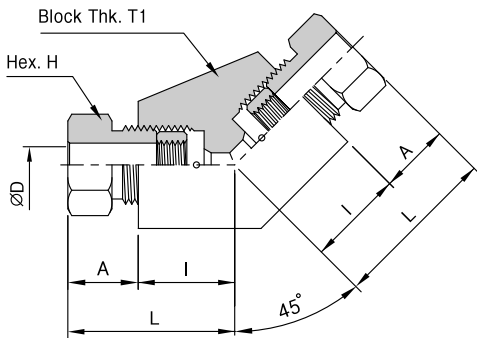

## 45° Elbows

Unit : mm

Catalog No.	Pressure Rating psig	Tube Size	D	A	I	L	H	T <sub>1</sub>
HPLB20K-4M	20,000	1/4"	6.4	9.1	19.1	28.8	12.7	15.7
HPLB20K-6M	20,000	3/8"	9.5	11.9	25.4	37.3	15.7	19.1
HPLB20K-9M	20,000	9/16"	14.3	13.5	31.8	45.3	22.4	25.4
HPLB20K-12M	20,000	3/4"	19.1	15.7	38.1	53.8	28.4	35.0
HPLB20K-16M	20,000	1"	25.4	18.3	52.3	70.6	35.1	44.5

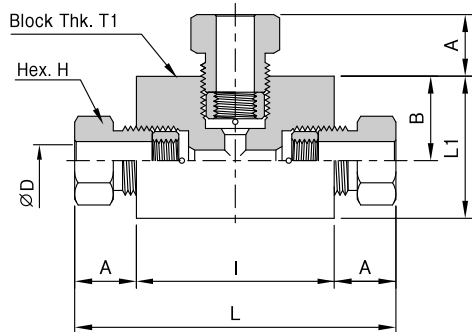

## Tees

Unit : mm

Catalog No.	Pressure Rating psig	Tube Size	D	A	B	I	L <sub>1</sub>	L	H	T <sub>1</sub>
HPT20K-4M	20,000	1/4"	6.4	9.7	19.1	38.1	28.4	57.5	12.7	15.7
HPT20K-6M	20,000	3/8"	9.5	11.9	25.4	50.8	35.0	74.6	15.7	19.1
HPT20K-9M	20,000	9/16"	14.3	13.5	31.8	63.5	44.5	90.5	22.4	25.4
HPT20K-12M	20,000	3/4"	19.1	15.7	38.1	76.2	57.2	107.6	28.4	35.0
HPT20K-16M	20,000	1"	25.4	18.3	52.3	104.6	76.2	141.2	35.1	44.5

# Medium Pressure Fittings Pressure to 20,000psig

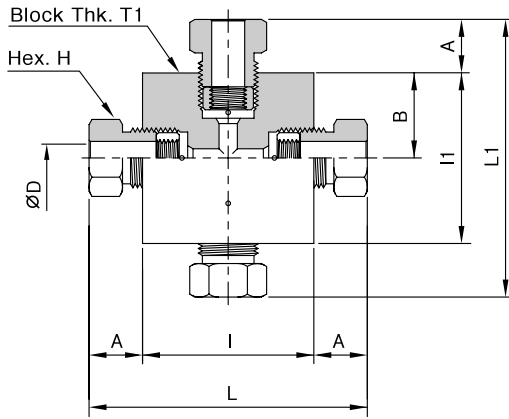

## Crosses

Unit : mm

Catalog No.	Pressure Rating psig	Tube Size	D	A	B	I	I <sub>1</sub>	L	L <sub>1</sub>	H	T <sub>1</sub>
HPX20K-4M	20,000	1/4"	6.4	9.7	19.1	38.1	38.1	57.5	57.5	12.7	15.7
HPX20K-6M	20,000	3/8"	9.5	11.9	25.4	50.8	50.8	74.6	74.6	15.7	19.1
HPX20K-9M	20,000	9/16"	14.3	13.5	31.8	63.5	63.5	90.5	90.5	22.4	25.4
HPX20K-12M	20,000	3/4"	19.1	15.7	38.1	76.2	76.2	107.6	107.6	28.4	35.0
HPX20K-16M	20,000	1"	25.4	18.3	52.3	104.6	104.6	141.2	141.2	35.1	44.5

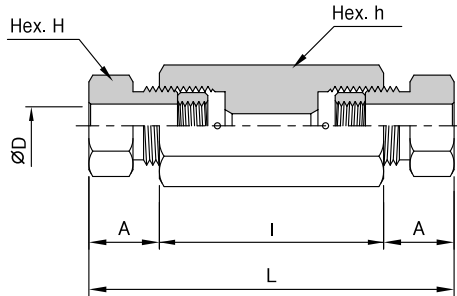

## Straight Couplings

Unit : mm

Catalog No.	Pressure Rating psig	Tube Size	D	A	I	L	h	H
HPF20K-4M	20,000	1/4"	6.4	9.7	35.1	54.5	15.7	12.7
HPF20K-6M	20,000	3/8"	9.5	11.9	44.5	68.3	19.1	15.7
HPF20K-9M	20,000	9/16"	14.3	13.5	53.8	80.8	25.4	22.4
HPF20K-12M	20,000	3/4"	19.1	15.7	63.5	94.9	35.0	28.4
HPF20K-16M	20,000	1"	25.4	18.3	88.9	125.5	44.5	35.1

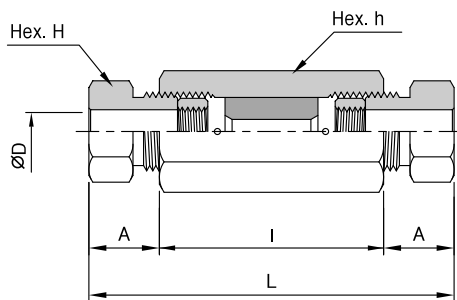

## Union Couplings(Slip Type)

Unit : mm

Catalog No.	Pressure Rating psig	Tube Size	D	A	I	L	h	H
HPUF20K-4M	20,000	1/4"	6.4	9.7	35.1	54.5	15.7	12.7
HPUF20K-6M	20,000	3/8"	9.5	11.9	44.5	68.3	19.1	15.7
HPUF20K-9M	20,000	9/16"	14.3	13.5	53.8	80.8	25.4	22.4
HPUF20K-12M	20,000	3/4"	19.1	15.7	63.5	94.9	35.0	28.4
HPUF20K-16M	20,000	1"	25.4	18.3	88.9	125.5	44.5	35.1

## Sour Gas Service Fittings Pressure to 10,000psig

Hy-Lok High pressure Fittings are designed to resist in sour environment and rated for a maximum working pressure of 10,000psig at 100°F.

Material for wetted parts are selected in accordance with NACE MR-0175 for sulfide stress cracking resistant materials.

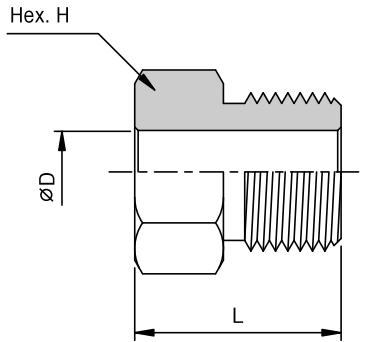

### Glands

Unit : mm

Catalog No.	Pressure Rating psig	Tube Size	D	L	H
HPG10K-4M-SOG	10,000	1/4"	6.4	14.2	12.7
HPG10K-6M-SOG	10,000	3/8"	9.5	18.3	15.7
HPG10K-9M-SOG	10,000	9/16"	14.3	25.4	22.4
HPG10K-12M-SOG	10,000	3/4"	19.1	23.9	28.4
HPG10K-16M-SOG	10,000	1"	25.4	35.1	35.1

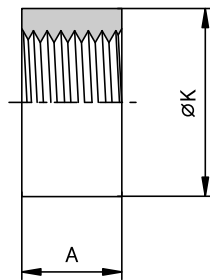

### Collars

Unit : mm

Catalog No.	Pressure Rating psig	Tube Size	A	K
HPC10K-4M-SOG	10,000	1/4"	5.6	9.7
HPC10K-6M-SOG	10,000	3/8"	6.4	11.9
HPC10K-9M-SOG	10,000	9/16"	7.9	18.3
HPC10K-12M-SOG	10,000	3/4"	9.7	23.9
HPC10K-16M-SOG	10,000	1"	12.7	31.8

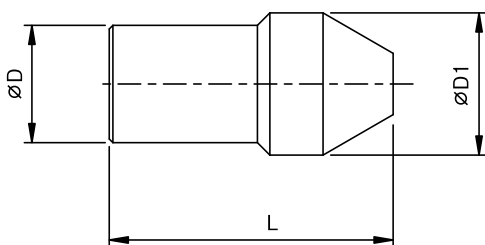

### Plugs

Unit : mm

Catalog No.	Pressure Rating psig	Tube Size	D	L	D <sub>1</sub>
HPP10K-4M-SOG	10,000	1/4"	6.4	25.4	9.7
HPP10K-6M-SOG	10,000	3/8"	9.5	31.8	11.9
HPP10K-9M-SOG	10,000	9/16"	14.3	39.6	18.3
HPP10K-12M-SOG	10,000	3/4"	19.1	41.1	23.9
HPP10K-16M-SOG	10,000	1"	25.4	55.6	31.8

ALL DIMENSIONS ARE FOR REFERENCE ONLY, SUBJECT TO CHANGE.

# Sour Gas Service Fittings Pressure to 10,000psig

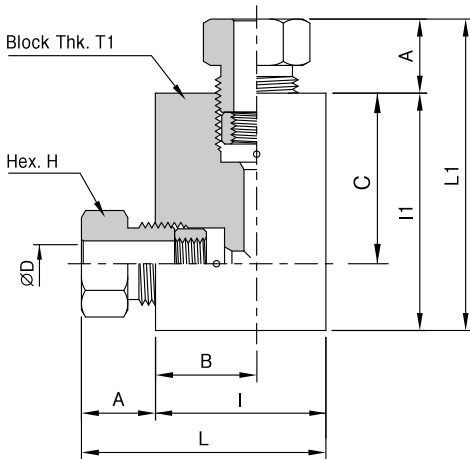

## Elbows

Unit : mm

Catalog No.	Pressure Rating psig	Tube Size	D	A	B	C	I	I <sub>1</sub>	L	L <sub>1</sub>	H	T <sub>1</sub>
HPL10K-4M-SOG	10,000	1/4"	6.4	9.7	19.1	19.1	28.4	38.1	38.1	47.8	12.7	15.7
HPL10K-6M-SOG	10,000	3/8"	9.5	11.9	25.4	25.4	35.1	50.8	47.0	62.7	15.7	19.1
HPL10K-9M-SOG	10,000	9/16"	14.3	13.5	31.8	31.8	44.5	63.5	58.0	77.0	22.4	25.4
HPL10K-12M-SOG	10,000	3/4"	19.1	15.7	38.1	38.1	57.2	76.2	72.9	91.9	28.4	35.0
HPL10K-16M-SOG	10,000	1"	25.4	18.3	52.3	52.3	76.2	104.6	94.5	122.9	35.1	44.5

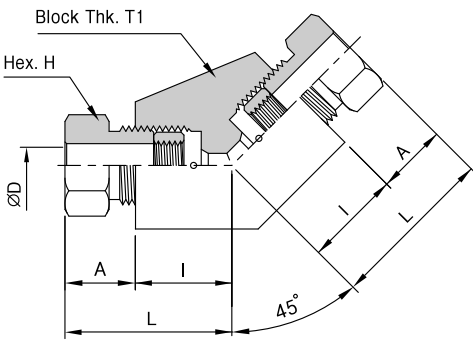

## 45° Elbows

Unit : mm

Catalog No.	Pressure Rating psig	Tube Size	D	A	I	L	H	T <sub>1</sub>
HPLB10K-4M-SOG	10,000	1/4"	6.4	9.1	19.1	28.8	12.7	15.7
HPLB10K-6M-SOG	10,000	3/8"	9.5	11.9	25.4	37.3	15.7	19.1
HPLB10K-9M-SOG	10,000	9/16"	14.3	13.5	31.8	45.3	22.4	25.4
HPLB10K-12M-SOG	10,000	3/4"	19.1	15.7	38.1	53.8	28.4	35.0
HPLB10K-16M-SOG	10,000	1"	25.4	18.3	52.3	70.6	35.1	44.5

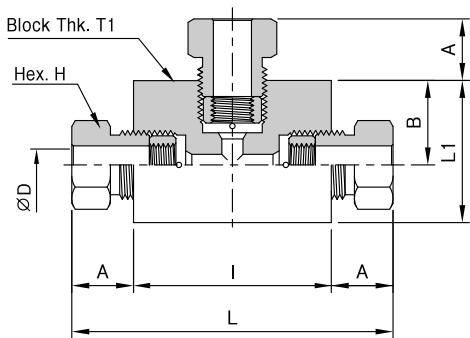

## Tees

Unit : mm

Catalog No.	Pressure Rating psig	Tube Size	D	A	B	I	L <sub>1</sub>	L	H	T <sub>1</sub>
HPT10K-4M-SOG	10,000	1/4"	6.4	9.7	19.1	38.1	28.4	57.5	12.7	15.7
HPT10K-6M-SOG	10,000	3/8"	9.5	11.9	25.4	50.8	35.0	74.6	15.7	19.1
HPT10K-9M-SOG	10,000	9/16"	14.3	13.5	31.8	63.5	44.5	90.5	22.4	25.4
HPT10K-12M-SOG	10,000	3/4"	19.1	15.7	38.1	76.2	57.2	107.6	28.4	35.0
HPT10K-16M-SOG	10,000	1"	25.4	18.3	52.3	104.6	76.2	141.2	35.1	44.5

ALL DIMENSIONS ARE FOR REFERENCE ONLY, SUBJECT TO CHANGE.

# Sour Gas Service Fittings Pressure to 10,000psig

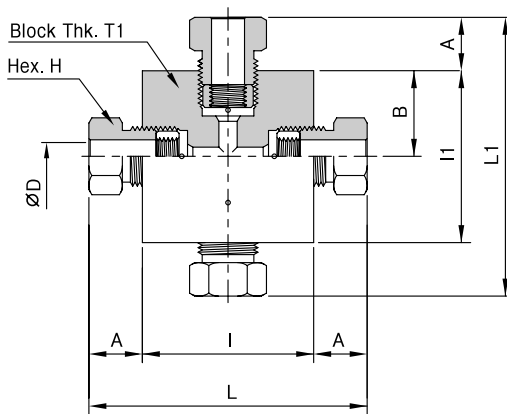

## Crosses

Unit : mm

Catalog No.	Pressure Rating psig	Tube Size	D	A	B	I	I1	L	L1	H	T1
HPX10K-4M-SOG	10,000	1/4"	6.4	9.7	19.1	38.1	38.1	57.5	57.5	12.7	15.7
HPX10K-6M-SOG	10,000	3/8"	9.5	11.9	25.4	50.8	50.8	74.6	74.6	15.7	19.1
HPX10K-9M-SOG	10,000	9/16"	14.3	13.5	31.8	63.5	63.5	90.5	90.5	22.4	25.4
HPX10K-12M-SOG	10,000	3/4"	19.1	15.7	38.1	76.2	76.2	107.6	107.6	28.4	35.0
HPX10K-16M-SOG	10,000	1"	25.4	18.3	52.3	104.6	104.6	141.2	141.2	35.1	44.5

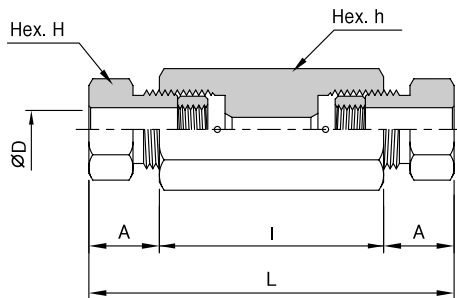

## Straight Couplings

Unit : mm

Catalog No.	Pressure Rating psig	Tube Size	D	A	I	L	h	H
HPF10K-4M-SOG	10,000	1/4"	6.4	9.7	35.1	54.5	15.7	12.7
HPF10K-6M-SOG	10,000	3/8"	9.5	11.9	44.5	68.3	19.1	15.7
HPF10K-9M-SOG	10,000	9/16"	14.3	13.5	53.8	80.8	25.4	22.4
HPF10K-12M-SOG	10,000	3/4"	19.1	15.7	63.5	94.9	35.0	28.4
HPF10K-16M-SOG	10,000	1"	25.4	18.3	88.9	125.5	44.5	35.1

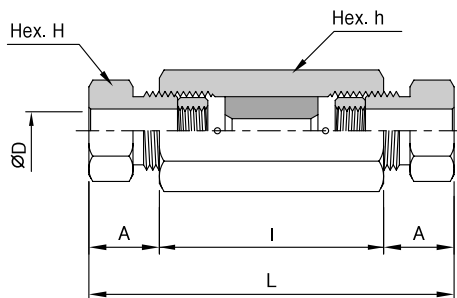

## Union Couplings(Slip Type)

Unit : mm

Catalog No.	Pressure Rating psig	Tube Size	D	A	I	L	h	H
HPUF10K-4M-SOG	10,000	1/4"	6.4	9.7	35.1	54.5	15.7	12.7
HPUF10K-6M-SOG	10,000	3/8"	9.5	11.9	44.5	68.3	19.1	15.7
HPUF10K-9M-SOG	10,000	9/16"	14.3	13.5	53.8	80.8	25.4	22.4
HPUF10K-12M-SOG	10,000	3/4"	19.1	15.7	63.5	94.9	35.0	28.4
HPUF10K-16M-SOG	10,000	1"	25.4	18.3	88.9	125.5	44.5	35.1

ALL DIMENSIONS ARE FOR REFERENCE ONLY, SUBJECT TO CHANGE.



## Nipples

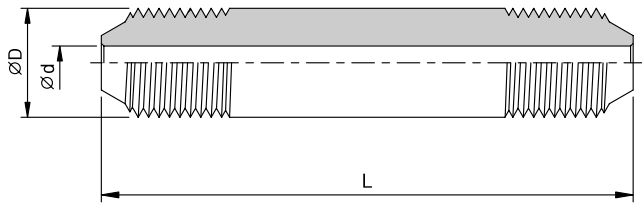

### Special Lengths

In addition to the standard lengths cataloged in the table below, nipples are available in any custom length. Consult factory.

### Materials

Catalog numbers in table refer to Type 316 stainless steel.  
Type 304 stainless steel nipples available. Consult factory.

## Pressure to 20,000psig

Catalog No.							Tube Size (inches)		Working Pressure at 100°F psig
2.75" Length(L)	3" Length(L)	4" Length(L)	6" Length(L)	8" Length(L)	10" Length(L)	12" Length(L)	O.D(D)	I.D(d)	
HPNP20K-4M02L	HPNP20K-4M03L	HPNP20K-4M04L	HPNP20K- 4M06L	HPNP20K- 4M08L	HPNP20K- 4M10L	HPNP20K- 4M12L	1/4"	0.109"	20,000
	HPNP20K-6M03L	HPNP20K-6M04L	HPNP20K- 6M06L	HPNP20K- 6M08L	HPNP20K- 6M10L	HPNP20K- 6M12L	3/8"	0.203"	20,000
		HPNP20K-9M04L	HPNP20K- 9M06L	HPNP20K- 9M08L	HPNP20K- 9M10L	HPNP20K- 9M12L	9/16"	0.312"	20,000
			HPNP20K-12M06L	HPNP20K-12M08L	HPNP20K-12M10L	HPNP20K-12M12L	3/4"	0.438"	20,000
			HPNP20K-16M06L	HPNP20K-16M08L	HPNP20K-16M10L	HPNP20K-16M12L	1"	0.562"	20,000

## Pressure to 10,000psig for Sour Gas Service Fittings

Catalog No.							Tube Size (inches)		Working Pressure at 100°F psig
2.75" Length(L)	3" Length(L)	4" Length(L)	6" Length(L)	8" Length(L)	10" Length(L)	12" Length(L)	O.D(D)	I.D(d)	
HPNP10K-4M02L-SOG	HPNP10K-4M03L-SOG	HPNP10K-4M04L-SOG	HPNP10K- 4M06L-SOG	HPNP10K- 4M08L-SOG	HPNP10K- 4M10L-SOG	HPNP10K- 4M12L-SOG	1/4"	0.109"	10,000
	HPNP10K-6M03L-SOG	HPNP10K-6M04L-SOG	HPNP10K- 6M06L-SOG	HPNP10K- 6M08L-SOG	HPNP10K- 6M10L-SOG	HPNP10K- 6M12L-SOG	3/8"	0.203"	10,000
		HPNP10K-9M04L-SOG	HPNP10K- 9M06L-SOG	HPNP10K- 9M08L-SOG	HPNP10K- 9M10L-SOG	HPNP10K- 9M12L-SOG	9/16"	0.312"	10,000
			HPNP10K-12M06L-SOG	HPNP10K-12M08L-SOG	HPNP10K-12M10L-SOG	HPNP10K-12M12L-SOG	3/4"	0.438"	10,000
			HPNP10K-16M06L-SOG	HPNP10K-16M08L-SOG	HPNP10K-16M10L-SOG	HPNP10K-16M12L-SOG	1"	0.562"	10,000

ALL DIMENSIONS ARE FOR REFERENCE ONLY, SUBJECT TO CHANGE.

## High Pressure Fittings Pressure to 60,000psig

A complete range of elbows, tees, and crosses is available for all of the tubing connection sizes. Material high tensile 316 stainless steel, Standard tubing glands and collars are provided unless otherwise specific

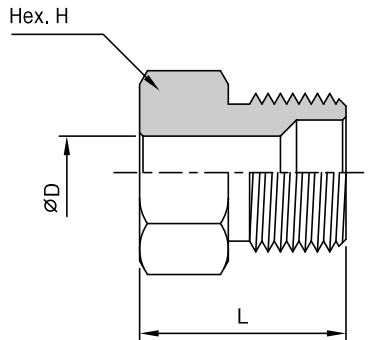

### Glands

Unit : mm

Catalog No.	Pressure Rating psig	Tube Size	D	L	H
HPG60K-2H	60,000	1/8"	3.2	19.1	12.7
HPG60K-4H	60,000	1/4"	6.4	22.6	15.9
HPG60K-6H	60,000	3/8"	9.5	30.1	20.6
HPG60K-9H	60,000	9/16"	14.3	38.1	30.2

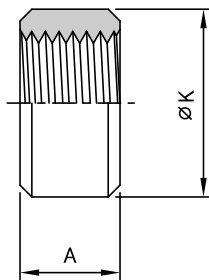

### Collars

Unit : mm

Catalog No.	Pressure Rating psig	Tube Size	A	K
HPC60K-2H	60,000	1/8"	7.9	6.4
HPC60K-4H	60,000	1/4"	9.5	9.5
HPC60K-6H	60,000	3/8"	12.7	12.7
HPC60K-9H	60,000	9/16"	15.7	20.6

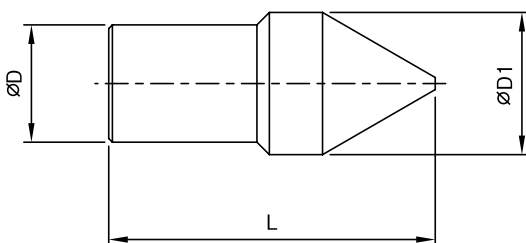

### Plugs

Unit : mm

Catalog No.	Pressure Rating psig	Tube Size	D	L	D <sub>1</sub>
HPP60K-2H	60,000	1/8"	3.2	22.2	6.4
HPP60K-4H	60,000	1/4"	6.4	29.2	9.7
HPP60K-6H	60,000	3/8"	9.5	39.6	12.7
HPP60K-9H	60,000	9/16"	14.3	51.0	20.5

ALL DIMENSIONS ARE FOR REFERENCE ONLY, SUBJECT TO CHANGE.

# High Pressure Fittings Pressure to 60,000psig

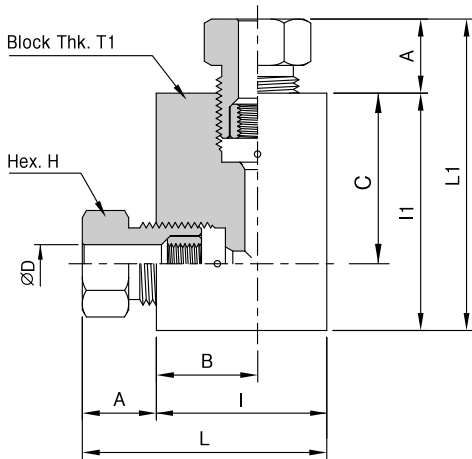

## Elbows

Unit : mm

Catalog No.	Pressure Rating psig	Tube Size	D	A	B	C	I	I <sub>1</sub>	L	L <sub>1</sub>	H	T <sub>1</sub>
HPLB60K-2H	60,000	1/8"	3.2	10.5	19.1	19.1	28.6	28.6	39.1	39.1	12.7	19.1
HPLB60K-4H	60,000	1/4"	6.4	12.7	15.7	22.4	25.4	38.1	38.1	50.1	15.9	19.1
HPLB60K-6H	60,000	3/8"	9.5	13.5	25.4	31.8	38.1	50.1	51.6	63.6	20.6	25.4
HPLB60K-9H	60,000	9/16"	14.3	20.5	28.4	47.8	47.8	66.5	68.3	87.0	30.2	38.0

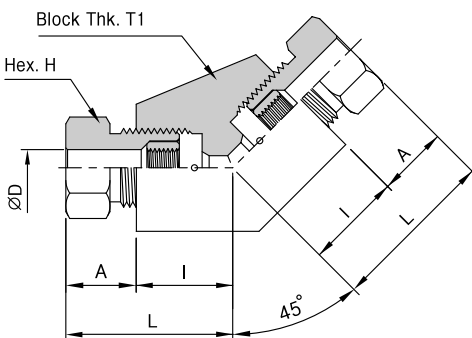

## 45° Elbows

Unit : mm

Catalog No.	Pressure Rating psig	Tube Size	D	A	I	L	H	T <sub>1</sub>
HPLB60K-2H	60,000	1/8"	3.2	10.5	19.1	29.6	12.7	19.1
HPLB60K-4H	60,000	1/4"	6.4	12.7	15.7	28.4	15.9	19.1
HPLB60K-6H	60,000	3/8"	9.5	13.5	25.4	38.9	20.6	25.4
HPLB60K-9H	60,000	9/16"	14.3	20.5	28.4	48.9	30.2	38.0

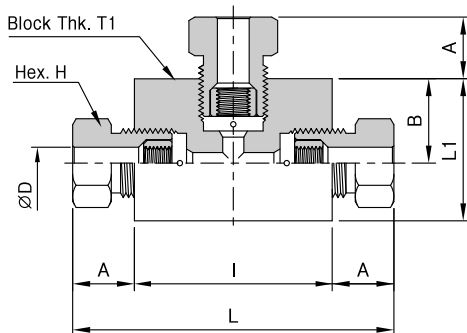

## Tees

Unit : mm

Catalog No.	Pressure Rating psig	Tube Size	D	A	B	I	L <sub>1</sub>	L	H	T <sub>1</sub>
HPT60K-2H	60,000	1/8"	3.2	10.5	19.1	38.1	28.6	59.1	12.7	19.1
HPT60K-4H	60,000	1/4"	6.4	12.7	22.4	50.8	31.8	76.2	15.9	19.1
HPT60K-6H	60,000	3/8"	9.5	13.5	26.9	50.8	39.6	77.8	20.6	25.4
HPT60K-9H	60,000	9/16"	14.3	20.5	35.1	66.5	53.8	107.5	30.2	38.0

ALL DIMENSIONS ARE FOR REFERENCE ONLY, SUBJECT TO CHANGE.

# High Pressure Fittings Pressure to 60,000psig

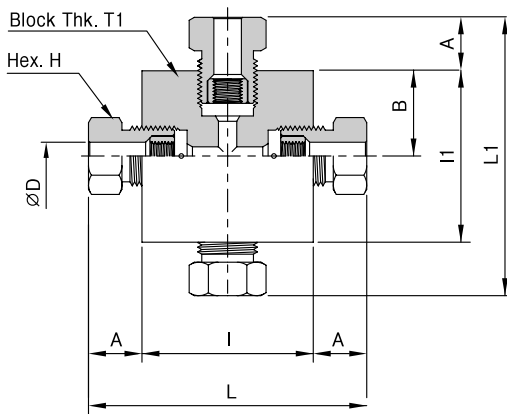

## Crosses

Catalog No.	Pressure Rating psig	Tube Size	D	A	B	I	I <sub>1</sub>	L	L <sub>1</sub>	H	T <sub>1</sub>
HPX60K-2H	60,000	1/8"	3.2	10.5	19.1	38.1	38.1	59.1	59.1	12.7	19.1
HPX60K-4H	60,000	1/4"	6.4	12.7	15.7	50.8	31.8	76.2	57.2	15.9	19.1
HPX60K-6H	60,000	3/8"	9.5	13.5	26.9	50.8	53.8	77.8	80.8	20.6	25.4
HPX60K-9H	60,000	9/16"	14.3	20.5	35.1	66.5	70.0	107.5	111.1	30.2	38.0

m

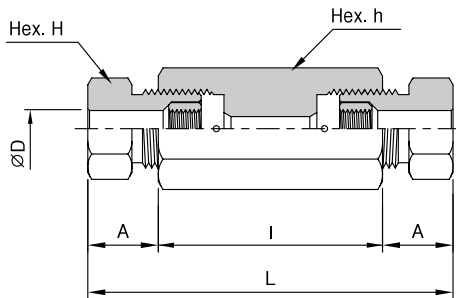

## Straight Couplings

Unit : mm

Catalog No.	Pressure Rating psig	Tube Size	D	A	I	L	h	H
HPF60K-2H	60,000	1/8"	3.2	10.5	28.6	49.6	19.1	12.7
HPF60K-4H	60,000	1/4"	6.4	12.7	35.1	60.5	19.1	15.9
HPF60K-6H	60,000	3/8"	9.5	13.5	44.5	71.5	25.4	20.6
HPF60K-9H	60,000	9/16"	14.3	20.5	55.5	96.5	35.0	30.2

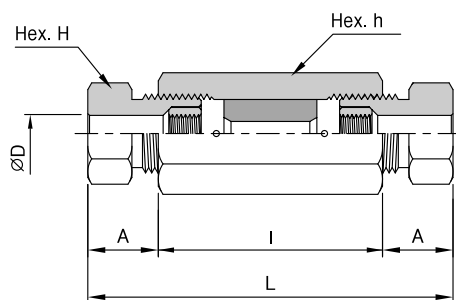

## Union Couplings(Slip Type)

Unit : mm

Catalog No.	Pressure Rating psig	Tube Size	D	A	I	L	h	H
HPUF60K-2H	60,000	1/8"	3.2	10.5	28.6	49.6	19.1	12.7
HPUF60K-4H	60,000	1/4"	6.4	12.7	35.1	60.5	19.1	15.9
HPUF60K-6H	60,000	3/8"	9.5	13.5	44.5	71.5	25.4	20.6
HPUF60K-9H	60,000	9/16"	14.3	20.5	55.5	96.5	35.0	30.2

ALL DIMENSIONS ARE FOR REFERENCE ONLY, SUBJECT TO CHANGE.

## Reducing Couplings \*

Unit : mm

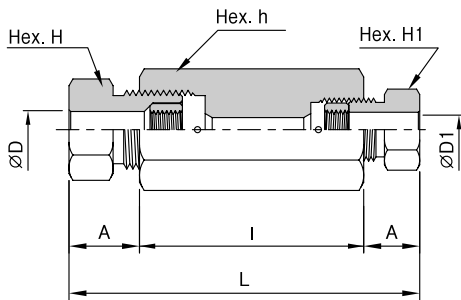

Catalog No.	Pressure Rating psig	Connections	D	D <sub>1</sub>	A	B	I	L	h	H	H <sub>1</sub>
HPRU20K-4H-4M	20,000	1/4"H/Px1/4"M/P	6.4	6.4	10.5	9.7	38.1	58.3	19.1	15.9	12.7
HPRU20K-4H-6M	20,000	1/4"H/Px3/8"M/P	6.4	9.5	10.5	11.9	44.5	66.9	19.1	15.9	12.7
HPRU20K-4H-9M	20,000	1/4"H/Px9/16"M/P	6.4	14.3	10.5	13.5	50.8	74.8	25.4	15.9	22.4
HPRU20K-4H-12M	20,000	1/4"H/Px3/4"M/P	6.4	19.1	10.5	15.7	63.5	89.7	35.0	15.9	28.4
HPRU20K-6H-4M	20,000	3/8"H/Px3/8"M/P	9.5	6.4	12.7	9.7	44.5	66.9	25.4	20.6	12.7
HPRU20K-6H-6M	20,000	3/8"H/Px3/8"M/P	9.5	9.5	12.7	11.9	50.8	75.4	25.4	20.6	15.7
HPRU20K-6H-9M	20,000	3/8"H/Px9/16"M/P	9.5	14.3	12.7	13.5	50.8	77.0	25.4	20.6	22.4
HPRU20K-6H-12M	20,000	3/8"H/Px3/4"M/P	9.5	19.1	12.7	15.7	63.5	91.9	35.0	20.6	28.7
HPRU20K-9H-4M	20,000	9/16"H/Px1/4"M/P	14.3	6.4	13.5	9.7	57.2	80.4	35.0	30.2	12.7
HPRU20K-9H-6M	20,000	9/16"H/Px3/8"M/P	14.3	9.5	13.5	11.9	57.2	82.6	35.0	30.2	15.7
HPRU20K-9H-9M	20,000	9/16"H/Px9/16"M/P	14.3	14.3	13.5	13.5	57.2	84.2	35.0	30.2	22.4
HPRU20K-9H-12M	20,000	9/16"H/Px3/4"M/P	14.3	19.1	13.5	15.7	63.5	92.7	35.0	30.2	28.7

\*: Pressure rating shown is the lower out of two different pressures.

## Male Connectors \* (H/P Tube to Pipe)

Unit : mm

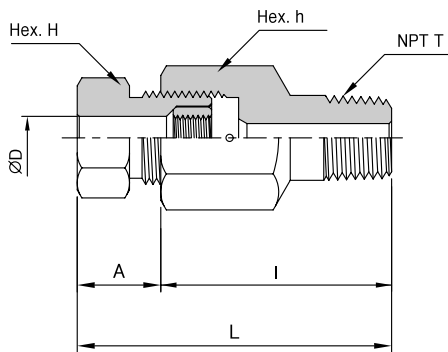

Catalog No.	Pressure Rating psig	Connections	D	T NPT	A	h	H	I	L
HPMC10K-2H-2N	10,000	1/8" H/P x 1/8" NPT	3.2	1/8"	10.5	12.7	12.7	21.3	31.8
HPMC10K-2H-4N	10,000	1/8" H/P x 1/4" NPT	3.2	1/4"	10.5	15.9	12.7	21.3	31.8
HPMC10K-4H-4N	10,000	1/4" H/P x 1/4" NPT	6.4	1/4"	12.7	19.1	15.9	22.2	34.9
HPMC10K-4H-6N	10,000	1/4" H/P x 3/8" NPT	6.4	3/8"	12.7	19.1	15.9	22.2	34.9
HPMC10K-6H-6N	10,000	3/8" H/P x 3/8" NPT	9.5	3/8"	13.5	25.4	20.6	27.8	41.3
HPMC10K-6H-8N	10,000	3/8" H/P x 1/2" NPT	9.5	1/2"	13.5	25.4	20.6	31.0	44.5
HPMC10K-9H-8N	10,000	9/16" H/P x 1/2" NPT	14.3	1/2"	20.5	35.0	30.2	53.8	74.3
HPMC10K-9H-12N	10,000	9/16" H/P x 3/4" NPT	14.3	3/4"	20.5	35.0	30.2	53.8	74.3

\*: Pressure rating shown is according to pipe thread.

## Female Connectors \* (H/P Tube to Pipe)

Unit : mm

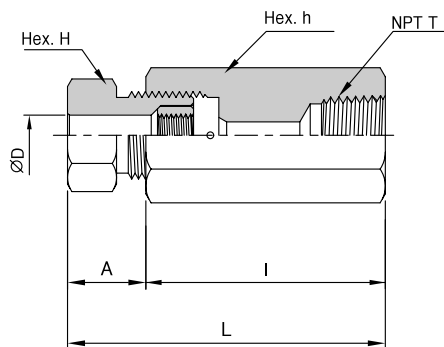

Catalog No.	Pressure Rating psig	Connections	D	T NPT	A	h	H	I	L
HPFC10K-2H-2N	10,000	1/8" H/P x 1/8" NPT	3.2	1/8"	10.5	19.1	12.7	26.2	38.9
HPFC10K-2H-4N	10,000	1/8" H/P x 1/4" NPT	3.2	1/4"	10.5	19.1	12.7	31.0	43.7
HPFC10K-4H-4N	10,000	1/4" H/P x 1/4" NPT	6.4	1/4"	12.7	19.1	15.9	38.1	50.8
HPFC10K-4H-6N	10,000	1/4" H/P x 3/8" NPT	6.4	3/8"	12.7	25.4	15.9	41.1	53.8
HPFC10K-6H-6N	10,000	3/8" H/P x 3/8" NPT	9.5	3/8"	13.5	25.4	20.6	44.5	58.0
HPFC10K-6H-8N	10,000	3/8" H/P x 1/2" NPT	9.5	1/2"	13.5	31.8	20.6	59.8	67.3
HPFC10K-9H-8N	10,000	9/16" H/P x 1/2" NPT	14.3	1/2"	20.5	35.0	30.2	57.2	77.7
HPFC10K-9H-12N	10,000	9/16" H/P x 3/4" NPT	14.3	3/4"	20.5	44.5	30.2	63.5	84.0

\*: Pressure rating shown is according to pipe thread.

ALL DIMENSIONS ARE FOR REFERENCE ONLY, SUBJECT TO CHANGE.

## Sour Gas Service Fittings Pressure to 30,000psig

Hy-Lok High pressure Fittings are designed to resist in sour environment and rated for a maximum working pressure of 30,000psig at 100°F.

Materials for wetted parts are selected in accordance with NACE MR-0175 for sulfide stress cracking resistant materials.

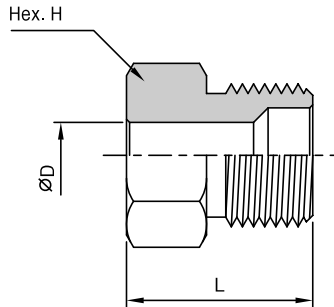

### Glands

Unit : mm

Catalog No.	Pressure Rating psig	Tube Size	D	L	H
HPG30K-2H-SOG	30,000	1/8"	3.2	19.1	12.7
HPG30K-4H-SOG	30,000	1/4"	6.4	22.6	15.9
HPG30K-6H-SOG	30,000	3/8"	9.5	30.1	20.6
HPG30K-9H-SOG	30,000	9/16"	14.3	38.1	30.2

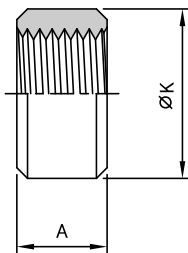

### Collars

Unit : mm

Catalog No.	Pressure Rating psig	Tube Size	A	K
HPC30K-2H-SOG	30,000	1/8"	7.9	6.4
HPC30K-4H-SOG	30,000	1/4"	9.5	9.5
HPC30K-6H-SOG	30,000	3/8"	12.7	12.7
HPC30K-9H-SOG	30,000	9/16"	15.7	20.6

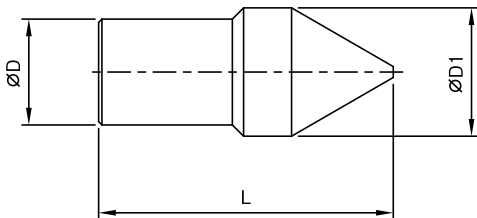

### Plugs

Unit : mm

Catalog No.	Pressure Rating psig	Tube Size	D	L	D <sub>1</sub>
HPP30K-2H-SOG	30,000	1/8"	3.2	22.2	6.4
HPP30K-4H-SOG	30,000	1/4"	6.4	29.2	9.7
HPP30K-6H-SOG	30,000	3/8"	9.5	39.6	12.7
HPP30K-9H-SOG	30,000	9/16"	14.3	51.0	20.5

ALL DIMENSIONS ARE FOR REFERENCE ONLY, SUBJECT TO CHANGE.

# Sour Gas Service Fittings Pressure to 30,000psig

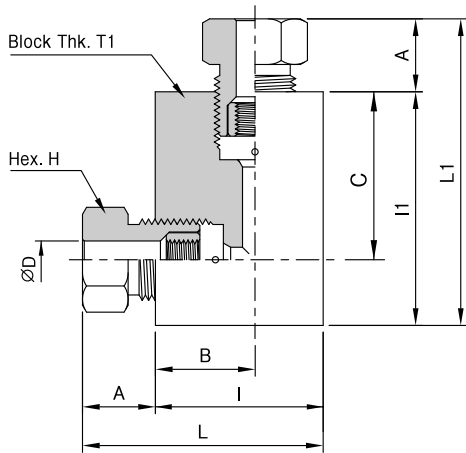

## Elbows

Unit : mm

Catalog No.	Pressure Rating psig	Tube Size	D	A	B	C	I	I <sub>1</sub>	L	L <sub>1</sub>	H	T <sub>1</sub>
HPL30K-2H-SOG	30,000	1/8"	3.2	10.5	19.1	19.1	28.6	28.6	39.1	39.1	12.7	19.1
HPL30K-4H-SOG	30,000	1/4"	6.4	12.7	15.7	22.4	25.4	38.1	38.1	50.1	15.9	19.1
HPL30K-6H-SOG	30,000	3/8"	9.5	13.5	25.4	31.8	38.1	50.1	51.6	63.6	20.6	25.4
HPL30K-9H-SOG	30,000	9/16"	14.3	20.5	28.4	47.8	47.8	66.5	68.3	87.0	30.2	38.0

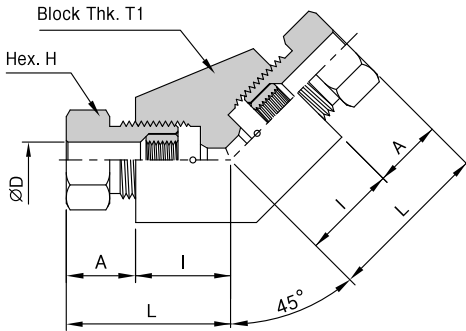

## 45° Elbows

Unit : mm

Catalog No.	Pressure Rating psig	Tube Size	D	A	I	L	H	T <sub>1</sub>
HPLB30K-2H-SOG	30,000	1/8"	3.2	10.5	19.1	29.6	12.7	19.1
HPLB30K-4H-SOG	30,000	1/4"	6.4	12.7	15.7	28.4	15.9	19.1
HPLB30K-6H-SOG	30,000	3/8"	9.5	13.5	25.4	38.9	20.6	25.4
HPLB30K-9H-SOG	30,000	9/16"	14.3	20.5	28.4	48.9	30.2	38.0

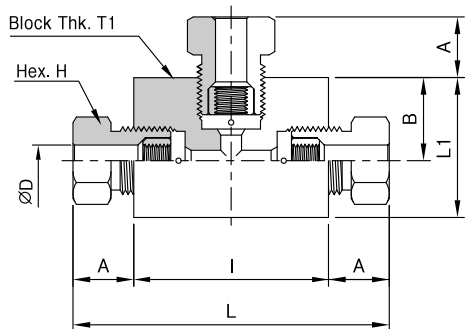

## Tees

Unit : mm

Catalog No.	Pressure Rating psig	Tube Size	D	A	B	I	L <sub>1</sub>	L	H	T <sub>1</sub>
HPT30K-2H-SOG	30,000	1/8"	3.2	10.5	19.1	38.1	28.6	59.1	12.7	19.1
HPT30K-4H-SOG	30,000	1/4"	6.4	12.7	22.4	50.8	31.8	76.2	15.9	19.1
HPT30K-6H-SOG	30,000	3/8"	9.5	13.5	26.9	50.8	39.6	77.8	20.6	25.4
HPT30K-9H-SOG	30,000	9/16"	14.3	20.5	35.1	66.5	53.8	107.5	30.2	38.0

ALL DIMENSIONS ARE FOR REFERENCE ONLY, SUBJECT TO CHANGE.

# Sour Gas Service Fittings Pressure to 30,000psig

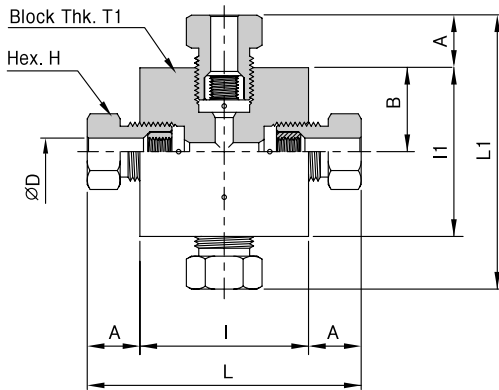

## Crosses

Unit : mm

Catalog No.	Pressure Rating psig	Tube Size	D	A	B	I	I <sub>1</sub>	L	L <sub>1</sub>	H	T <sub>1</sub>
HPX30K-2H-SOG	30,000	1/8"	3.2	10.5	19.1	38.1	38.1	59.1	59.1	12.7	19.1
HPX30K-4H-SOG	30,000	1/4"	6.4	12.7	15.7	50.8	31.8	76.2	57.2	15.9	19.1
HPX30K-6H-SOG	30,000	3/8"	9.5	13.5	26.9	50.8	53.8	77.8	80.8	20.6	25.4
HPX30K-9H-SOG	30,000	9/16"	14.3	20.5	35.1	66.5	70.0	107.5	111.1	30.2	38.0

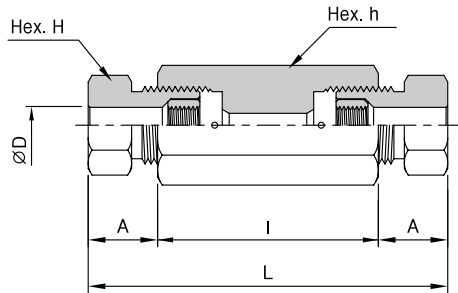

## Straight Couplings

Unit : mm

Catalog No.	Pressure Rating psig	Tube Size	D	A	I	L	h	H
HPF30K-2H-SOG	30,000	1/8"	3.2	10.5	28.6	49.6	19.1	12.7
HPF30K-4H-SOG	30,000	1/4"	6.4	12.7	35.1	60.5	19.1	15.9
HPF30K-6H-SOG	30,000	3/8"	9.5	13.5	44.5	71.5	25.4	20.6
HPF30K-9H-SOG	30,000	9/16"	14.3	20.5	55.5	96.5	35.0	30.2

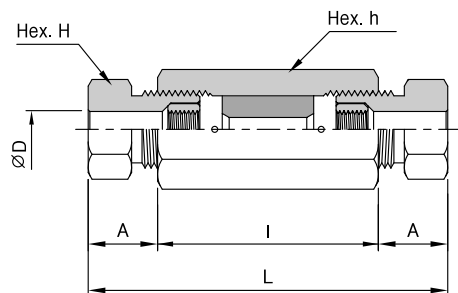

## Union Couplings(Slip Type)

Unit : mm

Catalog No.	Pressure Rating psig	Tube Size	D	A	I	L	h	H
HPUF30K-2H-SOG	30,000	1/8"	3.2	10.5	28.6	49.6	19.1	12.7
HPUF30K-4H-SOG	30,000	1/4"	6.4	12.7	35.1	60.5	19.1	15.9
HPUF30K-6H-SOG	30,000	3/8"	9.5	13.5	44.5	71.5	25.4	20.6
HPUF30K-9H-SOG	30,000	9/16"	14.3	20.5	55.5	96.5	35.0	30.2

ALL DIMENSIONS ARE FOR REFERENCE ONLY, SUBJECT TO CHANGE.



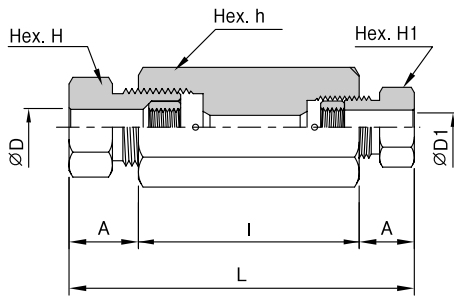

## Reducing Couplings \*

Unit : mm

Catalog No.	Pressure Rating psig	Connections	D	D <sub>1</sub>	A	B	I	L	h	H	H <sub>1</sub>
HPRU10K-4H-4M-SOG	10,000	1/4"H/Px1/4"M/P	6.4	6.4	10.5	9.7	38.1	58.3	19.1	15.9	12.7
HPRU10K-4H-6M-SOG	10,000	1/4"H/Px3/8"M/P	6.4	9.5	10.5	11.9	44.5	66.9	19.1	15.9	12.7
HPRU10K-4H-9M-SOG	10,000	1/4"H/Px9/16"M/P	6.4	14.3	10.5	13.5	50.8	74.8	25.4	15.9	22.4
HPRU10K-4H-12M-SOG	10,000	1/4"H/Px3/4"M/P	6.4	19.1	10.5	15.7	63.5	89.7	35.0	15.9	28.4
HPRU10K-6H-4M-SOG	10,000	3/8"H/Px1/4"M/P	9.5	6.4	12.7	9.7	44.5	66.9	25.4	20.6	12.7
HPRU10K-6H-6M-SOG	10,000	3/8"H/Px3/8"M/P	9.5	9.5	12.7	11.9	50.8	75.4	25.4	20.6	15.7
HPRU10K-6H-9M-SOG	10,000	3/8"H/Px9/16"M/P	9.5	14.3	12.7	13.5	50.8	77.0	25.4	20.6	22.4
HPRU10K-6H-12M-SOG	10,000	3/8"H/Px3/4"M/P	9.5	19.1	12.7	15.7	63.5	91.9	35.0	20.6	28.7
HPRU10K-9H-4M-SOG	10,000	9/16"H/Px1/4"M/P	14.3	6.4	13.5	9.7	57.2	80.4	35.0	30.2	12.7
HPRU10K-9H-6M-SOG	10,000	9/16"H/Px3/8"M/P	14.3	9.5	13.5	11.9	57.2	82.6	35.0	30.2	15.7
HPRU10K-9H-9M-SOG	10,000	9/16"H/Px9/16"M/P	14.3	14.3	13.5	13.5	57.2	84.2	35.0	30.2	22.4
HPRU10K-9H-12M-SOG	10,000	9/16"H/Px3/4"M/P	14.3	19.1	13.5	15.7	63.5	92.7	35.0	30.2	28.7

\*" Pressure rating shown is the lower out of two different pressures.

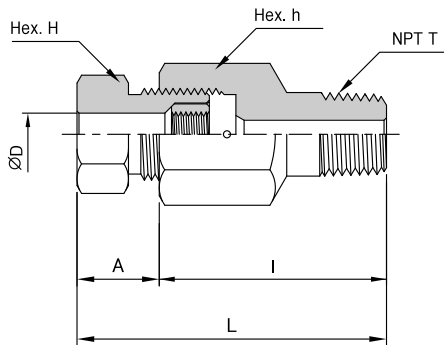

## Male Connectors (H/P Tube to Pipe) \*

Unit : mm

Catalog No.	Pressure Rating psig	Connections	D	T NPT	A	h	H	I	L
HPMC10K-2H-2N-SOG	10,000	1/8" H/P x 1/8" NPT	3.2	1/8"	10.5	12.7	12.7	21.3	31.8
HPMC10K-2H-4N-SOG	10,000	1/8" H/P x 1/4" NPT	3.2	1/4"	10.5	15.9	12.7	21.3	31.8
HPMC10K-4H-4N-SOG	10,000	1/4" H/P x 1/4" NPT	6.4	1/4"	12.7	19.1	15.9	22.2	34.9
HPMC10K-4H-8N-SOG	10,000	1/4" H/P x 3/8" NPT	6.4	3/8"	12.7	19.1	15.9	22.2	34.9
HPMC10K-6H-8N-SOG	10,000	3/8" H/P x 3/8" NPT	9.5	3/8"	13.5	25.4	20.6	27.8	41.3
HPMC10K-6H-8N-SOG	10,000	3/8" H/P x 1/2" NPT	9.5	1/2"	13.5	25.4	20.6	31.0	44.5
HPMC10K-9H-8N-SOG	10,000	9/16" H/P x 1/2" NPT	14.3	1/2"	20.5	35.0	30.2	53.8	74.3
HPMC10K-9H-12N-SOG	10,000	9/16" H/P x 3/4" NPT	14.3	3/4"	20.5	35.0	30.2	53.8	74.3

\*" Pressure rating shown is according to pipe thread.

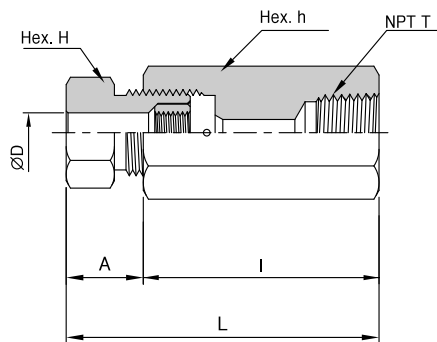

## Female Connectors (H/P Tube to Pipe) \*

Unit : mm

Catalog No.	Pressure Rating psig	Connections	D	T NPT	A	h	H	I	L
HPFC10K-2H-2N-SOG	10,000	1/8" H/P x 1/8" NPT	3.2	1/8"	10.5	19.1	12.7	26.2	38.9
HPFC10K-2H-4N-SOG	10,000	1/8" H/P x 1/4" NPT	3.2	1/4"	10.5	19.1	12.7	31.0	43.7
HPFC10K-4H-4N-SOG	10,000	1/4" H/P x 1/4" NPT	6.4	1/4"	12.7	19.1	15.9	38.1	50.8
HPFC10K-4H-6N-SOG	10,000	1/4" H/P x 3/8" NPT	6.4	3/8"	12.7	25.4	15.9	41.1	53.8
HPFC10K-6H-6N-SOG	10,000	3/8" H/P x 3/8" NPT	9.5	3/8"	13.5	25.4	20.6	44.5	58.0
HPFC10K-6H-8N-SOG	10,000	3/8" H/P x 1/2" NPT	9.5	1/2"	13.5	31.8	20.6	59.8	67.3
HPFC10K-9H-8N-SOG	10,000	9/16" H/P x 1/2" NPT	14.3	1/2"	20.5	35.0	30.2	57.2	77.7
HPFC10K-9H-12N-SOG	10,000	9/16" H/P x 3/4" NPT	14.3	3/4"	20.5	44.5	30.2	63.5	84.0

\*" Pressure rating shown is according to pipe thread.

ALL DIMENSIONS ARE FOR REFERENCE ONLY, SUBJECT TO CHANGE.

## Nipples

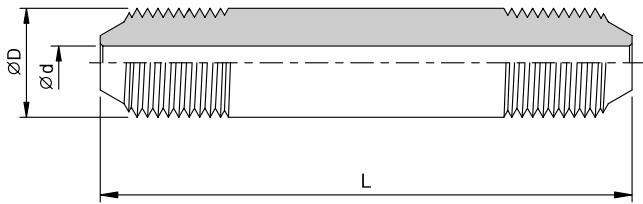

### Special Lengths

In addition to the standard lengths cataloged in the table below, nipples are available in any custom length. Consult factory.

### Materials

Catalog numbers in table refer to Type 316 stainless steel. Type 304 stainless steel nipples available. Consult factory.

## Pressure to 60,000psig

Catalog No.							O.D(D)	I.D(d)	Working Pressure at 100°F psig
2.75" Length(L)	3" Length(L)	4" Length(L)	6" Length(L)	8" Length(L)	10" Length(L)	12" Length(L)			
HPNP60K-4H02L	HPNP60K-4H03L	HPNP60K-4H04L	HPNP60K-4H06L	HPNP60K-4H08L	HPNP60K-4H10L	HPNP60K-4H12L	1/4"	0.083"	60,000
	HPNP60K-6H03L	HPNP60K-6H04L	HPNP60K-6H06L	HPNP60K-6H08L	HPNP60K-6H10L	HPNP60K-6H12L	3/8"	0.125"	60,000
		HPNP60K-9H04L	HPNP60K-9H06L	HPNP60K-9H08L	HPNP60K-9H10L	HPNP60K-9H12L	9/16"	0.187"	60,000

## Pressure to 30,000psig for Sour Gas Service Fittings

Catalog No.							O.D(D)	I.D(d)	Working Pressure at 100°F psig
2.75" Length(L)	3" Length(L)	4" Length(L)	6" Length(L)	8" Length(L)	10" Length(L)	12" Length(L)			
HPNP30K-4H02L-SOG	HPNP30K-4H03L-SOG	HPNP30K-4H04L-SOG	HPNP30K-4H06L-SOG	HPNP30K-4H08L-SOG	HPNP30K-4H10L-SOG	HPNP30K-4H12L-SOG	1/4"	0.083"	30,000
	HPNP30K-6H03L-SOG	HPNP30K-6H04L-SOG	HPNP30K-6H06L-SOG	HPNP30K-6H08L-SOG	HPNP30K-6H10L-SOG	HPNP30K-6H12L-SOG	3/8"	0.125"	30,000
		HPNP30K-9H04L-SOG	HPNP30K-9H06L-SOG	HPNP30K-9H08L-SOG	HPNP30K-9H10L-SOG	HPNP30K-9H12L-SOG	9/16"	0.187"	30,000

ALL DIMENSIONS ARE FOR REFERENCE ONLY, SUBJECT TO CHANGE.

## Installation Instruction

### ■ General

The High Pressure (coned and threaded) tubing connection is available for 1/8, 1/4, and 9/16 inches OD tubing sizes. All sizes are available for up to 60,000 psig working pressure. The tubing may be prepared with the use of tooling or prepared at the factory to specified lengths. Additionally, standard length coned and threaded tubing nipples are available from stock.

This connection has become an industry standard for use at elevated pressures and temperatures in both liquid and gas applications. It may be disassembled and then retightened indefinitely.

The threads of the gland are right-hand while the threads of the collar and tubing are left-hand to prevent rotation of the collar during assembly.

Materials. Both the gland and the collar are made from Type 17-4 PH stainless steel, with both available in Type 316 stainless steel as an option. Plugs are Type 316 stainless steel.

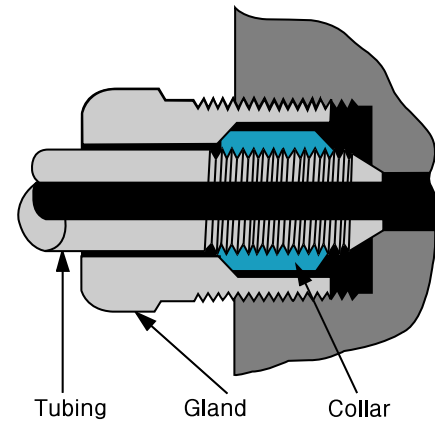

### ■ What's the Difference?

Both the "Medium Pressure" and "High Pressure" connections are coned and threaded tubing designs. The "Medium Pressure" connection provides large bore sizes for use up to 20,000psig working pressure. The "High Pressure" connection has smaller bore sizes for use up to 60,000psig working pressure. Note that these connections are not interchangeable with each other but adapters are available.

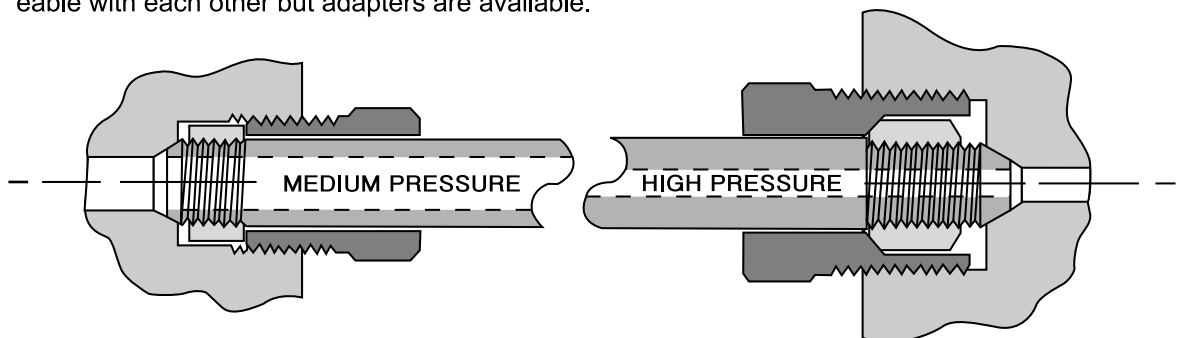

ALL DIMENSIONS ARE FOR REFERENCE ONLY, SUBJECT TO CHANGE.

# Installation Instruction

## ■ Coning and Threading of Tubing

1. Cut tubing to length and deburr. Allow extra length for proper engagement within connection per first table below.

Pressure Series	Tube Size	Extra Allowance For Engagement	
		Inches	(mm)
"M" Series (20,000psi)	1/4"	0.55	(14.0)
	3/8"	0.69	(17.5)
	9/16"	0.84	(21.3)
	3/4"	1.00	(25.4)
	1"	1.44	(36.6)
"H" Series (60,000psig)	1/4"	0.50	(12.7)
	3/8"	0.69	(17.5)
	9/16"	0.84	(21.3)

- \* Apply pressure to start cutting action and rotate die holder counter-clockwise until threads of the following lengths have been cut.

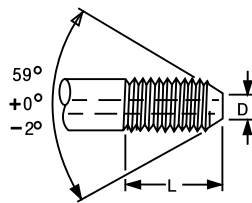

2. Coning



3. Threading

## ■ Assembly and Makeup of Connection

1. Lubricate male threads of gland. Slip gland on tubing as shown and thread collar on tubing until one to two threads are exposed between collar and cone.
2. Lubricate male threads of gland with a metal particle impregnated lubricant. Insert tubing in connection, engage gland and tighten "fingertight".
3. Tighten gland slightly with the wrench

Pressure Series	Tube Size O.D x I.D Inches (mm)	Dimensions Inches (mm)		Thread Size Inches (mm)	
		D	L(max)		
Medium Pressure "M" Series (20,000psig)	1/4 x 0.109 (6.35) x (2.77)	0.141 (3.58)	0.344 (8.74)	1/4 -28 (6.35) -28	
	3/8 x 0.203 (9.53) x (5.16)	0.250 (6.35)	0.438 (11.1)	3/8 -24 (9.53) -24	
	9/16 x 0.312 (14.3) x (7.92)	0.406 (10.3)	0.500 (12.70)	9/16 -18 (14.3) -18	
	9/16 x 0.359 (14.3) x (9.12)	0.438 (11.1)	0.500 (12.7)	9/16 -18 (14.3) -18	
	3/4 x 0.438 (19.1) x (11.1)	0.562 (14.3)	0.625 (15.9)	3/4 -16 (19.1) -16	
	3/4 x 0.516 (19.1) x (13.1)	0.578 (14.7)	0.625 (15.9)	3/4 -16 (19.1) -16	
	1 x 0.562 (25.4) x (14.3)	0.719 (18.3)	0.781 (19.8)	1 -14 (25.4) -14	
	1 x 0.688 (25.4) x (17.5)	0.812 (20.6)	0.781 (19.8)	1 -14 (25.4) -14	
	High Pressure "H" Series (60,000psig)	1/4 x 0.083 (6.35) x (2.11)	0.125 (3.18)	0.562 (14.3)	1/4 -28 (6.35) -28
		3/8 x 0.125 (9.53) x (3.18)	0.219 (5.56)	0.750 (19.1)	3/8 -24 (9.53) -24
		9/16 x 0.188 (14.3) x (4.78)	0.281 (7.14)	0.938 (23.8)	9/16 -18 (14.3) -18

\* Thread is left-hand national fine.



Step 1, 2

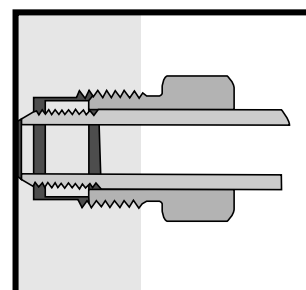

"M" Series Connection

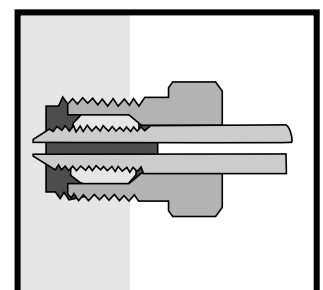

"H" Series Connection

Step 3

ALL DIMENSIONS ARE FOR REFERENCE ONLY, SUBJECT TO CHANGE.



### ■ Coning Tool

- \* Three simple steps, and you have a perfect cone in less than one minute.
- \* No collets or feed nuts to tighten or loosen. NO presetting required. No experience necessary.
- \* No deburring necessary on O.D. of tube.
- \* More coned ends per day. No fatigue on operators, with less cost per hook-up
- \* Tool can be removed anytime during coning operation for quick visual inspections
- \* This Coning Tools are less expensive than other hand operated designs and will give more cones and faster hook-ups. Cutters cut angle and face end of tubing for squareness.
- \* A 3/8" or 1/2" drill motor will be required.



### ■ Threading Tool

- \* New improved designs for cutting a perfect thread.
- \* Two models are offered; a motor driven design for fast cutting of many tubes, and the hand design for threading small quantities of tubing
- \* All threads for pressure tubing are Left Hand National Fine



### ■ Tube Vise

The tube vise is another unique tool manufactured by Hy-Lok Pressure Systems; again, with the operator and technician in mind. Advantages include:

- \* Lightweight and inexpensive
- \* No collapsing tubing
- \* Better holding power on tubes
- \* No soft jaws required on vises
- \* No marking the O.D of the tubing
- \* Use as a stop gauge when coning and threading

ALL DIMENSIONS ARE FOR REFERENCE ONLY, SUBJECT TO CHANGE.

# Ordering Instruction

## ■ Catalog Numbering System

HP	L	60K	-9H	-12M	-SOG	-S316
Type of Fittings	Type of Components	Pressure Series	Connections Size & Grade		Option	Material
	G : Gland C : Collar NP : Nipple F : Straight Coupling UF : Union Coupling RU : Reducing Coupling L : 90° Elbow LB : 45° Elbow T : Tee X : Cross MC : Male Connector FC : Female Connector MA : Male Adapter	10K=10,000 psi 20K=20,000 psi 30K=30,000 psi 60K=60,000 psi	2 : 1/8" Tube 4 : 1/4" Tube 6 : 3/8" Tube 9 : 9/16" Tube 12 : 3/4" Tube 16 : 1" Tube 2N : 1/8" NPT 4N : 1/4" NPT 6N : 3/8" NPT 8N : 1/2" NPT 12N : 3/4" NPT 16N : 1" NPT M : Medium H : High	If different from first connection	SOG : Sour Oil & Gas Service	S316 : Stainless steel 316

ALL DIMENSIONS ARE FOR REFERENCE ONLY, SUBJECT TO CHANGE.

## ■ How to order

Simply indicate catalog number and specify option

### Example :

30,000psig 90° Elbow for 9/16" O.D Tubing,  
 Made from Stainless steel Grade-316 with NACE-MR-01-75  
 Part Number : AF





DANMARK  
Metalgangen 13  
DK-2690 Karlslunde  
Danmark  
+(45) 73 84 12 30  
info@pgflowteknik.dk  
www.pgflowteknik.dk

SVERIGE  
www.pgflowteknik.se  
+(46) 70 684 1230

The logo for Indutrade features a stylized 'I' symbol composed of three vertical bars of varying heights, followed by the word 'Indutrade' in a bold, white, sans-serif font.

**Indutrade**

PG FLOWTEKNIK SCANDINAVIA - EN DEL AF INDUTRADE