

# FT Series Micron inline filter

**Hy-Lok**

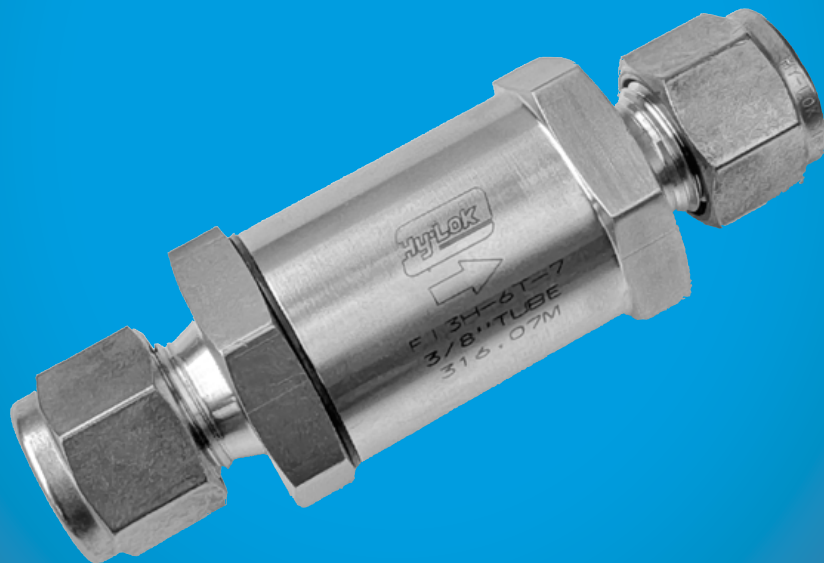

**FLOWTEKNIK**  
SCANDINAVIA APS



# FT Series Micron Inline filters

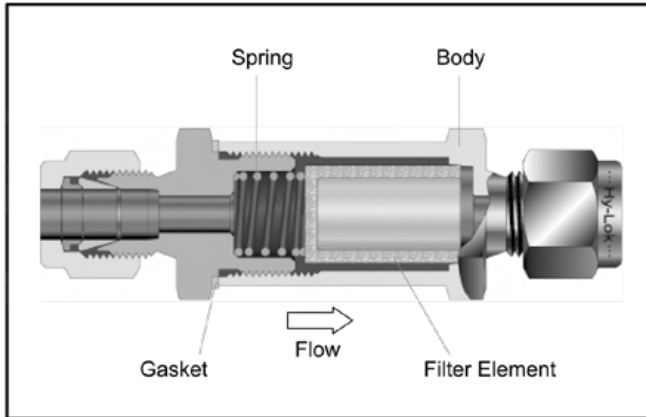

## Features

- In-line filters are for use where space is limited
- Replaceable Filter element
- Particle trapping for clean fluid

## Material of Construction

Description	Material / ASTM Specification	
Body	SS316 / A479	BRASS / B16
Spring	SS302	
Gasket	Silver-plated SS316 / A240	Aluminum / B209
Filter Elements	SS316 Sintered	

## Flow Data at 70°F (20°C)

Nominal Element Pore Size $\mu\text{m}$	Inlet Pressure, psig (bar)			Pressure Drop, psig (bar)		
	5 (0.34)	10 (0.68)	15 (1.0)	10 (0.68)	50 (3.4)	100 (6.8)
	Air Flow, std in /min (std L/min)			Water Flow, std in /min (std L/min)		
0.5	67.13 (1.1)	103.76 (1.7)	207.49 (3.4)	1.83 (0.03)	9.15 (0.15)	27.46 (0.45)
2	341.75 (5.6)	671.30 (11)	1037.46 (17)	18.30 (0.30)	55.53 (0.91)	91.54 (1.5)
7	854.38 (14)	1525.68 (25)	2074.92 (34)	22.58 (0.37)	67.13 (1.1)	109.85 (1.8)
15	1342.59 (22)	2196.97 (36)	2563.13 (42)	27.46 (0.45)	79.34 (1.3)	128.16 (2.1)
60	2929.30 (48)	3783.67 (62)	4149.84 (68)	34.18 (0.56)	109.85 (1.8)	158.67 (2.6)
90	3112.38 (51)	3783.67 (62)	4454.97 (73)	45.77 (0.75)	109.85 (1.8)	134.26 (2.2)

## Technical Data

• **Maximum Operating Pressure** : 3000 PSI @ 70°F (21°C)

• **Operating Temperature Range** :

From -20°F to 900°F (-28°C to 482°C) with SS316 body.  
and up to 300°F (148°C) with Brass body

• **Effective Filtration Area** :

Series	Effective Filtration Area
FI1	0.55 sq. in. (0.00035 sq. meter)
FI2	1.30 sq. in. (0.00083 sq. meter)
FI3, FI4	2.0 sq. in. (0.00128 sq. meter)

• **Filter elements**

Elements remove 95% of particles larger than the nominal pore size.

Nominal pore Size $\mu\text{m}$	Pore Size Range $\mu\text{m}$
0.5	0.5 to 2
2	1 to 4
7	5 to 10
15	11 to 25
60	50 to 75
90	75 to 100

## Operation and Filter Replacement

The filter element, which is made of sintered stainless steel, is porous and has lots of tiny holes. Particles bigger than the pores are not allowed to pass through, hence clean system media. After a certain period, the holes may be blocked by particles and pressure drop will increase. This depends upon the total flow through the elements and cleanliness of upstream flow. The element needs to be replaced for clean system media with minimal pressure drop.

# FT Series Micron Inline filters

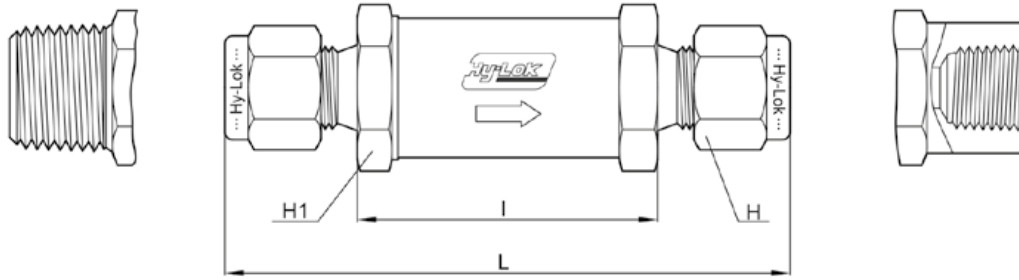

## Table of Dimensions

Basic Part No.			Orifice in.(mm)	End Connection		Dimensions, in.(mm)			
Series	Part No.			Inlet	Outlet	L	I	H	H <sub>1</sub>
FI 1	H	- 2T -	0.094 (2.4)	1/8 Hy-Lok	1/8 Hy-Lok	2.35 (59.7)	1.15 (29.2)	7/16 (11.1)	9/16 (14.3)
	M	- 2N -		1/8 Male NPT	1/8 Male NPT	1.91 (48.6)		-	
	F	- 2N -		1/8 Female NPT	1/8 Female NPT	2.16 (54.9)		-	
	H	- 3M -		3mm Hy-Lok	3mm Hy-Lok	2.38 (60.5)		0.47 (12.0)	
FI 2	H	- 4T -	0.187 (4.8)	1/4 Hy-Lok	1/4 Hy-Lok	2.96 (75.2)	1.56 (39.7)	9/16 (14.3)	3/4 (19.0)
	M	- 4N -		1/4 Male NPT	1/4 Male NPT	2.69 (68.3)		-	
	F	- 4N -		1/4 Female NPT	1/4 Female NPT	2.87 (72.9)		-	
	H	- 6M -		6mm Hy-Lok	6mm Hy-Lok	2.96 (75.2)		0.55 (14.0)	
FI 3	H	- 6T -	0.281 (7.1)	3/8 Hy-Lok	3/8 Hy-Lok	3.22 (81.8)	1.70 (43.2)	11/16 (17.4)	1 (25.4)
	M	- 6N -		3/8 Male NPT	3/8 Male NPT	2.82 (71.6)		-	
	F	- 6N -		3/8 Female NPT	3/8 Female NPT	3.04 (77.2)		-	
FI 4	H	- 8T -	0.409 (10.4)	1/2 Hy-Lok	1/2 Hy-Lok	3.42 (86.9)		7/8 (22.2)	
	H	- 12M -		12mm Hy-Lok	12mm Hy-Lok	3.43 (87.2)		0.87 (22.0)	

Dimensions shown with Hy-Lok nuts in finger-tight position, where applicable.

## Ordering Information

**FI**

**Series Designator**

- FI 1 : Orifice 0.094(2.4)
- FI 2 : Orifice 0.187(4.8)
- FI 3 : Orifice 0.281(7.1)
- FI 4 : Orifice 0.409(10.4)

**F**

**End Connection Designator**

- H : Hy-Lok Tube Fitting
- M : Male Pipe Thread
- F : Female Pipe Thread

**4N**

**Size Designator**

**15**

**Fiter Element Designator**

- 05 : 0.5 Micron
- 2 : 2 Micron
- 7 : 7 Micron
- 15 : 15 Micron
- 60 : 60 Micron
- 90 : 90 Micron

**S316**

**Body Material Designator**

- S316 : 316 Stainless Stee
- BRAS : brass

• **NPT ( ISO / BSP )**

Thread (in)	1 / 8	1 / 4	3 / 8	1 / 2
Designation	2N(R)	4N(R)	6N(R)	8N(R)

• **Tube O.D. Designation**

Inch Tube	Tube O.D.	1 / 8	1 / 4	3 / 8	1 / 2
	Designation	2	4	6	8
Metric Tube	Tube O.D.	3mm	6mm	10mm	12mm
	Designation	3M	6M	10M	12M

### SAFETY in VALVE SELECTION

Proper installation, material compatibility, operation and maintenance of these valves are the responsibility of the user. The total system design must be taken into consideration to insure optimal performance and safety.



**FLOWTEKNIK**  
SCANDINAVIA APS

Metalgangen 13  
DK-2690 Karlslunde  
Denmark  
Phone (+45) 73 84 12 30  
[info@pgflowteknik.dk](mailto:info@pgflowteknik.dk)  
[www.pgflowteknik.dk](http://www.pgflowteknik.dk)