

# JUMBO 6



## THE PERFECT COST EFFECTIVE JETTING TANK WASHER

- Large Powerful Jets
- Fast Wash Action
- High Flow Rate
- External Gears
- Reduces Down Time
- Reduced Cleaning Time
- Ideal For Replacing Large Spray Balls
- Non Blocking Design

### Versatile & Unique

The Jumbo 6 uses a simple and effective time proven drive mechanism to ensure low maintenance with a long life. The unique external non blocking gears can be easily checked with a quick visual inspection, reducing the need to remove the unit from the tank. The robust design means the unit can be installed in a wide variety of vessels that require powerful cleaning solution.

### Applications

The Jumbo 6 is ideal for replacing large fixed or rotating spray balls or other jetting units where an powerful impingement clean is required. The high energy, high impact jets provide very effective impingement up to five metres, meaning a single unit can clean vessels up to ten metres in diameter. Robust in design, effective in performance, they meet all the essential FDA material requirements. This makes the units highly suitable for the pharmaceutical, biotech, food, beverage and other hygiene conscious industries.

### Operation

Wash fluid drives a simple rotating turbine, which drives the rotating gears. All the wash fluid exits the unit through the nozzles. The simple reaction drive absorbs very little energy from the wash fluid, providing powerful jets with a minimum amount of wash fluid. The typical full cycle time is 5 to 7 minutes delivering optimum performance in a short timescale.



**Breconcherry**  
SellersClean

# JUMBO 6



Breconcherry Limited,  
Lynden House  
Lynden Business Park  
Ledbury, Herefordshire  
HR8 2DJ, UK

Tel: +44 (0)1531 632476  
Fax: +44 (0)1531 633839  
E-mail: CIP@breconcherry.com



We reserve the right to change specification without notice. Whilst we endeavour to provide accurate up to date information, all information is provided as a guide only.

"Breconcherry", "Chemidisc" are internationally registered trade marks of Breconcherry Limited.  
Copyright © Breconcherry Limited 1999

## Maintenance & Inspection

The low wear design requires minimal maintenance. Any spare parts, technical assistance or repair facilities required can be obtained through the global Breconcherry distributor network. As with all mechanical devices, it is recommended that the unit be regularly inspected for correct operation.

## Manhole Opening

The minimum manhole/flange opening size required for unit insertion is 280mm/11".

## Technical Data

<b>Material of Construction:</b>	Stainless Steel 316/316L, PTFE, C-PTFE, PEEK, Hastelloy
<b>Max. Operating Temperature:</b>	100°C
<b>Max. Ambient Temperature:</b>	140°C
<b>Standard Connection:</b>	1 1/2" BSP/NPT Female
<b>Nozzle Characteristics:</b>	4 Nozzle, 360° Spray Pattern 3/8" 5/16" 1/4" diameter nozzles available.
<b>Weight:</b>	4.4 kg

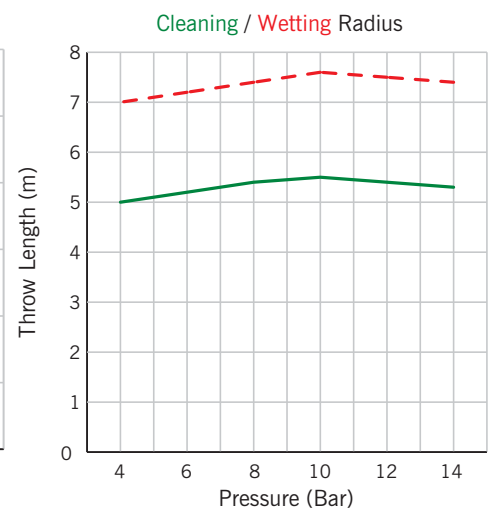
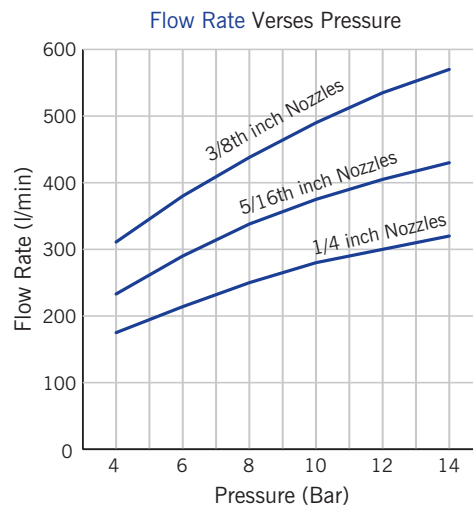

## General Arrangement Drawings

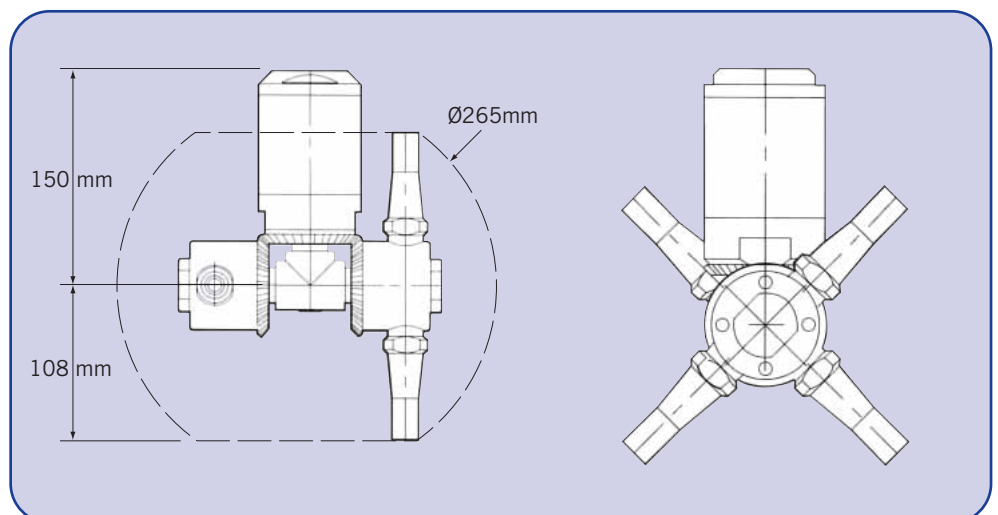

For optimal efficiency use a pre-filter or strainer to prevent particulate clogging.

