

FLOWTEKNIK
SCANDINAVIA APS



Q116

product catalogue





Haelok – the company

Haelok fittings are considered the only mechanical alternative to welding.

Haelok AG, the inventor of one of the world strongest mechanical pipe connection, is a Zurich, Switzerland based privately held company, founded in 2005. The company is ISO 9001 certified and has global product approvals for different uses.

Our international client base and large distribution network proves our ability to provide first class service for global companies and customers.

In short for your pipe connecting challenges – we are your "perfect fit".



table of contents product catalogue 1Q16

Company Profile

The Haelok System
„the perfect fit“ 4

Certification & Approvals 6

Application and
Burst Pressure Tests 7

Pipe Specifications 8

Fitting Catalogue 10

Press Tools 27

Installation Guide 34



Average time to
install a fitting in **constant quality:**
less than one minute, and no need
for certified, specialized labor.

Imagine the benefits.

The HAELOK System, invented and perfected in Switzerland, provides **pure metal to metal sealing**. This unique pipe-connection system, **without gaskets**, ensures highly hermetic sealing for pipe dimensions from 12 mm up to 114.3 mm (4") within a broad temperature range for almost any piping system.

Reliability and quality is machined into HAELOK System's unique design and it's paired with an unparalleled ease of installation.

For many different applications, various pipe diameters, materials, pressures, temperature ranges and fluid contents, HAELOK is "the perfect" fit and can supply the appropriate fitting for the lifetime of your piping system.

Tested and approved up to 1140bar, 16'500 psi.
Metal-to-metal seal and 100% non-welded parts.

Installation Benefits

- ➔ Works in small, difficult to access spaces
- ➔ **No inspection** by X-ray or other methods needed
- ➔ Installation is secure and can be done in any circumstance or weather condition
- ➔ Significantly **faster than welding**
- ➔ Supplied pre-assembled, **very simple installation**
- ➔ No need to completely clean or dry the pipe

Real Cost Benefits

- ➔ **Faster installation**, therefore a real cost advantage
- ➔ **No need for certified, experienced labor**
- ➔ Reducing the overall costs of your installation
- ➔ Works equally well for both welded as well as seamless pipes
- ➔ **No expensive test equipment** needed

HSEQ

- ➔ **No hot works**; fire or explosion risks are minimized
- ➔ No sparks, **no safety issues**
- ➔ **No harmful welding fumes, no glaring light, no intense heat**
- ➔ Pressed permanently sealed
- ➔ **Purely metallic seal without any further material**
- ➔ Supplied pre-assembled, **no assembly errors**
- ➔ Every connection has the same high quality



Haelok Certification & International Certification Standards

Haelok is in full conformity to ASME B31.1 Power Piping, ASME B 31.3 Process Piping and fulfills all requirements of IACS (International Association for Classification of Ships). IACS is regarded as the most demanding industry certification. Haelok is constantly adding additional certifications according to the requirements of the various industries and applications .

Test cycles run include tightness, pull-out, burst pressure, combined pressure pulsation and vibration, vacuum and fire resistance tests.



Approved Swiss Precision Technology.

Inch outside pipe diameter

DN	Size	OD	s (wall thickness)	PN ¹⁾ (Nominal Pressure)	PN ²⁾ (test to IACS)	Burst Pressure test ³⁾
6	1/8"	10,2	1,8	600bar	300bar	1137bar
8	1/4"	13,5	1,8	600bar	300bar	1137bar
10	3/8"	17,2	1,8	400bar	300bar	1137bar
15	1/2"	21,3	2,0	400bar	200bar	800bar
20	3/4"	26,9	2,3	400bar	200bar	800bar
25	1"	33,7	2,6	400bar	200bar	800bar
32	1 1/4"	42,4	2,6	300bar	150bar	600bar
40	1 1/2"	48,3	2,6	300bar	150bar	600bar
50	2"	60,3	2,6	300bar	150bar	600bar

Metric outside pipe diameter

Size	OD	s (wall thickness)	PN ¹⁾ (Nominal Pressure)	PN ²⁾ (test to IACS)	Burst Pressure test ³⁾
10	10	1,5	600bar	300bar	1137bar
12	12	1,5	600bar	300bar	1137bar
16	16	1,5	400bar	200bar	800bar
18	18	1,5	400bar	200bar	800bar
20	20	2	400bar	200bar	800bar
22	22	2	400bar	200bar	800bar
25	25	2,5	400bar	200bar	800bar
28	28	2,5	400bar	200bar	800bar
30	30	3	400bar	200bar	800bar
35	35	3	300bar	150bar	600bar
38	38	3	300bar	150bar	600bar
42	42	3	300bar	150bar	600bar
50	50	3	300bar	150bar	600bar
54	54	3	300bar	150bar	600bar

¹⁾ Pressure for doubled safety factor

²⁾ Nominal pressure PN for shipbuilding

³⁾ Burst pressure proofed at 4-times nominal pressure over 5min

Outer dimensions (OD) are stated in metric values (mm)
Errors and technical changes reserved

Applications and
Burst Pressure Test of our fittings
Temperature ranges

Temperature range is from
-55°C to +400°C according
to material in use.

At elevated temperatures the
maximum working pressures
have to be reduced according
to following table:

Temp C°	Carbon Steel (CC)	Stainless Steel (XX)
50	0%	4%
100	10%	12%
150	21%	15%
200	31%	20%
250	37%	25%
300	45%	30%
350		33%
400		35%

Flow resistance coefficient on
request.

Pipe specifications

Dimensioning of pipes and wall thickness:

The dimensioning of the pipes is done according to DIN 2413 or to ANSI B 31.3 for a given pressure for the particular application. For further specifications consult the pipe manufacturers.

Usable pipes:

- Haelok fittings are usable in combination with carbon steel pipes, annealed stainless steel pipes and primed carbon steel pipes. Seamless, welded and cold rolled pipes are allowed.
- The pipe surface must be clean and without grooves and striations (>0.1 mm grooves are not allowed).
- Loose rolling skin, scale, rust must be removed.
- Hot rolled, or pipes with heavy scaly surfaces are not allowed.
- Max. / Min. diameter and wall thickness must be within specifications.

Inch outside pipe diameter

DN	Size	Allowable pipe diameter		Nominal outer pipe ø according to standard			Allowable pipe wall thickness	
		ID _{max} ^{A)}	ID _{min} ^{B)}	OD1 _{nom} ^{C)}	OD2 _{nom} ^{C)}	OD3 _{nom} ^{C)}	s _{min}	s _{max}
8	¼"	13,70*	13,20	13,50	13,72	–	1,60	2,30
10	⅜"	17,50	16,90	17,20	17,15	–	1,60	2,77
15	½"	21,75	21,00	21,30	21,26	21,30	1,60	2,77
20	¾"	27,30	26,50	26,90	26,67	26,90	2,11	3,91
25	1"	34,20	33,25	33,70	33,41	33,70	2,60	4,55
32	1¼"	42,90	41,90	42,40	42,16	42,40	2,60	5,08
40	1½"	49,10	47,95	48,30	48,26	48,30	2,60	5,08
50	2"	60,80	59,85	60,30	60,33	60,30	2,60	5,54

A) ID_{max} = max pipe diameter allowed to use

B) ID_{min} = min pipe diameter allowed to use

C) OD_{x, nom} = nominal outer pipe diameter

*max standard ø above ID_{max} possible

Metric outside pipe diameter

d	Allowable pipe diameter		Nominal outer pipe ø according to standard		Allowable pipe wall thickness	
	ID _{max} ^{A)}	ID _{min} ^{B)}	OD1 _{nom} ^{C)}	OD2 _{nom} ^{C)}	s _{min}	s _{max}
12	12,10*	11,70	12,00	12,00	1,50	2,00
16	16,20*	15,70	16,00	16,00	1,50	3,00
18	18,30	17,70	18,00	18,00	1,50	3,00
20	20,35	19,70	20,00	20,00	1,50	3,00
22	22,30	21,70	22,00	22,00	1,50	3,00
25	25,30	24,70	25,00	25,00	1,50	3,00
28	28,30	27,70	28,00	28,00	1,50	3,00
30	30,50	29,70	30,00	30,00	1,50	3,00
35	35,30	34,70	35,00	35,00	2,00	3,00
38	38,50	37,70	38,00	38,00	2,00	4,00
42	42,90	41,69	42,00	42,00	2,00	4,00
50	50,50	49,63	50,00	50,00	2,00	5,00
54	54,50	53,60	54,00	54,00	2,00	5,00

Errors and technical changes reserved

Admissible pipe tolerances:

EN ISO 1127 or EN 10220 (OD₁)

Outside diameter D3:

±0,75%, or min. ±0,3mm

Wall thickness T3:

±10%, or min. ±0,2mm

ASTM A213/A268/A269 (OD₂)

Outside diameter D3:

13,72 to 38,1mm: ±0,13mm

38,1 to 88,9mm: ±0,25mm

Wall thickness T3:

±10%

EN 253 (OD₃)

Outside diameter D3:

21.3 (1/2") to 60.3 (2"): ±0,3mm

≥ 60,3: 0.005 x D3

Wall thickness T3:

±0,3mm for tubes with s ≤ 3.2mm

±0,4mm for tubes with s = 3.6mm

±0,5mm for tubes with s ≥ 4 mm

Ovality

The tolerance for the ovality corresponds to the limit of the outside diameter.

Pipe Hardness

Allowed up to a maximum of Rockwell B scale hardness of 90.

STRAIGHT FITTING / STRAIGHT REPAIR 12



REDUCER 14



STRAIGHT THREAD INTERNAL / EXTERNAL 16

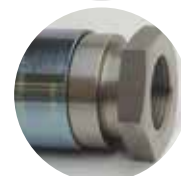

END CAP 18



ELBOW 90° 19



BENDED PIPE 90° 20



UNION TEE 21



DISTRIBUTOR 2 OUTLETS / 4 OUTLETS 22



DKO / FLANGE 23





Fitting product catalogue

for carbon steel pipes

according to EN253, EN10217-5, EN10217-6, EN10255

for stainless steel pipes

according to EN10216-5, EN10217-7

material **CC:**

Pipe fitting materials:

Body: Carbon steel 1.0570 (AISI 1024) galvanized, Press ring: Carbon steel 1.0570 (AISI 1024) galvanized

material **XC:**

Pipe fitting materials:

Body: Stainless steel 1.4404 (AISI 316L), Press ring: Carbon steel 1.0570 (AISI 1024) galvanized

material **XX:**

Pipe fitting materials:

Body: Stainless steel 1.4404 (AISI 316L), Press ring: Stainless steel 1.4404 (AISI 316L)

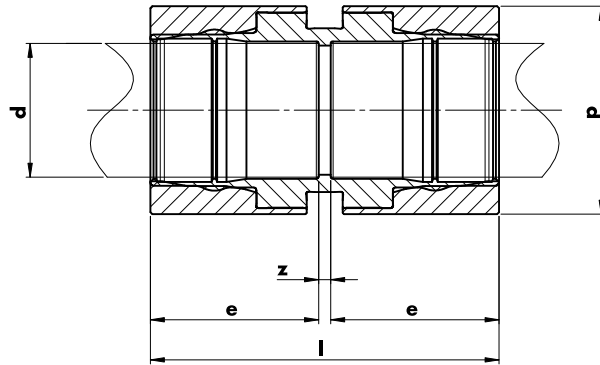
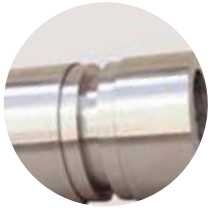

Straight Fitting (Metric pipe)

Metric outside diameter

d	Article No.	p	l	e	z	Weight (g)
10	HLK-10SF-10-__	22	37	17	3	65
12	HLK-10SF-12-__	22	37	17	3	70
16	HLK-10SF-16-__	27	52	25	2	133
18	HLK-10SF-18-__	29	52	25	2	150
20	HLK-10SF-20-__	32	52	25	2	180
22	HLK-10SF-22-__	34	52	25	2	190
25	HLK-10SF-25-__	37	52	25	2	210
28	HLK-10SF-28-__	40	52	25	2	229
30	HLK-10SF-30-__	47	87	42	3	641
35	HLK-10SF-35-__	55	87	42	3	818
38	HLK-10SF-38-__	55	87	42	3	776
54	HLK-10SF-54-__	74	87	42	3	1206

Straight Fitting (Inch pipe)

Inch outside diameter

d	Article No.	p	l	e	z	Weight (g)
1/4"	HLK-10SF-13-__	22	37	17	3	55
3/8"	HLK-10SF-17-__	29	52	25	2	160
1/2"	HLK-10SF-21-__	34	52	25	2	187
3/4"	HLK-10SF-26-__	39	52	25	2	223
1"	HLK-10SF-33-__	52	87	42	3	770
1 1/4"	HLK-10SF-42-__	61	87	42	3	941
1 1/2"	HLK-10SF-48-__	68	87	42	3	1108
2"	HLK-10SF-60-__	82	87	42	3	1445
2 1/2"	HLK-10SF-76-__	98	155	75	5	2800
3"	HLK-10SF-88-__	116	155	75	5	4800
4"	HLK-10SF-114-__	141	155	75	5	5800

All dimensions in millimeters, except specially marked
Errors and technical changes reserved

Material and Order Codes

- CC:** Body & Press-Ring: Steel Galvanized: Example: HLK-10SF-12-CC
- XC:** Body: Stainless Steel; Press-Ring: Steel galvanized: Example: HLK-10SF-12-XC
- XX:** Body & Press-Ring: Stainless Steel: Example: HLK-10SF-12-XX

Other dimensions or materials on request

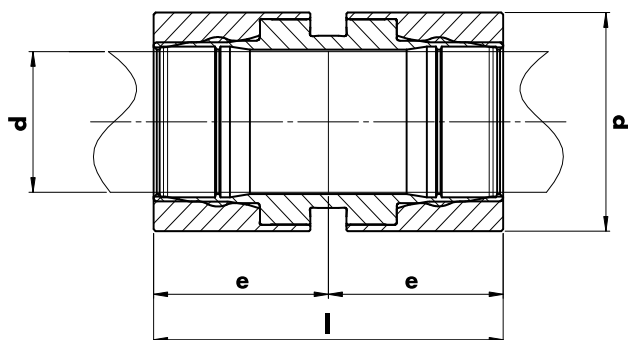

Straight Repair (Metric pipe)

Metric outside diameter

d	Article No.	p	l	e	Weight (g)
10	HLK-10SR-10-__	22	37	18.5	65
12	HLK-10SR-12-__	22	37	18.5	70
16	HLK-10SR-16-__	27	52	26	133
18	HLK-10SR-18-__	29	52	26	150
20	HLK-10SR-20-__	32	52	26	180
22	HLK-10SR-22-__	34	52	26	190
25	HLK-10SR-25-__	37	52	26	210
28	HLK-10SR-28-__	40	52	26	229
30	HLK-10SR-30-__	47	87	43.5	641
35	HLK-10SR-35-__	55	87	43.5	818
38	HLK-10SR-38-__	55	87	43.5	776
54	HLK-10SR-54-__	74	87	43.5	1206

Straight Repair (Inch pipe)

Inch outside diameter

d	Article No.	p	l	e	Weight (g)
1/4"	HLK-10SR-13-__	22	37	18.5	55
3/8"	HLK-10SR-17-__	29	52	26	160
1/2"	HLK-10SR-21-__	34	52	26	187
3/4"	HLK-10SR-26-__	39	52	26	223
1"	HLK-10SR-33-__	52	87	43,5	770
1 1/4"	HLK-10SR-42-__	61	87	43,5	941
1 1/2"	HLK-10SR-48-__	68	87	43,5	1108
2"	HLK-10SR-60-__	82	87	43,5	1445
2 1/2"	HLK-10SR-76-__	98	155	77,5	2800
3"	HLK-10SR-88-__	116	155	77,5	4800
4"	HLK-10SR-114-__	141	155	77,5	5800

All dimensions in millimeters, except specially marked
 Errors and technical changes reserved

Material and Order Codes

- CC:** Body & Press-Ring: Steel Galvanized: Example: HLK-10SR-12-CC
- XC:** Body: Stainless Steel; Press-Ring: Steel galvanized: Example: HLK-10SR-12-XC
- XX:** Body & Press-Ring: Stainless Steel: Example: HLK-10SR-12-XX

Other dimensions or materials on request

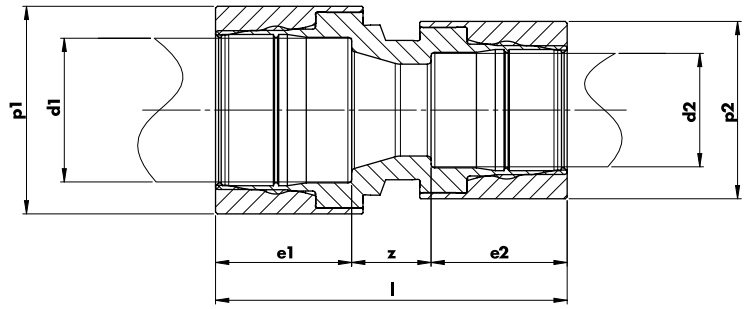

Reducer (Metric pipe)

Metric outside diameter

d1	d2	Article No.	p ₁	e ₁	p ₂	e ₂	l	z	Weight (g)
12	10	HLK-10RE-12-10-__	22	17	22	17	37	3	85
16	12	HLK-10RE-16-12-__	27	25	22	17	45	3	133
18	12	HLK-10RE-18-12-__	29	25	22	17	45	3	180
20	16	HLK-10RE-20-16-__	32	25	27	25	58	8	180
22	18	HLK-10RE-22-18-__	34	25	29	25	58	8	190
25	20	HLK-10RE-25-20-__	37	25	32	25	58	8	210
28	22	HLK-10RE-28-22-__	40	25	34	25	58	8	229
30	25	HLK-10RE-30-25-__	47	42	37	25	75	8	641
35	28	HLK-10RE-35-28-__	55	42	40	25	75	8	760
35	22	HLK-10RE-35-22-__	55	42	34	25	75	8	760
38	30	HLK-10RE-38-30-__	55	42	47	42	100	16	776
38	28	HLK-10RE-38-28-__	55	42	40	25	75	8	776
54	42	HLK-10RE-54-42-__	74	42	61	42	100	16	1206
54	35	HLK-10RE-54-35-__	74	42	55	42	100	16	1206
54	28	HLK-10RE-54-28-__	74	42	40	25	75	8	1206
54	22	HLK-10RE-54-22-__	74	42	34	25	75	8	1206

All dimensions in millimeters, except specially marked
Errors and technical changes reserved

Material and Order Codes

- CC:** Body & Press-Ring: Steel Galvanized: Example: HLK-10RE-18-12-CC
- XC:** Body: Stainless Steel; Press-Ring: Steel galvanized: Example: HLK-10RE-18-12-XC
- XX:** Body & Press-Ring: Stainless Steel: Example: HLK-10RE-18-12-XX

Other dimensions or materials on request

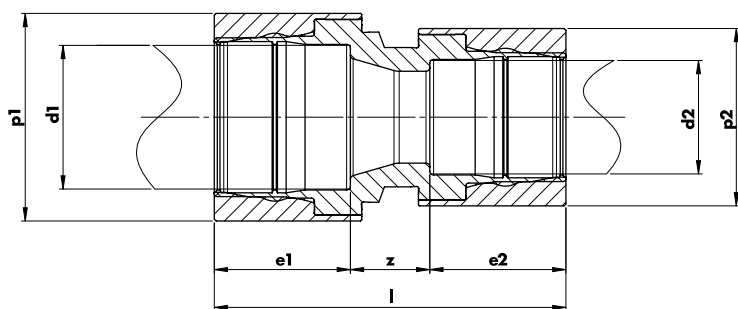

Reducer (Inch pipe)

Inch outside diameter

d1	d2	Article No.	p ₁	e ₁	p ₂	e _d	l	z	Weight (g)
3/8"	1/4"	HLK-10RE-17-13-__	29	25	22	17	45	3	140
1/2"	3/8"	HLK-10RE-21-17-__	34	25	29	25	55	5	180
1/2"	1/4"	HLK-10RE-21-13-__	34	25	22	17	45	3	180
3/4"	1/4"	HLK-10RE-26-17-__	39	25	29	17	45	3	190
3/4"	1/2"	HLK-10RE-26-21-__	39	25	34	25	58	8	220
1"	3/4"	HLK-10RE-33-26-__	52	42	39	25	75	8	770
1"	1/2"	HLK-10RE-33-21-__	52	42	34	25	75	8	770
1 1/4"	1"	HLK-10RE-42-33-__	61	42	52	42	100	16	941
1 1/4"	3/4"	HLK-10RE-42-26-__	61	42	39	25	75	8	941
1 1/4"	1/2"	HLK-10RE-42-21-__	61	42	34	25	75	8	941
1 1/2"	1 1/4"	HLK-10RE-48-42-__	68	42	61	42	100	16	1108
1 1/2"	1"	HLK-10RE-48-33-__	68	42	52	42	100	16	1108
1 1/2"	3/4"	HLK-10RE-48-26-__	68	42	39	25	75	8	1108
2"	1 1/2"	HLK-10RE-60-48-__	82	42	68	42	100	16	1444
2"	1 1/4"	HLK-10RE-60-42-__	82	42	61	42	100	16	1444
2"	1"	HLK-10RE-60-33-__	82	42	52	42	100	16	1444

d1	d2	Article No.	p ₁	e ₁	p ₂	e _d	l	z	Weight (g)
1"	28	HLK-10RE-33-28-__	52	42	40	25	75	8	770
1"	22	HLK-10RE-33-22-__	52	42	34	25	75	8	770
1"	18	HLK-10RE-33-18-__	52	42	29	25	75	8	770
1 1/4"	22	HLK-10RE-42-22-__	61	42	34	25	75	8	941
1 1/2"	30	HLK-10RE-48-30-__	68	42	47	42	100	16	1108
1 1/2"	28	HLK-10RE-48-28-__	68	42	40	25	75	8	1108

All dimensions in millimeters, except specially marked
Errors and technical changes reserved

Material and Order Codes

- CC:** Body & Press-Ring: Steel Galvanized: Example: HLK-10RE-17-13-CC
- XC:** Body: Stainless Steel; Press-Ring: Steel galvanized: Example: HLK-10RE-17-13-XC
- XX:** Body & Press-Ring: Stainless Steel: Example: HLK-10RE-17-13-XX

Other dimensions or materials on request

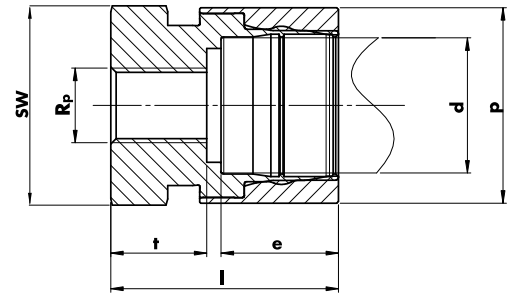
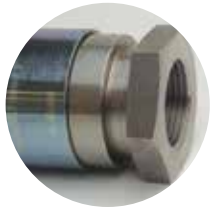

Straight Thread Internal (Metric pipe)

Metric outside diameter

d	R _p ¹⁾	Article No.	p	l	e	t	SW	Weight (g)
12	1/4"	HLK-10TI-12-R14- _ _	22	40	17	13	19	80
16	3/8"	HLK-10TI-16-R38- _ _	27	47	25	13	24	120
18	3/8"	HLK-10TI-18-R38- _ _	29	47	25	13	24	120
20	1/2"	HLK-10TI-20-R12- _ _	32	53	25	18	27	150
22	1/2"	HLK-10TI-22-R12- _ _	34	53	25	18	30	160
25	3/4"	HLK-10TI-25-R34- _ _	37	53	25	18	32	170
28	3/4"	HLK-10TI-28-R34- _ _	40	53	25	18	36	200
30	3/4"	HLK-10TI-30-R34- _ _	47	63	42	19	41	400
35	1"	HLK-10TI-35-R1- _ _	55	73	42	22	46	600
38	1"	HLK-10TI-38-R1- _ _	55	73	42	22	46	600
54	2"	HLK-10TI-54-R2- _ _	74	73	42	29	65	1070

Straight Thread Internal (Inch pipe)

Inch outside diameter

d	R _p ¹⁾	Article No.	p	l	e	t	SW	Weight (g)
1/4"	1/4"	HLK-10TI-13-R14- _ _	22	40	17	13	19	100
3/8"	3/8"	HLK-10TI-17-R38- _ _	29	47	25	12	14	120
1/2"	1/2"	HLK-10TI-21-R12- _ _	34	53	25	18	27	150
3/4"	3/4"	HLK-10TI-26-R34- _ _	39	53	25	18	36	190
1"	1"	HLK-10TI-33-R1- _ _	52	73	42	22	46	520
1 1/4"	1 1/4"	HLK-10TI-42-R114- _ _	61	76	42	24	55	700
1 1/2"	1 1/2"	HLK-10TI-48-R112- _ _	68	78	42	26	60	830
2"	2"	HLK-10TI-60-R2- _ _	82	80	42	29	75	1070

All dimensions in millimeters, except specially marked
Errors and technical changes reserved

¹⁾R_p: Cylindrical internal thread with pressure tight joints in the thread according to EN 10226-1 - other types NPT etc. on request
Remark: R and G type threads are identical.

Material and Order Codes

- CC:** Body & Press-Ring: Steel Galvanized: Example: HLK-10TI-33G1-CC
- XC:** Body: Stainless Steel; Press-Ring: Steel galvanized: Example: HLK-10TI-33G1-XC
- XX:** Body & Press-Ring: Stainless Steel: Example: HLK-10TI-33G1-XX

Other dimensions or materials on request

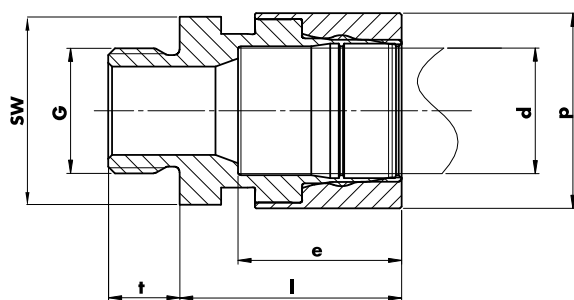

Straight Thread External (Metric pipe)

Metric outside diameter

d	G ²⁾	Article No.	p	l	e	t	SW	Weight (g)
12	1/4"	HLK-10TE-12-G14- __	22	20	17	9	22	80
16	3/8"	HLK-10TE-16-G38- __	27	28	25	12	27	120
18	3/8"	HLK-10TE-18-G38- __	29	28	25	12	27	120
20	1/2"	HLK-10TE-20-G12- __	32	28	25	16	32	150
22	1/2"	HLK-10TE-22-G12- __	34	28	25	16	32	150
25	3/4"	HLK-10TE-25-G34- __	37	28	25	17	41	170
28	3/4"	HLK-10TE-28-G34- __	40	28	25	17	41	200
30	3/4"	HLK-10TE-30-G34- __	47	45	42	17	41	400
35	1"	HLK-10TE-35-G1- __	55	45	42	19	50	600
38	1"	HLK-10TE-38-G1- __	55	45	42	22	50	650
54	2"	HLK-10TE-54-G2- __	74	45	42	24	72	950

Straight Thread External (Inch pipe)

Inch outside diameter

d	G ²⁾	Article No.	p	l	e	t	SW	Weight (g)
1/4"	1/4"	HLK-10TE-13-G14- __	22	25	17	9	22	100
3/8"	3/8"	HLK-10TE-17-G38- __	29	25	25	12	27	120
1/2"	1/2"	HLK-10TE-21-G12- __	34	25	25	16	32	150
3/4"	3/4"	HLK-10TE-26-G34- __	39	39	25	17	36	190
1"	1"	HLK-10TE-33-G1- __	52	59	42	17	46	520
1 1/4"	1 1/4"	HLK-10TE-42-G114- __	61	59	42	20	55	700
1 1/2"	1 1/2"	HLK-10TE-48-G112- __	68	59	42	20	60	830
2"	2"	HLK-10TE-60-G2- __	82	62	42	22	75	1070

All dimensions in millimeters, except specially marked
Errors and technical changes reserved

²⁾G: Cylindrical external thread where pressure tight joints are not made on the treads according to ISO 228-1 - other types (R or NPT etc.) on request

Material and Order Codes

CC: Body & Press-Ring: Steel Galvanized: Example: HLK-10TE-13-G14-CC
XC: Body: Stainless Steel; Press-Ring: Steel galvanized: Example: HLK-10TE-13-G14-XC
XX: Body & Press-Ring: Stainless Steel: Example: HLK-10TE-13-G14-XX

Other dimensions or materials on request

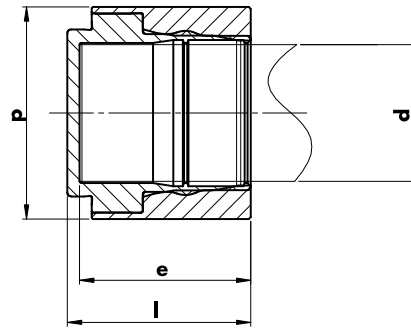

End Cap (Metric pipe)

Metric outside diameter

d	Article No.	p	l	e	Weight (g)
12	HLK-10EC-12-__	22	22	17	55
16	HLK-10EC-16-__	27	30	25	70
18	HLK-10EC-18-__	29	30	25	80
20	HLK-10EC-20-__	32	30	25	80
22	HLK-10EC-22-__	34	30	25	105
25	HLK-10EC-25-__	37	30	25	115
28	HLK-10EC-28-__	40	30	25	131
30	HLK-10EC-30-__	47	47	42	340
35	HLK-10EC-35-__	55	47	42	410
38	HLK-10EC-38-__	55	47	42	419
54	HLK-10EC-54-__	74	47	42	720

End Cap (Inch pipe)

Inch outside diameter

d	Article No.	p	l	e	Weight (g)
1/4"	HLK-10EC-13-__	22	22	17	55
3/8"	HLK-10EC-17-__	29	30	25	70
1/2"	HLK-10EC-21-__	34	30	25	95
3/4"	HLK-10EC-26-__	39	30	25	126
1"	HLK-10EC-33-__	52	47	42	411
1 1/4"	HLK-10EC-42-__	61	47	42	508
1 1/2"	HLK-10EC-48-__	68	47	42	620
2"	HLK-10EC-60-__	82	47	42	792

All dimensions in millimeters, except specially marked
Errors and technical changes reserved

Material and Order Codes

- CC:** Body & Press-Ring: Steel Galvanized: Example: HLK-10EC-17-CC
- XC:** Body: Stainless Steel; Press-Ring: Steel galvanized: Example: HLK-10EC-17-XC
- XX:** Body & Press-Ring: Stainless Steel: Example: HLK-10EC-17-XX

Other dimensions or materials on request

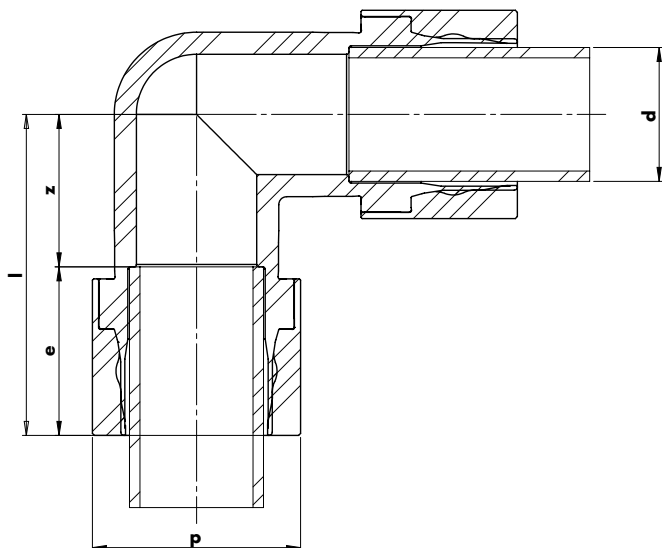

no welded parts!

Elbow 90° (Metric pipe)

Metric outside diameter

d	Article No.	p	l	e	z	Weight (g)
12	HLK-10L90-12-__	22	50	17	33	114
16	HLK-10L90-16-__	27	60	25	35	290
18	HLK-10L90-18-__	29	60	25	35	273
20	HLK-10L90-20-__	32	65	25	40	380
22	HLK-10L90-22-__	34	65	25	40	365
25	HLK-10L90-25-__	37	65	25	40	480
28	HLK-10L90-28-__	40	65	25	40	424
30	HLK-10L90-30-__	47	80	42	38	982

Elbow 90° (Inch pipe)

Inch outside diameter

d	Article No.	p	l	e	z	Weight (g)
1/4"	HLK-10L90-13-__	22	50	17	33	109
3/8"	HLK-10L90-17-__	29	60	25	35	273
1/2"	HLK-10L90-21-__	34	65	25	40	368
3/4"	HLK-10L90-26-__	39	65	25	40	437
1"	HLK-10L90-33-__	52	80	42	38	1124

All dimensions in millimeters, except specially marked
Errors and technical changes reserved

Material and Order Codes

- CC:** Body & Press-Ring: Steel Galvanized: Example: HLK-10L9-13-CC
- XC:** Body: Stainless Steel; Press-Ring: Steel galvanized: Example: HLK-10L9-13-XC
- XX:** Body & Press-Ring: Stainless Steel: Example: HLK-10L9-13-XX

Other dimensions or materials on request

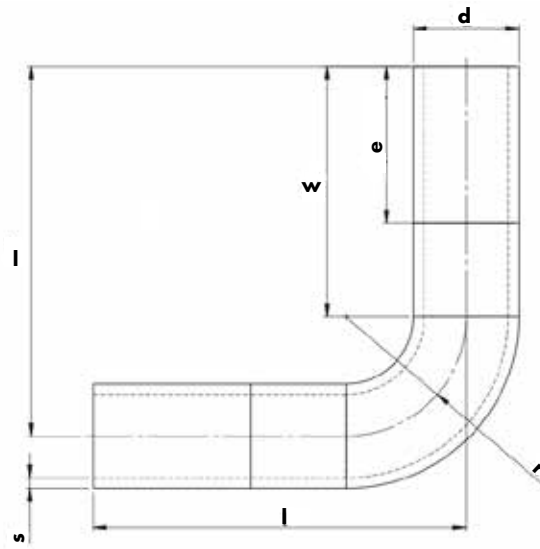

Banded Pipe 90° (Metric pipe)

Metric outside diameter

d	Article No.	r	s	e	w	l	Weight (g)
35	HLK-10BP90-35- _	70	3	42	100	170	500
38	HLK-10BP90-38- _	70	3	42	100	170	500
54	HLK-10BP90-54- _	100	3,2	42	100	200	1400

Banded Pipe 90° (Inch pipe)

Inch outside diameter

d	Article No.	r	s	e	w	l	Weight (g)
1¼"	HLK-10BP90-42- _	85	3,2	42	100	185	600
1½"	HLK-10BP90-48- _	100	3,2	42	100	200	1000
2"	HLK-10BP90-60- _	120	3,6	42	100	220	1600

All dimensions in millimeters, except specially marked
Errors and technical changes reserved



For 90° shapes Haelok offers banded pipes in connection with our straight fittings. The connection is done with two straight fittings.

Please contact your customer service representative for further information.

Delivery is banded pipe only
Please add corresponding fittings (Straight-, Tee-, etc.) according to your usage to the order.

Material and Order Codes

C: Body: Steel Galvanized: Example: HLK-10BP90-42-C
X: Body: Stainless Steel: Example: HLK-10BP90-42-X

Other dimensions or materials on request

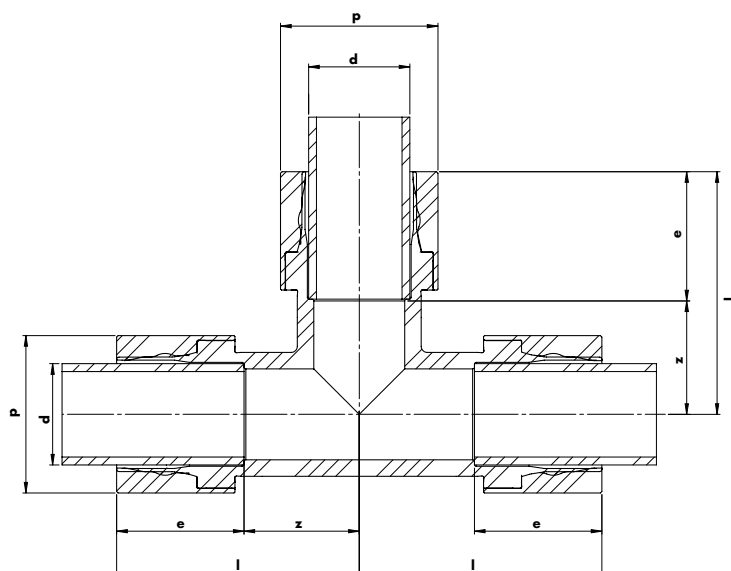

no welded parts!

Union Tee (Metric pipe)

Metric outside diameter

d	Article No.	p	l	e	z	Weight (g)
12	HLK-10T3-12-__	22	50	17	33	157
16	HLK-10T3-16-__	27	60	25	35	400
18	HLK-10T3-18-__	29	60	25	35	364
20	HLK-10T3-20-__	32	65	25	40	498
22	HLK-10T3-22-__	34	65	25	40	485
25	HLK-10T3-25-__	37	65	25	40	612
28	HLK-10T3-28-__	40	65	25	40	555
30	HLK-10T3-30-__	47	80	42	38	1316
35	HLK-10T3-35-__	55	80	42	38	1702
38	HLK-10T3-38-__	55	80	42	38	1606
54	HLK-10T3-54-__	74	100	42	58	3364

Union Tee (Inch pipe)

Inch outside diameter

d	Article No.	p	l	e	z	Weight (g)
1/4"	HLK-10T3-13-__	22	50	17	33	153
3/8"	HLK-10T3-17-__	29	60	25	35	362
1/2"	HLK-10T3-21-__	34	65	25	40	487
3/4"	HLK-10T3-26-__	39	65	25	40	570
1"	HLK-10T3-33-__	52	80	42	38	1586
1 1/4"	HLK-10T3-42-__	61	95	42	53	2443
1 1/2"	HLK-10T3-48-__	68	95	42	53	2435
2"	HLK-10T3-60-__	82	100	42	58	3428

All dimensions in millimeters, except specially marked
Errors and technical changes reserved

Material and Order Codes

- CC:** Body & Press-Ring: Steel Galvanized: Example: HLK-10T3-13-CC
- XC:** Body: Stainless Steel; Press-Ring: Steel galvanized: Example: HLK-10T3-13-XC
- XX:** Body & Press-Ring: Stainless Steel: Example: HLK-10T3-13-XX

Other dimensions or materials on request

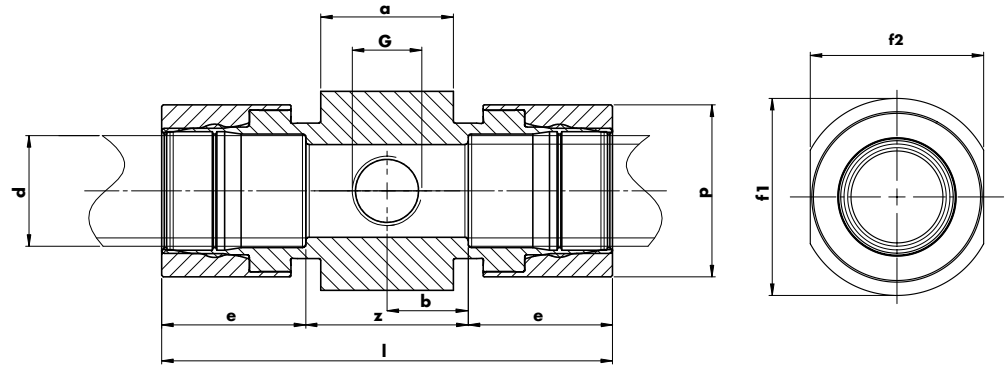
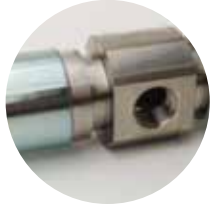

Distributor 2 Outlets (Metric pipe)

Metric outside diameter

d	Article No.	p	l	e	a	b	f ₁	f ₂	G ¹⁾	z	Weight (g)
18	HLK-10D2-18-G38- _ _	29	99	25	40	24,5	49,5	40,5	3/8"	49	660
20	HLK-10D2-20-G38- _ _	32	99	25	40	24,5	49,5	40,5	3/8"	49	640
22	HLK-10D2-22-G12- _ _	34	99	25	40	24,5	49,5	40,5	1/2"	49	624
25	HLK-10D2-25-G12- _ _	37	99	25	40	24,5	49,5	40,5	1/2"	49	630
28	HLK-10D2-28-G12- _ _	40	99	25	40	24,5	49,5	40,5	1/2"	49	609
30	HLK-10D2-30-G12- _ _	47	136	43,5	40	24,5	54,5	46,5	1/2"	49	1153
35	HLK-10D2-35-G12- _ _	55	136	43,5	40	24,5	60	52,8	1/2"	49	1395
38	HLK-10D2-38-G12- _ _	55	136	43,5	40	24,5	60	52,8	1/2"	49	1398
54	HLK-10D2-54-G12- _ _	74	136	43,5	40	24,5	89,5	84,8	1/2"	49	2300

Distributor 2 Outlets (Inch pipe)

Inch outside diameter

d	Article No.	p	l	e	a	b	f ₁	f ₂	G ¹⁾	z	Weight (g)
3/8"	HLK-10D2-17-G38- _ _	29	99	25	40	24,5	49,5	40,5	3/8"	49	680
1/2"	HLK-10D2-21-G38- _ _	34	99	25	40	24,5	49,5	40,5	3/8"	49	630
3/4"	HLK-10D2-26-G12- _ _	39	99	25	40	24,5	49,5	40,5	1/2"	49	612
1"	HLK-10D2-33-G12- _ _	52	136	43,5	40	24,5	60	52,8	1/2"	49	1419
1 1/4"	HLK-10D2-42-G12- _ _	61	136	43,5	40	24,5	64,5	57,9	1/2"	49	1583
1 1/2"	HLK-10D2-48-G12- _ _	68	136	43,5	40	24,5	69,5	63,4	1/2"	49	1779
2"	HLK-10D2-60-G12- _ _	82	136	43,5	40	24,5	89,5	84,8	1/2"	49	2683

All dimensions in millimeters, except specially marked
Errors and technical changes reserved

¹⁾G: Cylindrical internal thread according to ISO 228-1 - other types on request

Material and Order Codes

- CC:** Body & Press-Ring: Steel Galvanized: Example: HLK-10D2-21-G12-CC
- XC:** Body: Stainless Steel; Press-Ring: Steel galvanized: Example: HLK-10D2-21-G12-XC
- XX:** Body & Press-Ring: Stainless Steel: Example: HLK-10D2-21-G12-XX

Other dimensions or materials on request

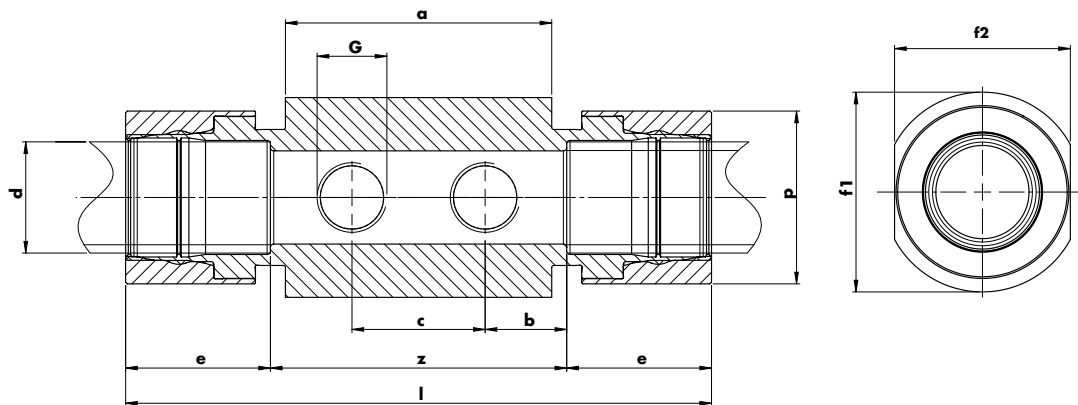

Distributor 4 Outlets (Metric pipe)

Metric outside diameter

d	Article No.	p	l	e	a	b	c	f ₁	f ₂	G ¹⁾	z	Weight (g)
18	HLK-10D4-18-G38-__	29	139	25	80	19,5	50	49,5	40,5	3/8"	89	1060
20	HLK-10D4-20-G38-__	32	139	25	80	19,5	50	49,5	40,5	3/8"	89	1040
22	HLK-10D4-22-G12-__	34	139	25	80	19,5	50	49,5	40,5	1/2"	89	1043
25	HLK-10D4-25-G12-__	37	139	25	80	19,5	50	49,5	40,5	1/2"	89	1030
28	HLK-10D4-28-G12-__	40	139	25	80	19,5	50	49,5	40,5	1/2"	89	971
30	HLK-10D4-30-G12-__	47	176	43,5	80	19,5	50	54,5	46,5	1/2"	89	1628
35	HLK-10D4-35-G12-__	55	176	43,5	80	19,5	50	60	52,8	1/2"	89	1960
38	HLK-10D4-38-G12-__	55	176	43,5	80	19,5	50	60	52,8	1/2"	89	1963
54	HLK-10D4-54-G12-__	74	176	43,5	80	19,5	50	89,5	84,8	1/2"	89	3849

Distributor 4 Outlets (Inch pipe)

Inch outside diameter

d	Article No.	p	l	e	a	b	c	f ₁	f ₂	G ¹⁾	z	Weight (g)
3/8"	HLK-10D4-17-G38-__	29	139	25	80	19,5	50	49,5	40,5	3/8"	89	1080
1/2"	HLK-10D4-21-G38-__	34	139	25	80	19,5	50	49,5	40,5	1/2"	89	1040
3/4"	HLK-10D4-26-G12-__	39	139	25	80	19,5	50	49,5	40,5	1/2"	89	984
1"	HLK-10D4-33-G12-__	52	176	43,5	80	19,5	50	60	52,8	1/2"	89	2021
1 1/4"	HLK-10D4-42-G12-__	61	176	43,5	80	19,5	50	64,5	57,9	1/2"	89	2176
1 1/2"	HLK-10D4-48-G12-__	68	176	43,5	80	19,5	50	69,5	63,4	1/2"	89	2401
2"	HLK-10D4-60-G12-__	82	176	43,5	80	19,5	50	89,5	84,8	1/2"	89	3849

All dimensions in millimeters, except specially marked
 Errors and technical changes reserved

¹⁾G: Cylindrical internal thread according to ISO 228-1 - other types on request

Material and Order Codes

CC: Body & Press-Ring: Steel Galvanized: Example: HLK-10D4-21-G12-CC
XC: Body: Stainless Steel; Press-Ring: Steel galvanized: Example: HLK-10D4-21-G12-XC
XX: Body & Press-Ring: Stainless Steel: Example: HLK-10D4-21-G12-XX

Other dimensions or materials on request



SAE Flange (Inch pipe) to ISO 6162-1 (Code 61)

Inch outside diameter

d	Article No.	p	l	e	g	C	D	E	F	øA	øB	d5	Weight (g)
1"	HLK-10FS-33- _ _	51.9	127	42	44.45	52.4	24	16	10.5	45.3	38.5	28	670

All dimensions in millimeters, except specially marked
Errors and technical changes reserved

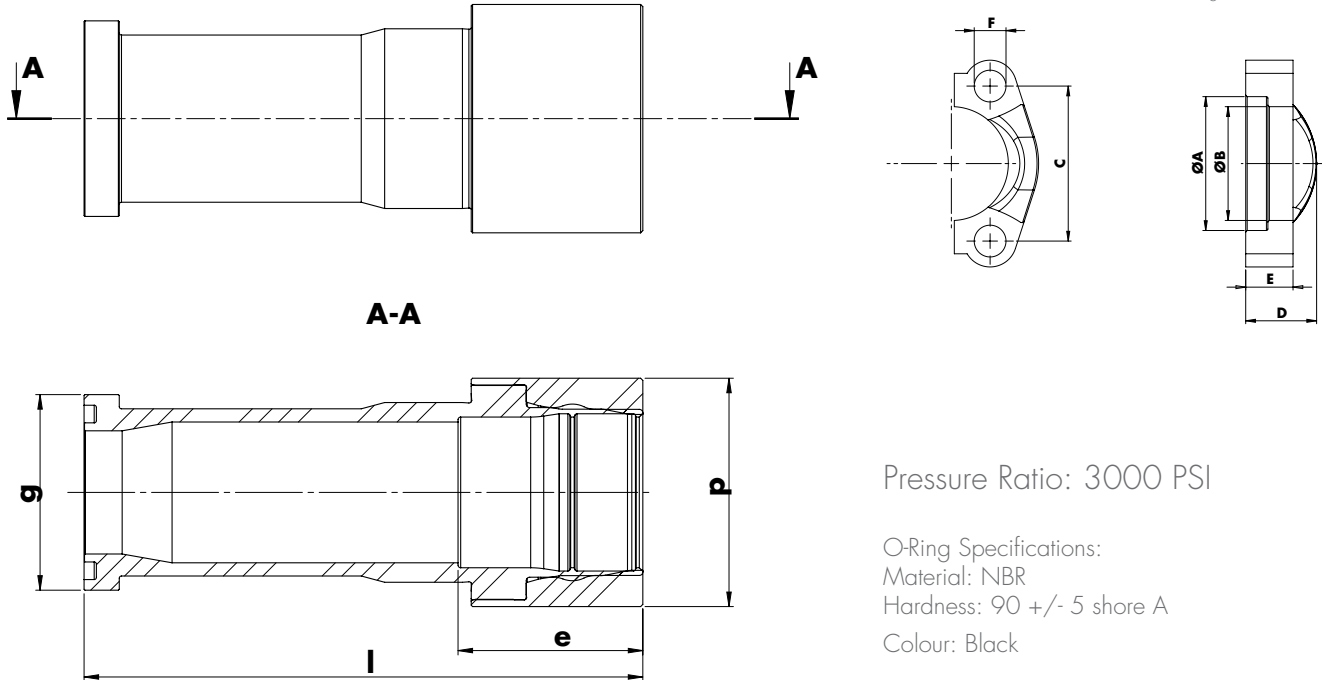

Pressure Ratio: 3000 PSI

O-Ring Specifications:
Material: NBR
Hardness: 90 +/- 5 shore A
Colour: Black

SAE Flanges will be delivered including its supporting half-flanges, screws (Size M10x30 SW8) and O-Ring.

other flange combinations and dimenesions are available

Material and Order Codes

- CC:** Body & Press-Ring: Steel Galvanized: Example: HLK-10FS-33-CC
- XC:** Body: Stainless Steel; Press-Ring: Steel galvanized: Example: HLK-10FS-33-XC
- XX:** Body & Press-Ring: Stainless Steel: Example: HLK-10FS-33-XX

Other dimensions or materials on request



ASME / ANSI Flange (Inch pipe) to ASME B16.5

Metric outside diameter

d	Article No.	p	l	e	d2	d3	d4	d5	d6	Weight (g)
1"	HLK-10FA-33-__	51.9	134	42	19	88.9	125	26.7	50.8	2105

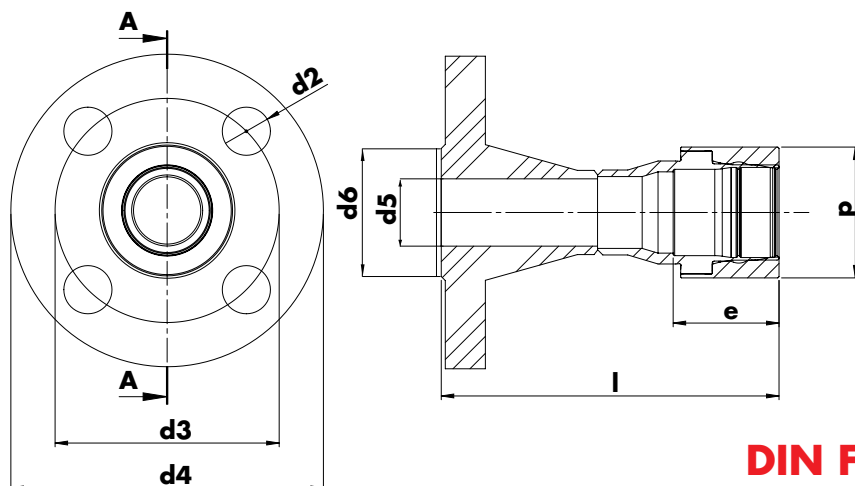

Pressure Ratio: 300 lbs/sq.in.

DIN Flange (Inch pipe) to DIN 2633

Metric outside diameter

d	Article No.	p	l	e	d2	d3	d4	d5	d6	Weight (g)
1"	HLK-10FD-33-__	51.9	120	42	14	85	115	28.5	85	1623

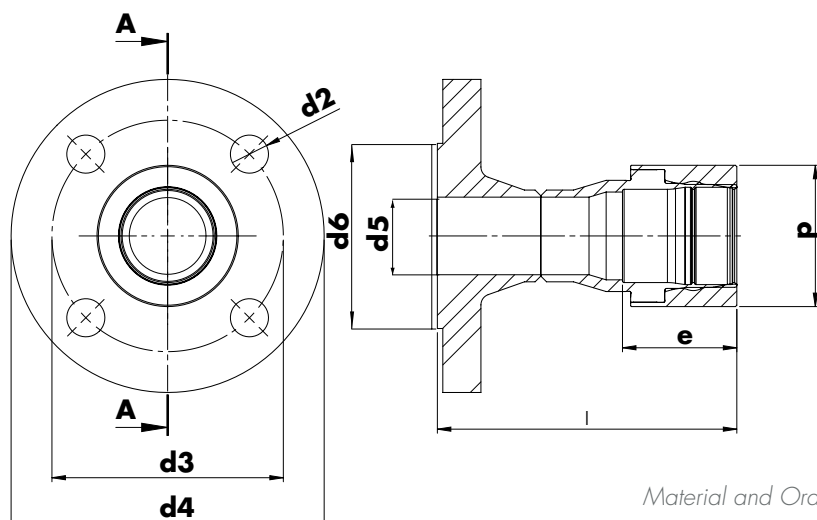

Pressure Ratio: PN 16 (bar)

Material and Order Codes

- CC:** Body & Press-Ring: Steel Galvanized: Example: HLK-10FA-33-CC
- XC:** Body: Stainless Steel; Press-Ring: Steel galvanized: Example: HLK-10FD-33-XC
- XX:** Body & Press-Ring: Stainless Steel: Example: HLK-10FD-33-XX

Other dimensions or materials on request



DKO 24° swivel connector

Metric outside diameter

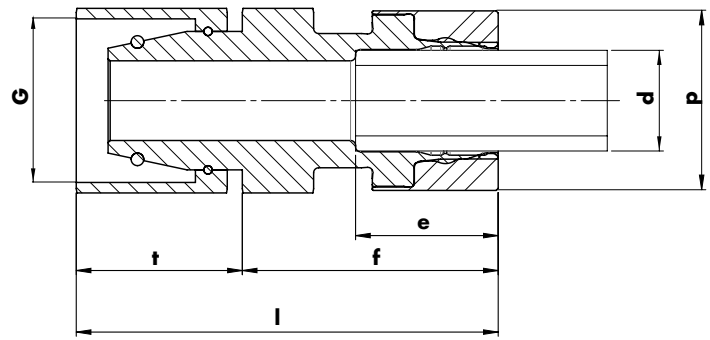

d	Article No.	p	d	e	f	t	l	G	SW	Weight (g)
12	HLK-10CM-12- _ _	21,4	12	17	30,5	19,8	50,3	M16x1.5	22	109

All dimensions in millimeters, except specially marked
Errors and technical changes reserved

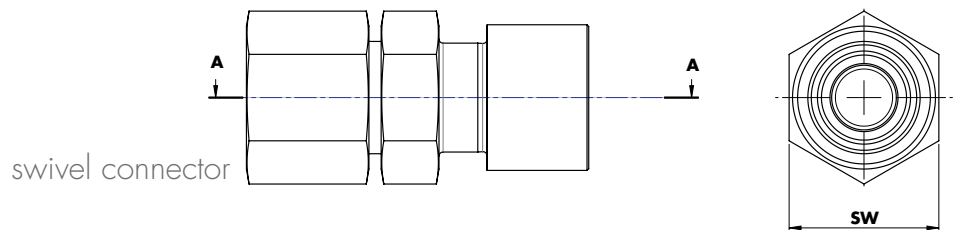

DKO 24° cone end

Metric outside diameter

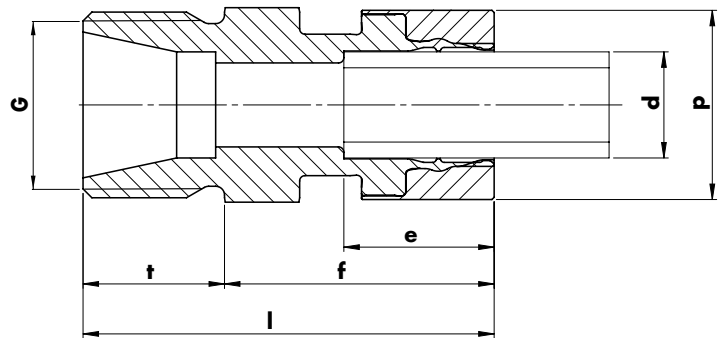

d	Article No.	p	d	e	f	t	l	G	SW	Weight (g)
12	HLK-10CF-12- _ _	21,4	12	17	30,5	16	46,5	M16x1.5	22	90

All dimensions in millimeters, except specially marked
Errors and technical changes reserved

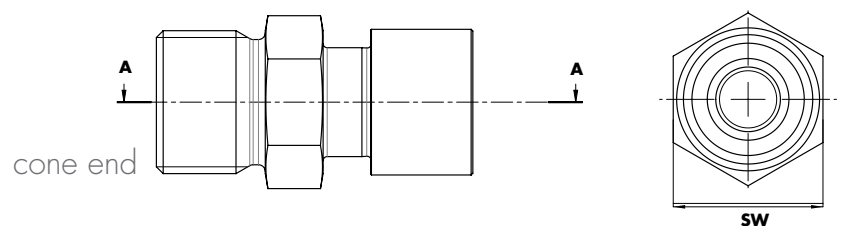

Material and Order Codes

- CC:** Body & Press-Ring: Steel Galvanized: Example: HLK-10CM-33-CC:
- XC:** Body: Stainless Steel; Press-Ring: Steel galvanized: Example: HLK-10CM-33-XC
- XX:** Body & Press-Ring: Stainless Steel: Example: HLK-10CF33-XX

Other dimensions or materials on request

The Haelok Press Tools a complete system

Haelok Press Tools

The hydraulic installation tool behind the world's strongest mechanical pipe connection, installs the HAELOK fittings in a few simple steps.

It delivers everytime accurate, reliable and repeatable results, regardless of the fitting material or the mood of the installer. The HAELOK press tool generates form and restrained pipe joints, forming a physical cold forming of pipe and fitting.

It's as strong as welding - but the only mechanical alternative.

Your perfect fit!





Press Tool advantages:

- ➔ Industry's smallest press system
- ➔ One piece solution
- ➔ Fully automatic press process
- ➔ **Press time < 1 min**
- ➔ Ergonomic design, easy to handle and carry
- ➔ **Everything in one box**
- ➔ Reduced weight
- ➔ Various models:
The right tool for every job

The Haelok press tools, named PTO613, PT1228 and PT3060, feature a hard-anodised housing for ultimate durability and compact closing mechanism that will be almost maintenance-free. Our press-tool and hydraulic-unit is built, an industry first, as one easy unit.

The battery driven units are state-of-the-art and guarantee easy, fast and problem-free installation in every situation.

By changing the inlays, within seconds, we allow users to adapt the press tool to work with all diameters needed.

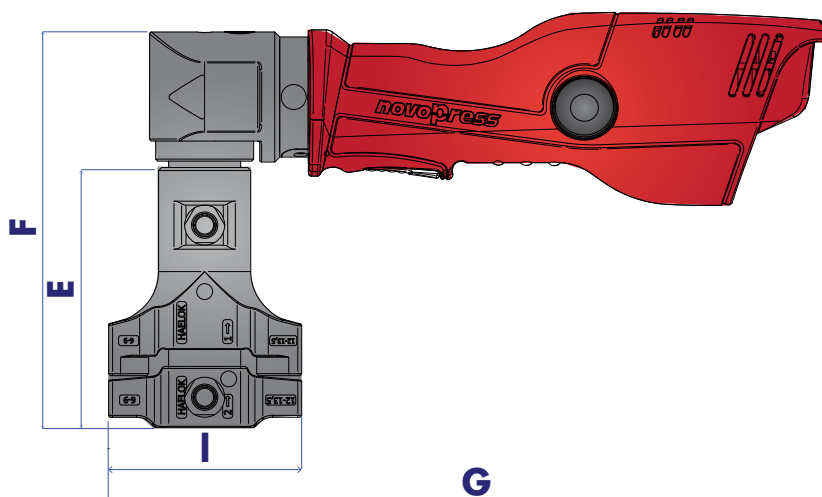

Press Tool Set PT 0613*

Measurements

Typ	Article No.	d Pipe diameter	E	F	G	I	Weight (g)	Press time (Ø, sec)
PT0613	HLK-61PS-0613	6 - 13	129.8	197.5	358.5	96.5	3600	5 - 10

*set includes: Press Tool, Hydraulic Unit, two Battery Packs with Charger, Transport Case

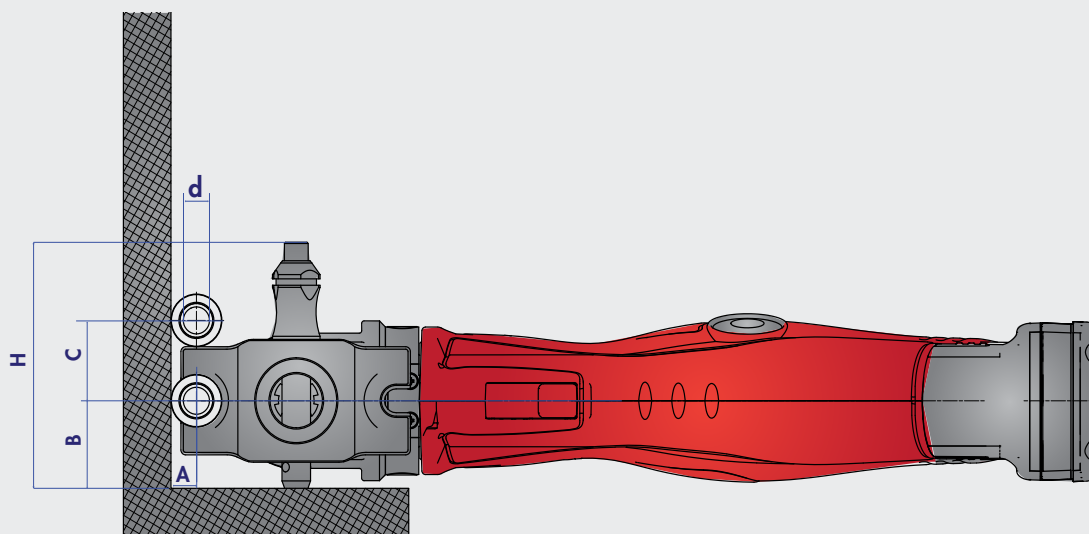

Typ	d Pipe diameter	A	B ¹⁾	C ²⁾	d	H
PT0613	6	7	40	28	6	112
	13	7	40	32	13	112

1) Minimum pipe to wall distances
2) Minimum pipe to pipe distance



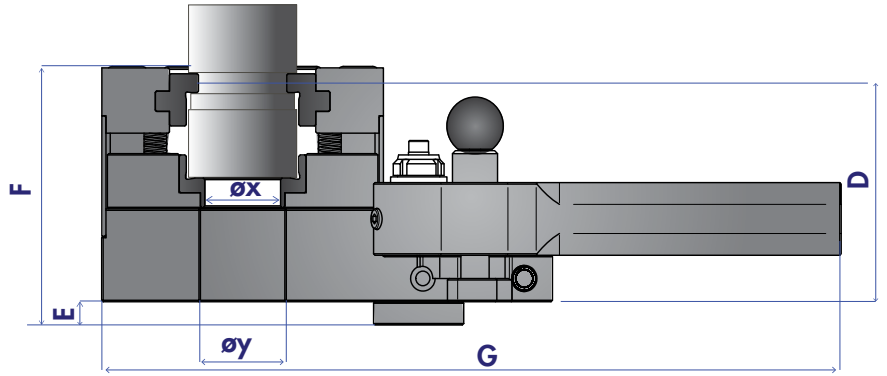

Press Tool Set PT 1228*

Measurements

Typ	Article No.	d Pipe diameter	D	E	F	G	øx	øy	Weight (g)	Press time (Ø, sec)
PT 1228	HLK-61PS-1228	12 28	75.25	8	89	262.5	variable according to inlay	30	6800	12 15

*set includes: Press Tool, Hydraulic Unit, two Battery Packs with Charger, Transport Case

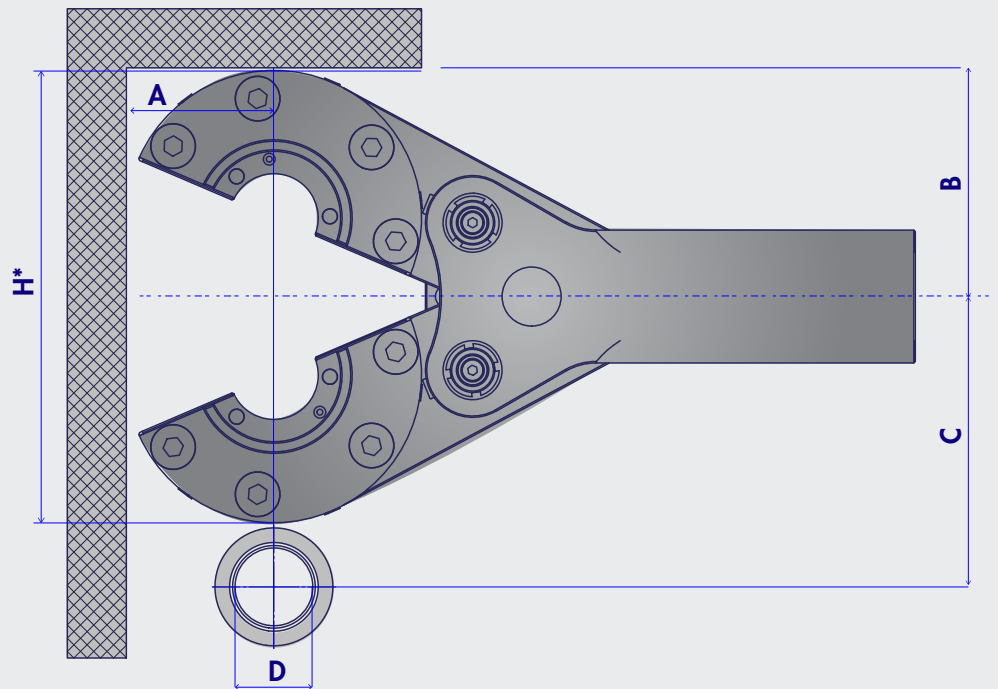

Typ	d Pipe diameter	A	B ¹⁾	C ²⁾	H*	H (closed tool)
PT 1228	12	67	100	114	153.2	134
	28	67	100	124		

1) Minimum pipe to pipe distance
2) Minimum pipe to wall distances

The Press tools set comes in a rugged transport case together with its attached Hydraulic Unit, two batterypacks and a charger.

Various inlays, according to the pipes in use, make the tool very flexible, and can be ordered based on your requirements.

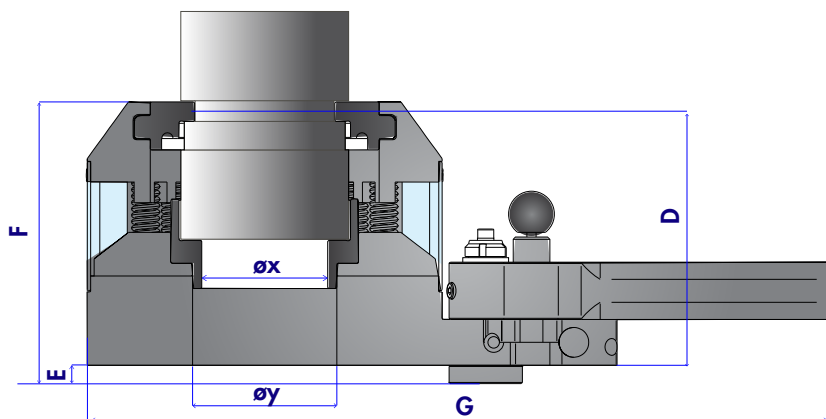

Press Tool Set PT 3060*

Measurements

Typ	Article No.	d Pipe diameter	D	E	F	G	øx	øy	Weight (g)	Press time (Ø, sec)
PT 3060	HLK-61PS-3060	30 60	110.75	8	128	324	variable according to inlay	63	8000	16 20

*set includes: Press Tool, Hydraulic Unit, two Battery Packs with Charger, Transport Case

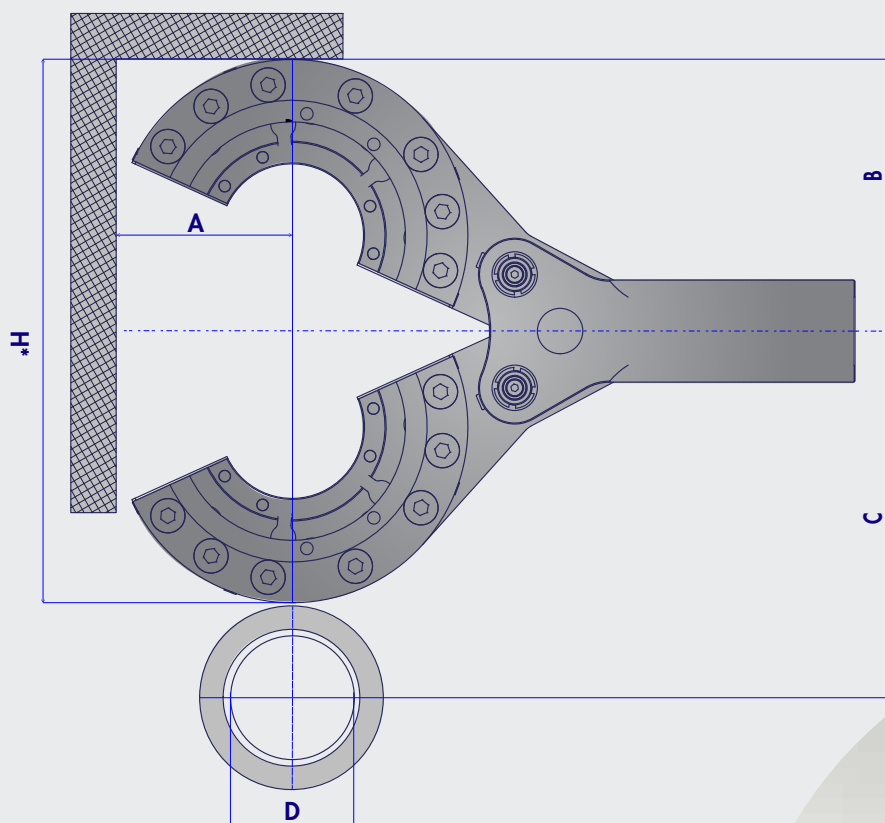

Typ	D Pipe diameter	A	B ¹⁾	C ²⁾	H*	H (closed tool)
PT 3060	30	80	110	140	239.4	160
	60.3	80	110	150		

1) Minimum pipe to wall distances
2) Minimum pipe to pipe distance

The Press tools set comes in a rugged transport case together with its attached Hydraulic Unit, two battery packs and a charger. Various inlays, according to the pipes in use, make the tool very flexible, and can be ordered based on your requirements.



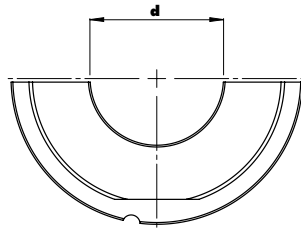

Inlays for Press Tool

Measurements

Tool	Article No.	suitable for following Haelok fittings	corresponding pipe diameters
PT1228	HLK-61PI-1213	12	12mm 1/4"
PT1228	HLK-61PI-1516	15 16	15mm 16mm
PT1228	HLK-61PI-1718	17 18	3/8" 18mm
PT1228	HLK-61PI-20	20	20mm
PT1228	HLK-61PI-2122	21 22	1/2" 22mm
PT1228	HLK-61PI-25	25	25mm
PT1228	HLK-61PI-26	26	3/4"
PT1228	HLK-61PI-28	28	28mm
PT3060	HLK-61PI-30	30	30mm
PT3060	HLK-61PI-33	33	1"
PT3060	HLK-61PI-35	35	35mm
PT3060	HLK-61PI-38	38	38mm
PT3060	HLK-61PI-42	42	1 1/4"
PT3060	HLK-61PI-48	48	1 1/2"
PT3060	HLK-61PI-54	54	54mm
PT3060	HLK-61PI-60	60	2"

All dimensions in millimeters, except specially marked
Errors and technical changes reserved

Please order your inlay set according to the fitting sizes used: An inlay set consists of four pieces that can be easily attached into the corresponding press tool and if not used can be stored safely in its corresponding place in the transport case.

Accessories

Product	Article No.	length	width	depth	Weight (g)
Transport Case for PT0613	HLK-61PC-0613	571	393	160	c1500
Transport Case for PT1228	HLK-61PC-1228	571	393	160	c1500
Transport Case for PT3060	HLK-61PC-3060	571	393	160	c1500
Battery 12 1,5Ah Li-ion	HLK-61BA-15				
Battery 12 3,0Ah Li-ion	HLK-61BA-30				
Battery Charging Unit	HLK-61BA-CH-EU				
Marking Tool	HLK-61MA-0660				



Installation support details

Minimum length of adapter piece for repair (L_{min})

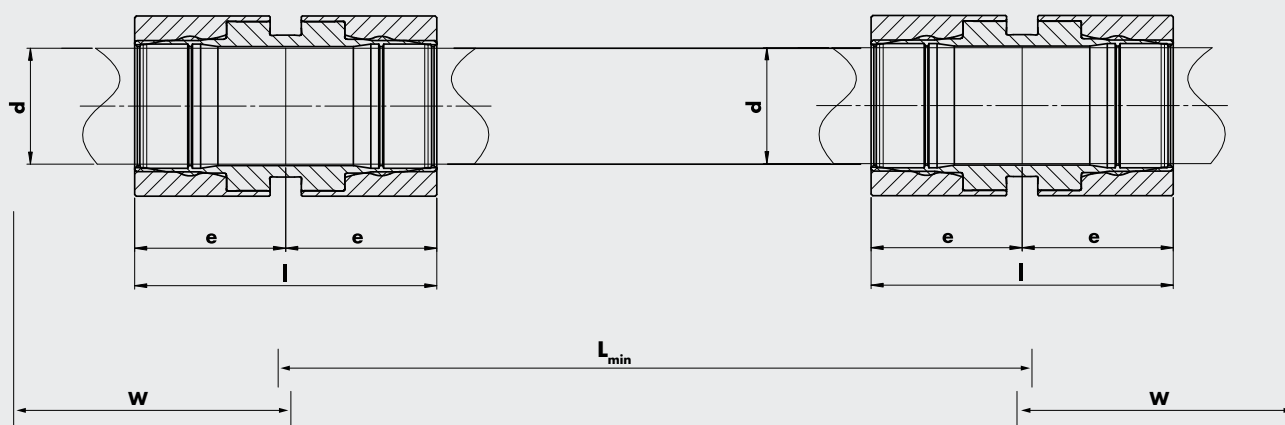

Press Tool	L_{min}	W	l	e
PT 0613	60	200	37	18.5
PT 1228	116	90	52	26
PT 3060	174	130	87	43.5

W= width of the tool in its state before pressing

All dimensions in millimeters, except specially marked
Errors and technical changes reserved

Minimum clearance for tool (W)

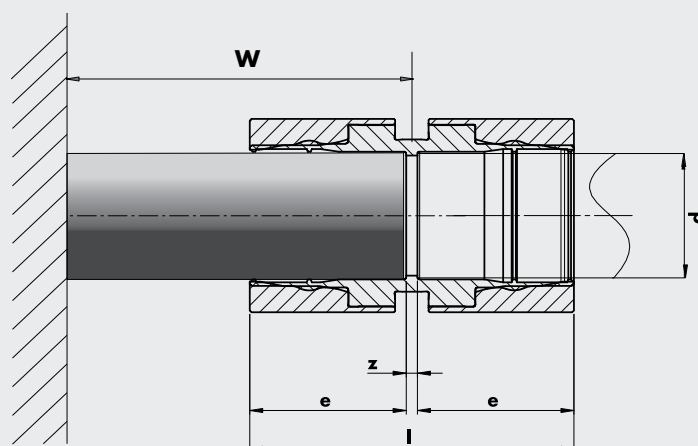

Press Tool	W	$l_{pressed}$	$l_{un-pressed}$	e	z
PT 0613	200	37	46	17	3
PT 1228	90	52	61	25	2
PT 3060	130	87	107	42	3

W= minimum stripping / wall clearance

All dimensions in millimeters, except specially marked
Errors and technical changes reserved

Installation and Handling of the Haelok press tool

Installation guide:

The hydraulic installation tool behind the world's strongest mechanical pipe connection, installs the HAELOK fitting in a few simple steps. Watch our installation movie at www.haelok.com and see how our system delivers everytime accurate, reliable and repeatable results, regardless of the fitting material or the mood of the installer. You get a perfect connection in minutes.

Disclaimer: Fittings must be installed without torsion and stress during installation. Only trained and instructed personal are allowed to work with HAELOK machines.



- 1. MEASURE** Check pipe dimension and wall thickness and compare your values with our tolerance page (p.9)



- 2. CUT** Cut the pipe perpendicular. If you use a preinsulated pipe, strip the insulation cover.



- 3. DEBURR GRIND** Clean the cut pipe inside and outside. Use sandpaper to remove loose rust, scratches and dirt.



- 4. MARK** Mark the pipe with our marking tool or at the end of the unpressed fitting for visual control after pressing is done.



- 5. INSERT** Insert pipe to the inner stop (middle) of the fitting.



- 6. ATTACH** Attach the press tool firmly over the connection you wish to make, so that the pulling fits into the groove of the fitting.



- 7. PRESS** Press the operation button on the battery unit until it stops automatically.



- 8. READY!** A perfect connection is created. A visual check on the compression is sufficient: Press ring is in line with the fittings body and you see the marking of the pipe. Your perfect fit!

your partner:



FLOWTEKNIK
SCANDINAVIA APS



RUGVÆNGET 19 C
2630 TAASTRUP
INFO@PGFLOWTEKNIK.DK
WWW.PGFLOWTEKNIK.DK

HAELOK AG | Josefstrasse 225 | 8005 Zurich | Switzerland
t: +41 43 501 4555 | f: +41 43 501 4551 | email: info@haelok.com
www.haelok.com

