



*The Right Connection®*

# 2014

## Dixon Quick Coupling



**Service • Solutions • Selection**



<p><b>PNEUMATIC</b> steel • brass</p>  <p><b>A-Series</b> <i>Astronautic</i> page 55</p>	<p><b>HYDRAULIC</b> steel</p>  <p><b>AG-Series</b> <i>Agricultural</i> page 79</p>	<p><b>PNEUMATIC</b> brass</p>  <p><b>BR-Series</b> <i>Rectus '21'</i> page 53</p>	<p><b>PNEUMATIC</b> steel • brass</p>  <p><b>CJ-Series</b> <i>CEN 320/410</i> page 31</p>	<p><b>HYDRAULIC</b> brass</p>  <p><b>CM-Series</b> <i>Mold Coolant</i> page 156</p>
<p><b>HYDRAULIC</b> steel</p>  <p><b>CVV-Series</b> <i>Euro-Threaded</i> page 137</p>	<p><b>PNEUMATIC</b> steel • brass • 303ss</p>  <p><b>DF-Series</b> <i>MIL-C-4109F</i> page 12</p>	<p><b>HYDRAULIC</b> steel • brass • 303ss</p>  <p><b>E-Series</b> <i>Straight-Thru</i> page 148</p>	<p><b>HYDRAULIC</b> steel</p>  <p><b>EA-Series</b> <i>Water Blast</i> page 154</p>	<p><b>HYDRAULIC</b> steel • brass • 303ss • 316ss</p>  <p><b>H &amp; H-BOP Series</b> <i>ISO7241-B</i> pages 60 &amp; 146</p>
<p><b>HYDRAULIC</b> steel • brass • 303ss</p>  <p><b>HS-Series</b> <i>ISO7241-B Steam</i> page 71</p>	<p><b>HYDRAULIC</b> steel • 316ss</p>  <p><b>HT &amp; HTE Series</b> <i>ISO16028</i> pages 102 &amp; 110</p>	<p><b>PNEUMATIC</b> steel • brass</p>  <p><b>J-Series</b> <i>Truflate</i> page 22</p>	<p><b>HYDRAULIC</b> steel</p>  <p><b>K-Series</b> <i>ISO7241-A</i> page 74</p>	<p><b>PNEUMATIC</b> steel • brass</p>  <p><b>L-Series</b> <i>Lincoln</i> page 37</p>
<p><b>PNEUMATIC</b> steel • brass</p>  <p><b>M-Series</b> <i>ARO 210-310</i> page 27</p>	<p><b>PNEUMATIC</b> steel • brass • 303ss</p>  <p><b>N-Series</b> <i>Bowes / Dixlock</i> page 41</p>	<p><b>PNEUMATIC</b> steel</p>  <p><b>NK-Series</b> <i>d panese Industrial</i> page 51</p>	<p><b>PNEUMATIC</b> steel • brass • 303ss</p>  <p><b>P-Series</b> <i>Thor / Dual-Lock</i> page 48</p>	<p><b>HYDRAULIC</b> steel</p>  <p><b>PD-Series</b> <i>ISO15171-1 Test</i> page 119</p>
<p><b>PNEUMATIC</b> brass</p>  <p><b>SCV-Series</b> <i>Pneumatic Safety</i> page 58</p>	<p><b>PNEUMATIC</b> steel • aluminum</p>  <p><b>SHD-Series</b> <i>Schrader</i> page 34</p>	<p><b>HYDRAULIC</b> steel • 316ss</p>  <p><b>ST-Series</b> <i>Snap-Tite '71'</i> page 113</p>	<p><b>HYDRAULIC</b> steel • 316ss</p>  <p><b>T-Series</b> <i>Enerpac Style</i> page 134</p>	<p><b>HYDRAULIC</b> steel</p>  <p><b>TR-Series</b> <i>TEMA Style</i> page 100</p>
<p><b>PNEUMATIC</b> steel • brass • 303ss</p>  <p><b>U-Series</b> <i>Universal Air</i> page 39</p>	<p><b>HYDRAULIC</b> steel • brass • 316ss</p>  <p><b>V-Series</b> <i>Snap-Tite 'H/IH'</i> page 83</p>	<p><b>HYDRAULIC</b> steel</p>  <p><b>VEP &amp; VEP-BOP Series</b> <i>Stucchi VEP</i> pages 121 &amp; 142</p>	<p><b>HYDRAULIC</b> steel • brass • 303ss</p>  <p><b>W-Series</b> <i>Wingstyle</i> page 124</p>	<p><b>HYDRAULIC</b> steel • 316ss</p>  <p><b>WS &amp; WS-BOP Series</b> <i>Snap-Tite '75'</i> pages 129 &amp; 144</p>

General Product Information

A-Series	AG-Series	BR-Series	CJ-Series	CM-Series	CVV-Series	DF-Series	E-Series	EA-Series	H-Series	HS-Series	HT-Series	J-Series	K-Series	L-Series	M-Series	N-Series	NK-Series	P-Series	PD-Series	SCV-Series	SHD-Series	ST-Series	T-Series	TR-Series	U-Series	V-Series	VEP-Series	W-Series	WS-Series	Main Multiplier	
55	79	53	31	146	134	12	138	144	60	71	102	22	74	37	27	41	51	48	116	58	34	110	131	100	39	83	118	121	125	Page	
	✓		✓	✓	✓	✓	✓	✓	✓	✓	✓	✓	✓	✓	✓	✓	✓	✓	✓	✓	✓	✓	✓	✓	✓	✓	✓	✓	✓	Manual	
✓	■	✓	✓	✓	✓	✓	✓	✓	✓	✓	✓	✓	✓	✓	✓	✓	✓	✓	✓	✓	✓	✓	✓	✓	✓	✓	✓	✓	✓	Automatic	
◆				◆		◆	◆	✓	◆	◆	✓	◆	◆			■						◆		✓		◆				Sleeve-Lock	
✓		✓		✓		✓	✓		✓	✓	✓	✓	✓	✓	✓		✓		✓				✓	✓	✓	✓	✓	✓	✓	1/8"	
✓	✓		✓	✓	✓	✓	✓		✓	✓	✓	✓	✓	✓	✓		✓		✓	✓	✓	✓	✓	✓	✓	✓	✓	✓	✓	1/4"	
✓	✓			✓	✓	✓	✓	✓	✓	✓	✓	✓	✓	✓	✓	✓	✓	✓	✓	✓	✓	✓	✓	✓	✓	✓	✓	✓	✓	3/8"	
				✓	✓	✓	✓	✓	✓	✓	✓	✓	✓	✓	✓	✓	✓	✓	✓	✓	✓	✓	✓	✓	✓	✓	✓	✓	✓	1/2"	
	✓				✓	✓	✓		✓	✓	✓	✓	✓	✓	✓	✓	✓	✓	✓	✓	✓	✓	✓	✓	✓	✓	✓	✓	✓	5/8"	
	✓				✓	✓	✓		✓	✓	✓	✓	✓	✓	✓	✓	✓	✓	✓	✓	✓	✓	✓	✓	✓	✓	✓	✓	✓	3/4"	
	✓				✓	✓	✓		✓	✓	✓	✓	✓	✓	✓	✓	✓	✓	✓	✓	✓	✓	✓	✓	✓	✓	✓	✓	✓	1"	
				✓	✓	✓	✓		✓	✓	✓	✓	✓	✓	✓	✓	✓	✓	✓	✓	✓	✓	✓	✓	✓	✓	✓	✓	✓	1-1/4"	
					✓	✓	✓		✓	✓	✓	✓	✓	✓	✓	✓	✓	✓	✓	✓	✓	✓	✓	✓	✓	✓	✓	✓	✓	1-1/2"	
							✓		✓	✓	✓	✓	✓	✓	✓	✓	✓	✓	✓	✓	✓	✓	✓	✓	✓	✓	✓	✓	✓	2"	
	✓				✓				✓	✓		✓	✓				✓						✓	✓				✓	✓	2-1/2"	
✓		✓	✓	✓	✓	✓			✓			✓			✓	✓	✓			✓	✓		✓	✓	✓	✓		✓	✓	Poppet	
✓	✓			✓		✓					✓				✓	✓	✓			✓	✓		✓	✓	✓	✓		✓	✓	Tube	
	✓										✓				✓	✓	✓			✓	✓		✓							Ball	
✓		✓	✓	✓		✓					✓				✓	✓	✓			✓	✓		✓				✓	✓	✓	No-Spill	
✓	✓			✓					✓			✓			✓	✓	✓			✓	✓		✓							Single Shutoff	
◆	◆			✓		◆	✓	✓	◆	◆		◆	◆			✓	✓			✓	✓		◆							Double Shutoff	
■	✓		■	■	✓	■	■	✓	■	■	✓	■	■	■	■	■	✓	✓	✓	✓	✓	✓	■	■	■	■	■	■	■	Unvalved	
✓		✓	✓	✓		✓	✓		■	✓		■		■	■	■	✓	✓	✓	✓	✓	✓	✓	■	✓	■	✓	✓	✓	Steel	
						■	■		■	■		■		■	■	■	■	■	■	■	■	■	■	■	■	■	■	■	■	■	Brass
									■	■		■		■	■	■	■	■	■	■	■	■	■	■	■	■	■	■	■	■	303 SS
									■	■		■		■	■	■	■	■	■	■	■	■	■	■	■	■	■	■	■	■	316 SS
✓	✓	✓	✓	✓		✓	✓	✓	✓	✓	✓	✓	✓	✓	✓	✓	✓	✓	✓	✓	✓	✓	✓	✓	✓	✓	✓	✓	✓	✓	Balls
					✓						✓						✓					✓					✓	✓	✓	Threaded	
																	✓				✓									Other	
✓	✓	✓	✓	✓	✓	✓	✓	✓	✓	✓	✓	✓	✓	✓	✓	✓	✓	✓	✓	✓	✓	✓	✓	✓	✓	✓	✓	✓	✓	✓	Nitrile
							◆	◆	◆				◆									◆				◆				◆	Cold Nitrile
							◆	◆	◆		◆		◆									◆				◆				◆	Fuel Nitrile
							◆	◆	◆		◆		◆									◆				◆				◆	FDA Nitrile
◆							◆	◆	◆		◆		◆			◆						◆	◆			◆				◆	FKM
							◆	◆	◆		◆		◆									◆	◆			◆				◆	FDA FKM
◆							◆	◆	◆		◆		◆									◆				◆				◆	EPDM
							◆	◆	◆		◆		◆									◆				◆				◆	FDA EPDM
							◆	◆	◆		◆		◆									◆				◆				◆	Steam EPDM
							◆	◆	◆		◆		◆									◆				◆				◆	Aflas®
							◆	◆	◆		◆		◆									◆				◆				◆	Neoprene
				✓			◆	◆	◆		◆		◆									◆				◆				◆	Silicone
							◆	◆	◆		◆		◆									◆				◆				◆	Fluorosilicone
							◆	◆	◆		◆		◆									◆	✓			◆				◆	Urethane
							◆	◆	◆		◆		◆									◆				◆				◆	Kalrez®
✓	✓	✓	✓	✓	✓	✓	✓	✓	✓	✓	✓	✓	✓	✓	✓	✓	✓	✓	✓	✓	✓	✓	✓	✓	✓	✓	✓	✓	✓	✓	PTFE/Silicone
✓		✓	✓	■	✓	✓	✓	✓	■	✓	■	✓	✓	✓	✓	✓	✓	✓	✓	✓	✓	✓	✓	✓	✓	✓	✓	✓	✓	✓	NPTF Female
	■	✓	✓		✓	■	✓		✓	✓	✓	✓	✓	✓	✓	✓	✓	✓	✓	✓	✓	✓	✓	✓	✓	✓	✓	✓	✓	✓	NPTF Male
	✓				■				■		✓	✓	✓								■		■	✓		■	✓	✓	✓	✓	BSP Female
									■		✓	✓	✓									✓				■	✓	✓	✓	✓	BSP Male
									■		✓	✓	✓									✓				✓	✓	✓	■	Female ORB	
										■	■	■	■									■									Male ORB
										■	■	■	■									■									JIC Male
										■	■	■	■									■									JIC Bulkhead
✓		✓	✓	■	✓	✓	✓				✓	✓	✓			✓	✓	✓	✓	✓	✓	✓	✓	✓	✓	✓	✓	✓	✓	✓	Hose Barb
✓			■	■	■	■	■				■	■	■			■	■	■	■	■	■	■	■	■	■	■	■	■	■	■	Push-Loc
✓																														✓	Reusable

Standard Program Offering ✓

Available As Standard On Some Items ■

Optional ◆

## Be Safe When Selecting Quick Couplings!



All quick disconnect couplings should be viewed as potential hazards that can cause property damage, personal injury or even death if used or installed improperly! Improper use includes selecting a product unsuitable for your application, installing or using the product incorrectly and ignoring signs of imminent failure or mis-use. Failure may result in explosive propulsion of components, rapid expulsion of hazardous media, and failure or unintentional movement of a fluid powered component.

### Proper Selection of Quick Disconnect Couplings

The very properties that make a compressed media useful in almost every area of modern life can also make them dangerous when mishandled. Dixon quick disconnect couplings have been carefully engineered to meet specific industry requirements while maintaining abundant safety margins. If quick disconnect couplings are not used in the correct applications or are incorrectly applied, accidents and downtime can result. It is up to the end user to inform the distributor of the application and pressures involved when ordering quick disconnect couplings and it is up to the distributor to supply the right coupling for the application.

The use of S.T.A.M.P.E.D. will help in the proper selection of quick disconnect coupling products. When in doubt, Dixon Quick Coupling will provide information, including test results (if available), coupling recommendations and other data to help resolve quick disconnect coupling related issues.

### S.T.A.M.P.E.D. Questions and Selection Process

#### Size

Couplings should be selected to handle the flow and pressure requirements of the system. Excessive pressure drop will result in restricted flow, slower actuation, higher fluid velocity, heat generation and eventually a breakdown of fluids, seals and components.

1. What size coupler is required?
2. What is the maximum allowable pressure drop for the application?
3. Are there any size restrictions due to a 'tight-spot' installation?

#### Temperature

Media and ambient temperatures must be limited to the specific operating parameters of the selected sealing materials. Excessive cold will reduce sealing capability while excessive heat can cause the premature breakdown of body and valve seals.

1. What is the media/fluid temperature?
2. What is the ambient temperature?
3. Are there any 'flash' heat or fire sources near the connection?

#### Application

Quick coupling interchangeability is a key issue that needs to be closely reviewed. There are several instances where non-interchangeable couplers and nipples may connect. This is very dangerous and these couplings should never be pressurized. Be sure to match like series couplers and nipples!

1. Is an industry interchange coupler required?
2. What are the functional requirements of the coupling?
3. Have there been any problems with other couplings in this application?

#### Media

Quick disconnect couplings are available with a variety of body materials and seal options. Exposure to harsh and corrosive operating environments may reduce service life. Several quick couplings spill fluid upon disconnection which may be a safety concern!

1. Which seal and body materials are compatible with the system fluid?
2. Is air inclusion, system contamination or fluid loss a concern?
3. Is this fluid dangerous to the operator?

#### Pressure

During the selection process, the published working pressure of the coupling must be equal to or greater than the maximum system pressure. Surge pressures in a fluid power system, higher than the rated pressure, will shorten the service life of the coupling.

1. Is the pressure 'Static' or 'Dynamic'?
2. What is the maximum operating pressure required for the application?
3. Are there any pressure spikes in the system?

#### Ends

Many end configurations are available and each one has specific operating parameters. For example, the working pressure of couplings utilizing Hose Barb or Collar Hose Barb end connections may be dramatically reduced. In if doubt, test under controlled conditions for suitability to the application.

1. What end configuration and size is required? (Male Threaded, Female Threaded, or Hose Barb)
2. Does the chosen end configuration support the application parameters and system pressure?
3. What is the ideal valving configuration? (Single Shut-off, Double Shut-off, or Unvalved)

#### Details

Forgotten or missed application details can cause a failure if not properly addressed! Be meticulous in the assessment of your application to ensure that all parameters are considered in the selection of the proper quick disconnect coupling.

1. Are there any side-load, vibration or swivelling problems associated with the application?
2. Does the coupling require a safety sleeve-lock mechanism?
3. Are there any environmental concerns that need to be addressed?

## Be Safe When Selecting Quick Couplings!

**!** Quick disconnect couplings can fail without warning! Prior to the operation of quick coupling products, be sure to inspect and replace worn out fittings and safety devices. If a leak is detected during operation, release the pressure from the circuit before investigating the cause of the fluid leak. Do not use your fingers or skin to check for leaks, high pressure leaks of fluids can easily penetrate the skin and can cause serious injury or death.

### Safe Quick Coupling Practices



1. Always wipe the coupling cavities and faces clean before connecting a coupling.
2. Connect coupling before installation to ensure that it works properly.
3. Always check the body seals before connecting a coupling.
4. Shut-off power source before connecting a coupling.
5. Always install a safety check valve on a pneumatic line and/or compressor.
6. Always use a safety cable on large air lines (½" lines and larger).
7. Always use a whip hose on hydraulic or air tools.
8. Use dust caps or plugs when couplings are not in use.
9. If the locking sleeve is inoperable, check the safety lock.
10. Wear eye protection while connecting or disconnecting a coupling.

### Unsafe Quick Coupling Practices



1. Never hit coupling valves to release trapped pressure.
2. Never leave couplings in the path of moving equipment.
3. Never use couplings near a welder, flash heat, or fire / flame sources.
4. Never use API modified sealants or over apply PTFE tape during installation.
5. Use care if you must install quick couplings onto black iron pipe.
6. Never hit a coupling sleeve with a hammer or blunt object.
7. Never overtighten a coupling connection.
8. Never rotate a quick disconnect coupling under pressure.
9. Do not overpressurize quick disconnect couplings.
10. Never use a hose with a quick disconnect coupling to lift a tool.

### OSHA Regulations Ensure Operator Safety



Safety Cables



Safety Check Valves

#### Standard - 29 CFR, 1926.302 (partial):

(b)(1) Pneumatic power tools shall be secured to the hose or whip by some positive means to prevent the tool from becoming accidentally disconnected.

(b)(2) Safety Clips or retainers shall be securely installed and maintained on pneumatic impact (percussion) tools to prevent attachments from being accidentally expelled.

(b)(4) Compressed air shall not be used for cleaning purposes except where reduced to 30 PSI and then only with effective chip guarding and personal protective equipment which meets the requirements of Subpart E of this part. The 30 PSI requirement does not apply for concrete form, mill scale and similar cleaning purposes.

(b)(5) The manufacturer's safe operating pressure for hoses, pipes, valves, filters and other fittings shall not be exceeded.

(b)(6) The use of hoses for hoisting or lowering tools shall not be permitted.

(b)(7) All hoses exceeding ½" inside diameter shall have a safety device at the source of supply or branch line to reduce pressure in case of hose failure.

#### Standard - 29 CFR, 1926.603 (partial):

(a)(9) Steam hose leading to a steam hammer or jet pipe shall be securely attached to the hammer with an adequate length of at least ¼" diameter chain or cable to prevent whipping in the event the joint at the hammer is broken. Air hammer hoses shall be provided with the same protection as required for steam lines.

(a)(10) Safety chains, or equivalent means, shall be provided for each hose connection to prevent the line from thrashing around in case the coupling becomes disconnected.

## Male / Female Pipe (NPTF) Thread Identification

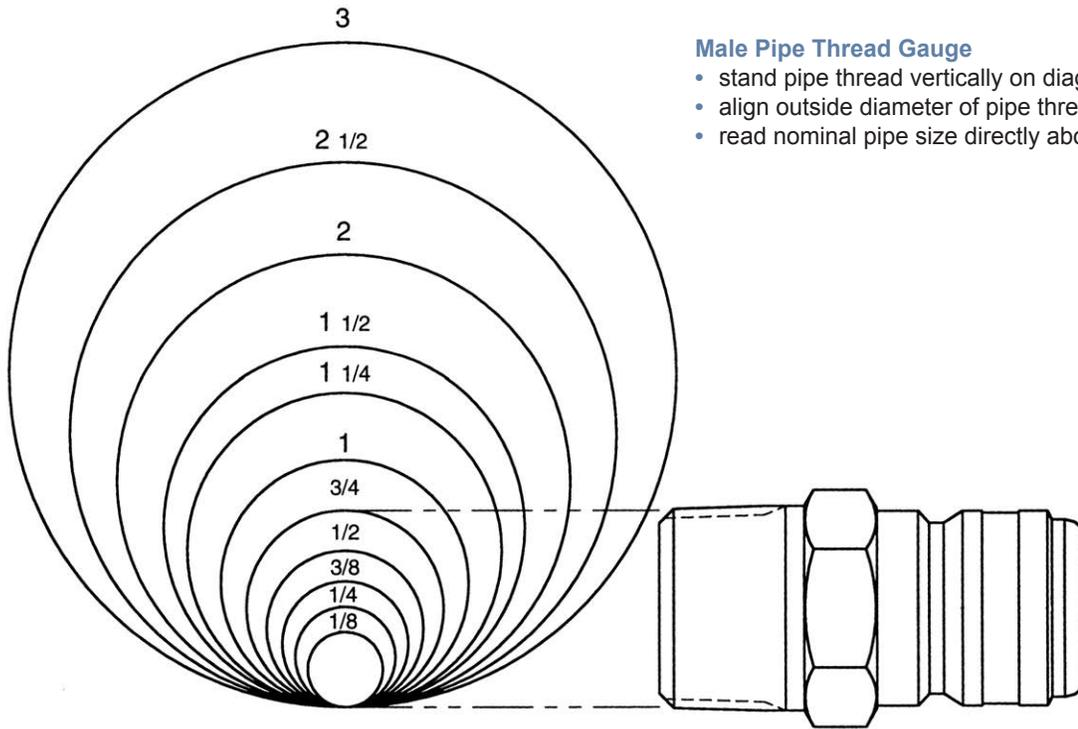

### Male Pipe Thread Gauge

- stand pipe thread vertically on diagram
- align outside diameter of pipe thread with matching circle
- read nominal pipe size directly above circle

Example: 3/4 male pipe  
(Dixon end size = 6)

### Female Pipe Thread Gauge

- hold pipe thread against scale on edge of page
- align one side of pipe thread with illustration base line
- read nominal pipe size directly from scale

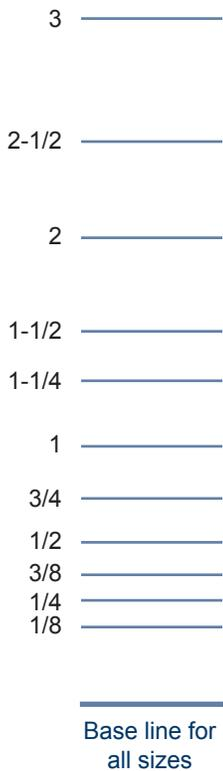

Example: 3/4 female pipe  
(Dixon end size = 6)

Nominal Pipe Size (inches)	Dixon End Size	Nominal Thread Size (inches)	Nominal Pipe Size (inches)
1/8	1	1/8 - 27	0.41
1/4	2	1/4 - 18	0.54
3/8	3	3/8 - 18	0.68
1/2	4	1/2 - 14	0.84
3/4	6	3/4 - 14	1.05
1	8	1-11-1/2	1.32
1-1/4	10	1-1/4 - 11-1/2	1.66
1-1/2	12	1-1/2 - 11-1/2	1.90
2	16	2 - 11-1/2	2.38
2-1/2	20	2-1/2 - 8	2.88
3	24	3 - 8	3.50

## Glossary of Quick Coupling Terms

**Absolute Pressure:** A measure of pressure having its zero point at atmospheric pressure. For example, the sum of atmospheric and gauge pressure would be absolute pressure (PSIA). For vacuum, it is expressed in inches of mercury.

**Accidental Disconnection:** Disconnection of a coupling while in operation due to failure of the coupling mechanism (a.k.a. unintentional disconnection).

**Accumulator:** A container in which fluid is stored under pressure as a source of reserve fluid power.

**Aeration:** Air in a fluid

**Air Inclusion:** The air forced into the system during the connection of a quick disconnect coupling.

**Atmospheric Pressure:** Pressure exerted by the atmosphere at any specific location. Sea level pressure is approximately 14.7 PSI.

**Backpressure:** Refers to pressure existing on the discharge side of a system.

**Bar:** An international standard unit of pressure equal to 100,000 Pascals, approximately 14.5 PSI.

**Blind-Mate:** A coupling that can be automatically connected without human intervention and without visibility.

**Break-Away:** Automatic disconnection of a coupling when an axial separation force is applied.

**Brinelling:** Dimples or grooves worn into the shoulder of a male half by locking balls in the female half. This is terminology stemming from a test that is done to evaluate the hardness of metals. Swedish metallurgist, Johan August Brinell (1849-1925), developed a hardness test that measures the relative hardness of metals and alloys by forcing a 10 mm hard steel ball into a test piece with a 3000 kg load for 30 seconds. After completion of the test, the surface area of the resulting indentation was measured.

**Burst Pressure:** The pressure at which a device loses the capability to retain pressure.

**Case Hardening:** Hardening the entire surface of a low carbon steel to a specific depth.

**Cavitation:** A localized gaseous condition within a liquid stream which occurs where the pressure is reduced to the vapor pressure.

**Charge Pressure:** The pressure at which replenishing fluid is forced into the hydraulic system (above atmospheric pressure).

**Check Valve:** A valve which permits flow of media in one direction only.

**Cold Flow:** Continued deformation under load.

**Connect Under Pressure:** The ability to connect coupling halves with internal line pressure applied to either both sides or one side.

**Contamination:** Any material foreign to a media that has a harmful effect on its performance in a system.

**Coupling, Female Half:** a.k.a. coupler, socket, receiver

**Coupling, Male Half:** a.k.a. nipple, plug, adapter

**Coupling, Quick Disconnect:** A component which can quickly join or separate a fluid line without the use of tools or special devices.

**Differential Pressure:** (DP) The difference in pressure between any two points of a system or a component, also known as Delta-P or pressure drop.

**Drybreak Coupling:** A coupling that allows connection and disconnection without spillage or air inclusion (a.k.a. flush face, flat face, no-spill)

**Double-Acting Sleeve:** Permits push-to-connect and pull-to-connect convenience when female half is mounted on the sleeve.

**Dust Cap:** Dust or dirt repelling enclosure for the nipple.

**Dust Plug:** Dust or dirt repelling enclosure for the coupler.

**Dynamic Pressure:** Pressure that, once it is released, is able to be immediately replenished.

**Flow Checking:** Occurs when a valve closes during flow conditions, such as when quickly lowering a heavy implement (a.k.a. check off, back checking, lock-up).

**Flush Position (valve):** A no-spill valve that allows connection and disconnection without spillage or air inclusion. (a.k.a. flush face, drybreak, no-spill).

**Force to Connect:** Axial and/or rotational force required to make a complete connection.

**Force to Disconnect:** The reverse of the above.

**GPM:** Acronym for Gallons Per Minute, a measure of flow.

**Leakage:** The media that is unintentionally released from a coupling due to component failure or retention weaknesses.

**LPM:** Acronym for Liters Per Minute, a measure of flow.

**Induction Hardening:** Hardening of a localized area of medium or high carbon steel.

**Operating Pressure:** The pressure at which a system is operated (a.k.a. working pressure).

**Peak Pressure:** Maximum momentary pressure encountered in the operation of a component (a.k.a. pressure spike, surge pressure)

**Pressure Cap:** A cap which incorporates a seal capable of withstanding the rated pressures on the male half.

**Pressure Impulse Test:** Subjecting a component to a specified pressure at a specific rate of increase or decrease for a specified time limit and cycle.

**Proof Pressure:** The nondestructive test pressure in excess of the maximum rated operating pressure, generally 1.5 times the standard operating pressure.

**PSI:** Acronym for Pounds Per Square Inch, a measure of pressure.

**Push to Connect:** Locking arrangement which permits one handed connection by pushing the nipple into the coupler (a.k.a. automatic sleeve, automatic collar, automatic connection).

**Rotation:** The act of spinning the coupler and nipple in opposite directions in a continuous manner beyond 360°.

**Single Acting Sleeve:** Making connection requires manually pulling female sleeve back, inserting the male tip (a.k.a. semi-auto sleeve, manual sleeve)

**Sleeve Lock:** A coupling arrangement that provides an additional lock which must be actuated before locking sleeve can be retracted (a.k.a. pin-lock, locking sleeve).

**Spillage:** The fluid released from the system due to disconnection of a quick disconnect coupling. This is the fluid trapped between the mating seal and the valve seal of the coupling halves.

**Static Pressure:** Pressure that, once released, is not able to be immediately replenished.

**Surge Flow:** A rapid increase in fluid flow.

**Swivel:** The act of spinning the coupler and nipple in opposite directions to a degree that is less than 360°.

**Thermal Build-Up:** Pressure caused by expansion of a media due to heat from an external source such as sunlight (a.k.a. thermal expansion).

**Trapped Pressure:** Pressurized fluid trapped behind a closed coupling valve.

**Turbulence:** Is the condition where the media does not move smoothly parallel to the flow direction. Turbulent flow is caused by abrupt changes in direction, changes of cross-section, or by high velocity. The result is increased friction, which generates heat, decreases operating pressure and wastes power.

**Twist Lock:** A locking arrangement which requires a rotational actuation to unlock the mating halves.

**Vacuum:** Partially or completely exhausted of air, gas or other media to create a negative pressure. Theoretically, a perfect vacuum would be measured as 30 inches of mercury, but that is unattainable. The true perfect vacuum is 29.7 inches of mercury.

## Be Safe When Installing Quick Couplings!

**!** All quick disconnect couplings should be viewed as potential hazards that can cause property damage, personal injury or even death if used or installed improperly!

Couplings should be installed in a location that will allow easy operation of the coupling and accessibility for all necessary installation tools. Care should be given to consider operator safety, especially if spillage upon disconnection could result in fluid ignition or skin and eye irritation.

Only apply wrenches to the hex or machined wrench flats that are provided for assembly purposes, nowhere else. Never clamp on the sleeve of the coupler or the nose of the nipple, this will cause distortion and/or damage.

Finally, always test quick coupling installations before putting into operation by pressurizing the unit to 150% of the working pressure in an enclosed/protective environment.

### Installation of Tapered Thread Connections (NPTF)

The seal for NPTF threads is created by the metal-to-metal contact between the roots and crests of the male and female threads. Too much PTFE tape, or pairing liquid sealant with PTFE tape may cause distortion, poor thread engagement, or cracking of the coupling during assembly.

The total number of tapered threads engaged should be between 3½ to 6. Any number of threads outside this range may indicate either under or over tightening of the joint or out of tolerance threads. After assembly of a NPTF thread connection, always proof-test the connection before operating the system. If the joint proves to be inadequately tightened during proof-pressure testing, tighten it further in 1/8 turn increments until a reliable seal is attained (do not exceed 3 T.F.F.T!)



Apply 1½ to 2 wraps of PTFE tape, starting one or two threads from the lead edge, in a clockwise direction. For 316 stainless steel, be sure to use stainless grade tape.

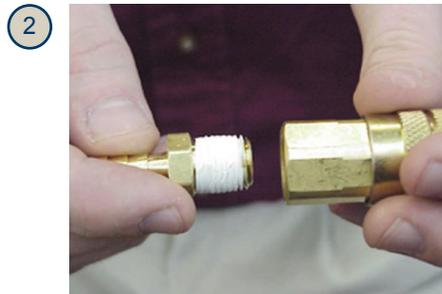

Check threads to make sure there is no obvious damage on either half and that tape is properly installed. Align male and female threaded connections and carefully begin threading the two halves together.



Finger tighten the connection and create a reference mark on the hex of the hose end/adaptor and the coupling. This mark will help identify the number of revolutions during the next step in the procedure.



With even and smooth force applied, wrench tighten according to the 'Turns From Finger Tight' (T.F.F.T.) values listed below. **DO NOT OVERTIGHTEN!**

SAE Size	NPTF Thread Size	T.F.F.T
-4	1/4" - 18	2
-6	3/8" - 18	2
-8	1/2" - 14	2
-12	3/4" - 14	1.5
-16	1" - 11 1/2	1.5



## Be Safe When Installing Quick Couplings!

### Installation of O-Ring Boss (ORB) Connections

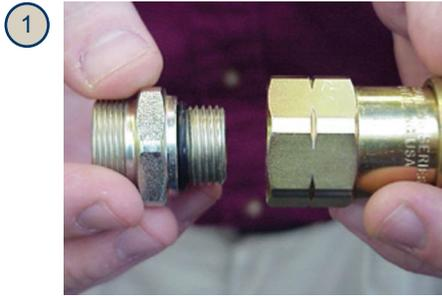

1  
Lightly lubricate the O-Ring on the adapter and thread it into the coupling. Hand-tighten, ensuring that the O-Ring is not pinched during installation.

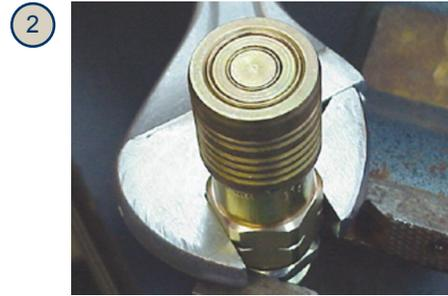

2  
Wrench tighten the connection to the appropriate torque specification, as shown in the chart below.

SAE Size	Thread Size	Torque Nm	Torque lb-ft
-4	7/16"-20	18-20	13-15
-6	9/16"-18	29-33	22-24
-8	3/4"-16	49-53	40-43
-10	7/8"-14	59-64	43-48
-12	1-1/16"-12	93-102	68-75
-16	1-5/16"-12	151-166	112-123
-20	1-5/8"-12	198-218	146-161
-24	1-7/8"-12	209-231	154-170

### Installation of 37° Flare (JIC) Connections



1  
Lightly lubricate the flare on the adapter and thread it into the coupling. Hand-tighten, ensuring that the flare is seated correctly during installation.



2  
Wrench tighten the connection to the appropriate torque specification, as shown in the chart below.

SAE Size	Thread Size	Torque Nm	Torque lb-ft
-4	7/16"-20	15-16	11-12
-6	9/16"-18	24-28	18-20
-8	3/4"-16	49-53	36-39
-10	7/8"-14	77-85	57-63
-12	1-1/16"-12	107-119	79-88
-16	1-5/16"-12	147-154	108-113
-20	1-5/8"-12	172-181	127-133
-24	1-7/8"-12	215-226	158-167

## Be Safe When Installing Quick Couplings!

### Installation of Reusable Hose Couplings

1

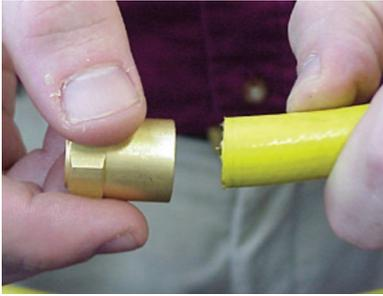

Trim the end of the hose as square as possible.

2



Install ferrule by slipping it onto the end of the hose and twisting it counter-clockwise.

3



Apply lubricant sparingly to the reusable barb before inserting it into the ferrule.

4



Turn the reusable fitting into the ferrule until coupling is seated against ferrule.

### Installation of Push-Loc Hose Connections

1

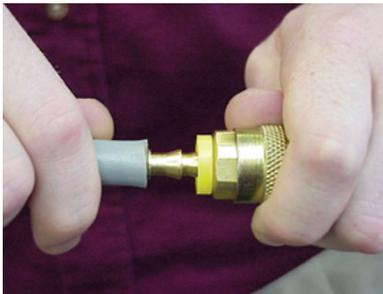

Trim hose end squarely and lubricate the Push-Loc barb and hose. Insert Push-Loc barb into the hose until first barb is inside the hose.

2



Place the end of the fitting against a flat object and grip the hose one inch from end. Push with a steady force until the end of hose is covered by the yellow plastic cap.

## Be Safe When Installing Quick Couplings!

### Installation of 'N' and 'P' Series Ferruled Hose Barbs

Note that the charts below are to be used only as a guide and not as a steadfast rule for every coupling application. In some instances, alternative dies and crimped dimensions must be employed. Hoses, as well as couplings, react differently during crimping. This is due to the fact that there are variances in hose constructions for hose with similar dimensions. Some variables are: textile braid versus wire braid, hardwall versus softwall, presence or lack of internal spiral wire as well as differences in hose covers. In addition, the outer diameter of the hose tends to fluctuate from end to end and production lot to production lot. With this in mind, we suggest that you measure the hose OD and maintain accurate records for each coupling application.

Hose ID	Fractional Hose OD	Decimal Hose OD	'N' Crimp Length	'N' Crimp OD $\pm$ .005	'P' Crimp Length	'P' Crimp OD $\pm$ .005
1/2"	54/64"	0.844	1-1/8"	0.917	1-1/4"	0.917
1/2"	55/64"	0.859	1-1/8"	0.929	1-1/4"	0.929
1/2"	56/64"	0.875	1-1/8"	0.942	1-1/4"	0.942
1/2"	57/64"	0.891	1-1/8"	0.954	1-1/4"	0.954
1/2"	58/64"	0.906	1-1/8"	0.987	1-1/4"	0.987
1/2"	59/64"	0.922	1-1/8"	0.980	1-1/4"	0.980
1/2"	60/64"	0.938	1-1/8"	0.992	1-1/4"	0.992
1/2"	61/64"	0.953	1-1/8"	1.005	1-1/4"	1.005
1/2"	62/64"	0.969	1-1/8"	1.018	1-1/4"	1.018
1/2"	63/64"	0.984	1-1/8"	1.030	1-1/4"	1.030
1/2"	1"	1.000	1-1/8"	1.043	1-1/4"	1.043
1/2"	1-1/64"	1.016	1-1/8"	1.056	1-1/4"	1.056
1/2"	1-2/64"	1.031	1-1/8"	1.068	1-1/4"	1.068
3/4"	1-10/64"	1.156	1-1/4"	1.220	1-1/4"	1.220
3/4"	1-11/64"	1.171	1-1/4"	1.235	1-1/4"	1.235
3/4"	1-12/64"	1.187	1-1/4"	1.244	1-1/4"	1.244
3/4"	1-13/64"	1.203	1-1/4"	1.260	1-1/4"	1.260
3/4"	1-14/64"	1.218	1-1/4"	1.270	1-1/4"	1.270
3/4"	1-15/64"	1.234	1-1/4"	1.285	1-1/4"	1.285
3/4"	1-16/64"	1.250	1-1/4"	1.295	1-1/4"	1.295
3/4"	1-17/64"	1.265	1-1/4"	1.310	1-1/4"	1.310
3/4"	1-18/64"	1.281	1-1/4"	1.320	1-1/4"	1.320
3/4"	1-19/64"	1.296	1-1/4"	1.335	1-1/4"	1.335
3/4"	1-20/64"	1.312	1-1/4"	1.345	1-1/4"	1.345
3/4"	1-21/64"	1.328	1-1/4"	1.360	1-1/4"	1.360
3/4"	1-22/64"	1.343	1-1/4"	1.370	1-1/4"	1.370

### Installation of Light Duty Ferrules

Hose ID	Fractional Hose OD	Decimal Hose OD	Dixon Part #	Ferrule Thickness	SMOD	% Compression	Crimp Diameter
1/2"	54/64"	0.8438	CCF0906	0.024	0.513	15	0.853
1/2"	55/64"	0.8594	CCF0906	0.024	0.513	15	0.866
1/2"	56/64"	0.8750	CCF0906	0.024	0.513	15	0.880
3/4"	1-5/64"	1.0781	CCF1120	0.030	0.763	20	1.086
3/4"	1-6/64"	1.0938	CCF1120	0.030	0.763	20	1.098
3/4"	1-7/64"	1.1094	CCF1149	0.030	0.763	20	1.111
3/4"	1-8/64"	1.1250	CCF1149	0.030	0.763	20	1.123
3/4"	1-9/64"	1.1406	CCF1190	0.025	0.763	20	1.126
3/4"	1-10/64"	1.1563	CCF1190	0.025	0.763	20	1.138
3/4"	1-11/64"	1.1719	CCF1218	0.025	0.763	20	1.151
3/4"	1-12/64"	1.1875	CCF1218	0.025	0.763	20	1.163
3/4"	1-13/64"	1.2031	CCF1246	0.030	0.763	20	1.186
3/4"	1-14/64"	1.2188	CCF1246	0.030	0.763	20	1.198
3/4"	1-15/64"	1.2344	CCF1277	0.030	0.763	20	1.211
3/4"	1-16/64"	1.2500	CCF1277	0.030	0.763	20	1.223
1"	1-25/64"	1.3906	CCF1430	0.030	1.007	20	1.380
1"	1-26/64"	1.4063	CCF1430	0.030	1.007	20	1.392
1"	1-27/64"	1.4219	CCF1469	0.030	1.007	20	1.405
1"	1-28/64"	1.4375	CCF1469	0.030	1.007	20	1.417
1"	1-29/64"	1.4531	CCF1500	0.030	1.007	20	1.430
1"	1-30/64"	1.4688	CCF1500	0.030	1.007	20	1.442
1"	1-31/64"	1.4844	CCF1530	0.030	1.007	20	1.455
1"	1-32/64"	1.5000	CCF1530	0.030	1.007	20	1.467

## Installation of Pneumatic Couplings

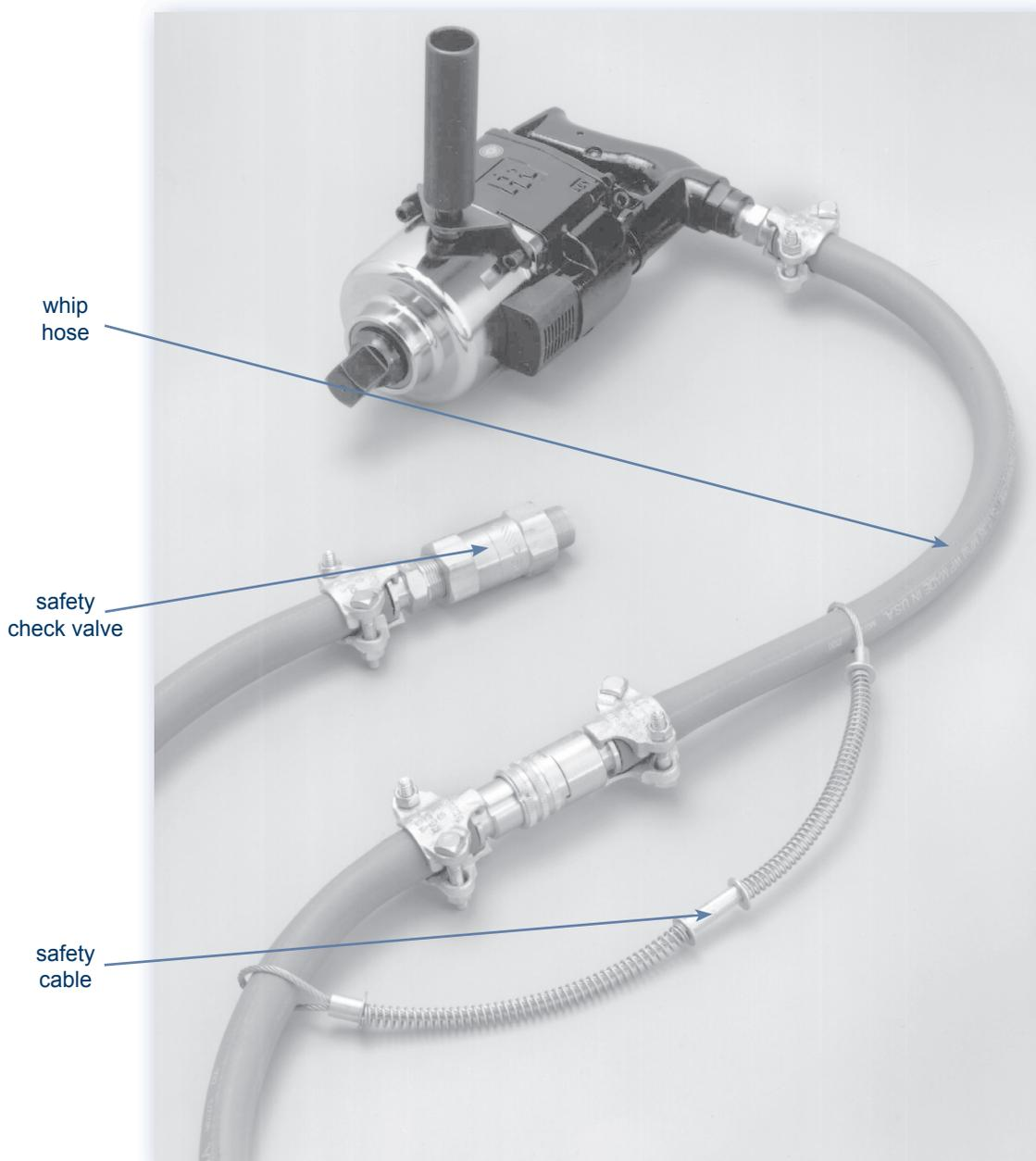

It is important to be safe when installing quick disconnect couplings into a pneumatic circuit. Never install a pneumatic coupling directly into an air tool, use a piece of hose that is at least 18" long, between the tool and the coupling, to prevent damage to the coupling. To protect the operator, safety devices, such as a safety check valve and safety cable should be installed in case there is a hose or coupling failure.

## Fluid Compatibility Guide

The following chart is intended only as a guide in selecting various elastomers and metals for use with fluids to be conveyed through Dixon Quick Disconnect Couplings. This list does not guarantee suitability for a particular application. Final selection is dependent upon operating pressure, fluid and ambient temperature, concentration of media, duration of exposure, environmental conditions, and frequency of connect and disconnect.



Material	Prefix Code	Trade Name	Availability	Range °C	Range °F
Buna-N	Standard	Nitrile	Stock	-40°C to +121°C	-40°F to +250°F
Buna-N (MIL-H-5606 Fluids)	M-	Nitrile	3-5 Days	-54°C to +135°C	-65°F to +275°F
Buna-N (Hydrocarbon Fuels)	JF-	Nitrile	3-5 Days	-54°C to +71°C	-65°F to +160°F
Fluorocarbon Rubber	F-	FKM	3-5 Days	-29°C to +204°C	-20°F to +400°F
Ethyl Propylene Diene Monomer	P-	EPDM	5-7 Days	-54°C to +149°C	-65°F to +300°F
Neoprene	E-	Neoprene	7-10 Days	-43°C to +149°C	-45°F to +300°F
Silicone	S-	Silicone	7-10 Days	-73°C to +177°C	-100°F to +350°F
Fluorosilicone (FVMQ)	FS-	Silastic®	7-10 Days	-60°C to +180°C	-76°F to +376°F
Urethane	U-	Urethane	7-10 Days	-40°C to +82°C	-40°F to +180°F
Polyurethane	UP-	Polyurethane	7-10 Days	-54°C to +100°C	-65°F to 212°F
PTFE Encapsulated Silicone	TS-	TES	7-10 Days	-73°C to +204°C	-100°F to +400°F
PTFE Encapsulated Fluorocarbon	TF-	TEF	7-10 Days	-73°C to +204°C	-100°F to +400°F
Perfluoroelastomer (Compound 1)	K4-	Kalrez® 4079	5-7 Days	-20°C to +316°C	-4°F to +600°F
Perfluoroelastomer (Compound 2)	K6-	Kalrez® 6375	7-10 Days	-20°C to +275°C	-4°F to +525°F
Perfluoroelastomer (Compound 3)	K7-	Kalrez® 7075	7-10 Days	-20°C to +327°C	-4°F to +620°F
Fluoroelastomer	H-	Aflas®	7-10 Days	-5°C to +204°C	+23°F to +400°F

Media Name	Suggested Seal	Media Name	Suggested Seal	Media Name	Suggested Seal
Acetic Anhydride	P-	Freon, General	E-	Mineral Spirits	Standard
Acetone	P-	Ferric Hydroxide	Standard	Nickel Acetate	P-
Acetylene	Standard	Formaldehyde (50%)	P-	Nickel Suphate	P-
Air (To 200°F)	Standard	Fuel Oils, General	Standard	Nitrogen, Gas	Standard
Air (Above 200°F)	F-	Gasoline	Standard	Nitrous Oxide	Standard
Alcohol, Ethyl	P-	Glycerine (Glycerol)	Standard	Octane	F-
Alcohol, Methyl	Standard	Glycols	P-	Oleum Spirits	Standard
Alkalies, General	Standard	Helium	Standard	OS45 and OS45-1	F-
Ammonia, Aqueous	P-	Heptane	Standard	Oxygen, Non-Breathing	F-
Ammonia, Gas	P-	Hexane	Standard	Paint Thinner	F-
Ammonia, Anhydrous	P-	Hydraulic Oil, Aircraft	Standard	Paraffin	Standard
Ammonia, Hydroxide	P-	Hydraulic Oil, Petroleum	Standard	Peanut Oil	Standard
Aroclor	F-	Hydraulic Oil, Phosphate	P-	Pentane	Standard
Benzene (Benzol)	F-	Hydrogen Gas	Standard	Perchloroethylene	F-
Bleach Solutions	P-	Hydrolube	Standard	Phosphoric Acid (100%)	P-
Brake Fluid, Non-Petro	P-	Isobutyl Alcohol	P-	Photographic Solutions	P-
Bromine Gas	F-	Isopropyl Alcohol	F-	Potassium Acetate	P-
Butane	Standard	Jet Fuel (to 160°F)	JF-	Propane	Standard
Butyl Alcohol	Standard	Jet Fuel (above 160°F)	F-	Propylene	F-
Carbon Dioxide, Dry	Standard	Kerosene	Standard	Propylene Glycol	Standard
Carbon Dioxide, Wet	Standard	Lindol	P-	Silicone Oil	Nitrile
Carbon Monoxide	Standard	LP Gas	Standard	Steam, General Service	H-
Carbon Tetrachloride	F-	Magnesium Hydroxide	F-	Stoddard Solvent	Standard
Cellulube	P-	Methane	Standard	Sulphuric Acid (100%)	F-
Creosote	F-	Methanol	Standard	Toluene	F-
Crude Oil	F-	Methyl Bromide	F-	Transmission Fluid (A)	Standard
Cutting Oil	Standard	Methyl Ethyl Ketone (MEK)	P-	Trichloroethylene	F-
Diesel Fuel	Standard	MIL-F-81912 (JP-9)	P-	Turpentine	Standard
Diester Lubricants	F-	MIL-H-5606	M1-	Vegetable Oil	Standard
Ethane	Standard	MIL-H-5806	Standard	Water	Standard
Ethanol	Standard	MIL-H-6083	Standard	Water, Distilled	Standard
Ethyl Chloride	Standard	MIL-H-7083	Standard	Water, Dionized	Standard
Ethylene Glycol	P-	Mineral Oils	Standard	Water, Sea	P-

# DF-Series Pneumatic Couplings

## Interchange Data:

- Parker 20-Series Manual Interchange (F-Series)
- Parker 30-Series Automatic Interchange (D-Series)
- Foster 3, 4, 5, and 6 Series
- Hansen 1000, 400, 500 (F-Series)
- Hansen 3000, 4000, 5000, 6000 (D-Series)

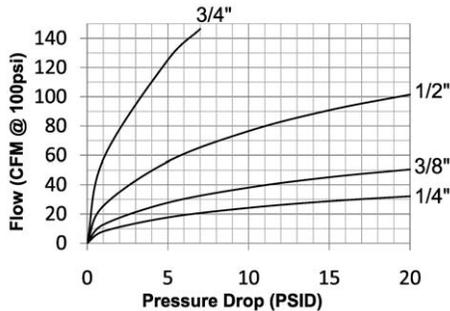

## Materials:

- Machined components are manufactured using solid steel, brass, or 303 stainless steel bar stock.
- Stainless steel balls, retaining rings, and springs maximize corrosion resistance and extend service life.
- Steel componentry is plated using ROHS Compliant Trivalent Chrome.
- Automatic couplers constructed of brass with steel tubular valve as standard (3/8" to 3/4" couplers have steel prong valves).
- 1/4" manual couplers constructed of brass with steel sleeve and steel tubular valve as standard.
- 3/8" and 1/2" manual couplers constructed of steel as standard with steel tubular valve.

## Seal Components:

- Nitrile (Buna-N) seals are standard, providing a temperature range of -40°F to +250°F (-40°C to +121°C).

## Rated Pressure Charts:

Body Size	D-Series Automatic Industrial Interchange (Connected)															
	Brass Coupler/Steel Plug				Brass Coupler/Plug				Steel Coupler/Plug				303 Stainless Coupler/Plug			
	Max. Working		Burst		Max. Working		Burst		Max. Working		Burst		Max. Working		Burst	
	PSI	Bar	PSI	Bar	PSI	Bar	PSI	Bar	PSI	Bar	PSI	Bar	PSI	Bar	PSI	Bar
1/4"	500	35	16,000	1,100	300	20	16,000	1,100	-	-	-	-	500	35	26,000	1,795
3/8"	500	35	15,500	1,070	300	20	14,500	1,000	-	-	-	-	500	35	25,500	1,760
1/2"	500	35	14,000	965	300	20	10,500	725	-	-	-	-	500	35	20,500	1,415
3/4"	500	35	10,000	670	-	-	-	-	-	-	-	-	-	-	-	-

Body Size	F-Series Manual Industrial Interchange (Connected)															
	Brass Coupler/Steel Plug				Brass Coupler/Plug				Steel Coupler/Plug				303 Stainless Coupler/Plug			
	Max. Working		Burst		Max. Working		Burst		Max. Working		Burst		Max. Working		Burst	
	PSI	Bar	PSI	Bar	PSI	Bar	PSI	Bar	PSI	Bar	PSI	Bar	PSI	Bar	PSI	Bar
1/4"	500	35	9,000	620	300	20	8,500	586	500	35	6,500	448	500	35	11,500	795
3/8"	500	35	11,500	790	300	20	10,000	690	500	35	19,500	1,345	500	35	20,500	1,415
1/2"	-	-	-	-	-	-	-	-	500	35	15,500	1,070	500	35	15,000	1,035

## Technical Specifications:

Body Size	Interchange Standards				Functional Parameters				
	U.S. Military	U.S. Government	International Standards	ANSI/NFPA Standards	Locking Ball Quantity	Air Inclusion	Fluid Loss	Vacuum Rating	Flow ΔP=15 PSI
1/4"	MIL-C-4109F	A-A-59439	ISO6150B	T3.20.14-1990	6	N/A	N/A	N/R	27 CFM
3/8"	-	-	ISO6150B	T3.20.14-1990	6	N/A	N/A	N/R	45 CFM
1/2"	MIL-C-4109F	A-A-59439	ISO6150B	T3.20.14-1990	6	N/A	N/A	N/R	91 CFM
3/4"	-	-	-	T3.20.14-1990	9	N/A	N/A	N/R	200 CFM

## List Price Seal Option Adders:

Body Size	Seal Options				Valve Options					Sleeve Options						Treatments				
	FKM		EPDM		Unvalved		Brass		303SS		Flanged		Sleeve-Lock		Brass		303SS		Oxy-Clean	
	Pre	Add \$	Pre	Add \$	Suf	Add \$	Suf	Add \$	Suf	Add \$	Suf	Add \$	Suf	Add \$	Suf	Add \$	Suf	Add \$	Suf	Add \$
1/4"	F-	\$2.00	P-	\$2.50	-E	-\$0.65	-BV	\$0.90	-SV	\$0.90	-FS	N/A	-LS	\$5.00	-BS	\$2.60	-XS	\$7.60	-C1	\$12.00
3/8"	F-	3.10	P-	N/A	-E	-2.70	-BV	2.90	-SV	2.90	-FS	N/A	-LS	6.00	-BS	N/A	-XS	15.50	-C1	12.00
1/2"	F-	4.40	P-	N/A	-E	-3.00	-BV	3.50	-SV	3.50	-FS	N/A	-LS	7.50	-BS	N/A	-XS	20.00	-C1	14.00
3/4"	F-	N/A	P-	N/A	-E	-3.80	-BV	N/A	-SV	N/A	-FS	N/A	-LS	8.90	-BS	std.	-XS	N/A	-C1	16.00

## DF-Series Pneumatic Couplings

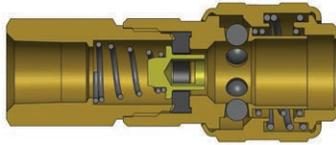

Body Size	D-Series Automatic Industrial Interchange Coupler (Female Threads)											
	Part Detail			List Price	Length		Maximum OD		Hex Inch	Weight Lb	Package Qty	
	Part Number	Threads	Material		Inch	mm	Inch	mm			Bag	Box
1/4"	2DF1-B	1/8" - 27 NPTF	brass	\$15.79	2.19	55.6	0.99	25.1	11/16"	0.30	10	100
1/4"	2DF2-B	1/4" - 18 NPTF	brass	13.17	2.38	60.5	0.99	25.1	11/16"	0.28	10	100
1/4"	2DF2-S	1/4" - 18 NPTF	303 stainless	69.28	2.38	60.5	0.99	25.1	11/16"	0.29	10	100
1/4"	2DBF2-B	1/4" - 19 BSPP	brass	13.17	2.38	60.5	0.99	25.1	11/16"	0.28	10	100
1/4"	2DF3-B	3/8" - 18 NPTF	brass	15.54	2.38	60.5	0.99	25.1	11/16"	0.30	10	100
1/4"	2DF3-S	3/8" - 18 NPTF	303 stainless	82.79	2.38	60.5	0.99	25.1	13/16"	0.30	10	100
1/4"	2DBF3-B	3/8" - 19 BSPP	brass	15.54	2.38	60.5	0.99	25.1	13/16"	0.30	10	100
3/8"	3DF2-B	1/4" - 18 NPTF	brass	26.78	2.50	63.5	1.26	32.0	7/8"	0.43	10	50
3/8"	3DF3-B	3/8" - 18 NPTF	brass	25.73	2.60	66.0	1.26	32.0	7/8"	0.42	10	50
3/8"	3DF3-S	3/8" - 18 NPTF	303 stainless	103.50	2.60	66.0	1.26	32.0	7/8"	0.42	10	50
3/8"	3DBF3-B	3/8" - 19 BSPP	brass	26.78	2.60	66.0	1.26	32.0	7/8"	0.42	10	50
3/8"	3DF4-B	1/2" - 14 NPTF	brass	28.07	2.80	71.1	1.26	32.0	1"	0.46	10	50
1/2"	4DF3-B	3/8" - 18 NPTF	brass	35.62	3.10	78.7	1.38	35.1	1-1/16"	0.56	5	30
1/2"	4DF4-B	1/2" - 14 NPTF	brass	36.26	3.30	83.8	1.38	35.1	1-1/16"	0.66	5	30
1/2"	4DF4-S	1/2" - 14 NPTF	303 stainless	139.62	3.30	83.8	1.38	35.1	1-1/16"	0.67	5	30
1/2"	4DBF4-B	1/2" - 14 BSPP	brass	36.26	3.30	83.8	1.38	35.1	1-1/16"	0.66	5	30
1/2"	4DF6-B	3/4" - 14 NPTF	brass	36.26	3.40	86.4	1.38	35.1	1-3/16"	0.73	5	30
3/4"	6DF4-B	1/2" - 14 NPTF	brass	56.14	2.95	74.9	1.73	43.9	1-5/16"	1.10	-	20
3/4"	6DF6-B	3/4" - 14 NPTF	brass	56.14	2.99	75.9	1.73	43.9	1-5/16"	1.10	-	20
3/4"	6DF8-B	1" - 11 1/2 NPTF	brass	56.14	3.18	80.8	1.73	43.9	1-1/2"	1.24	-	20

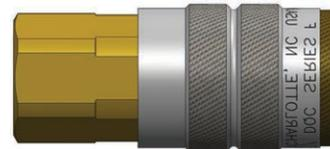
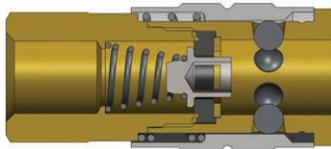

Body Size	F-Series Manual Industrial Interchange Coupler (Female Threads)											
	Part Detail			List Price	Length		Maximum OD		Hex Inch	Weight Lb	Package Qty	
	Part Number	Threads	Material		Inch	mm	Inch	mm			Bag	Box
1/4"	2FF1-B	1/8" - 27 NPTF	brass	\$11.46	1.91	48.6	0.93	23.5	3/4"	0.20	10	100
1/4"	2FBF1-B	1/8" - 28 BSPP	brass	11.46	1.91	48.6	0.93	23.5	3/4"	0.20	10	100
1/4"	2FF2	1/4" - 18 NPTF	steel	11.91	2.07	52.6	0.93	23.5	3/4"	0.20	10	100
1/4"	2FF2-B	1/4" - 18 NPTF	brass	8.53	2.07	52.6	0.93	23.5	3/4"	0.19	10	100
1/4"	2FF2-S	1/4" - 18 NPTF	303 stainless	49.12	2.07	52.6	0.93	23.5	3/4"	0.20	10	100
1/4"	2FBF2-B	1/4" - 19 BSPP	brass	11.46	2.07	52.6	0.93	23.5	3/4"	0.19	10	100
1/4"	2FF3-B	3/8" - 18 NPTF	brass	11.13	2.10	53.4	0.93	23.5	13/16"	0.19	10	100
1/4"	2FF3-S	3/8" - 18 NPTF	303 stainless	54.38	2.10	53.4	0.93	23.5	13/16"	0.18	10	100
1/4"	2FBF3-B	3/8" - 19 BSPP	brass	11.46	2.13	54.2	0.93	23.5	13/16"	0.19	10	100
3/8"	3FF2	1/4" - 18 NPTF	steel	23.39	2.41	61.2	1.13	28.6	7/8"	0.30	10	50
3/8"	3FF3	3/8" - 18 NPTF	steel	18.13	2.41	61.2	1.13	28.6	7/8"	0.32	10	50
3/8"	3FF3-S	3/8" - 18 NPTF	303 stainless	85.38	2.41	61.2	1.13	28.6	7/8"	0.32	10	50
3/8"	3FBF3	3/8" - 19 BSPP	steel	23.39	2.42	61.5	1.13	28.6	7/8"	0.32	10	50
3/8"	3FF4	1/2" - 14 NPTF	steel	27.48	2.63	66.9	1.13	28.6	1"	0.34	10	50
1/2"	4FF3	3/8" - 18 NPTF	steel	30.99	2.85	72.5	1.24	31.4	1"	0.46	5	30
1/2"	4FF4	1/2" - 14 NPTF	steel	22.93	3.06	77.8	1.24	31.4	1"	0.56	5	30
1/2"	4FF4-S	1/2" - 14 NPTF	303 stainless	107.59	3.06	77.8	1.24	31.4	1"	0.56	5	30
1/2"	4FBF4	1/2" - 14 BSPP	steel	30.99	3.09	78.4	1.24	31.4	1"	0.56	5	30
1/2"	4FF6	3/4" - 14 NPTF	steel	31.58	3.15	79.9	1.24	31.4	1-3/16"	0.63	5	30

## DF-Series Pneumatic Couplings

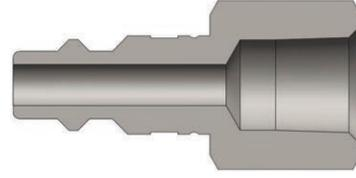

Body Size	DF-Series Industrial Interchange Nipple (Female Threads)											
	Part Detail			List Price	Length		Maximum OD		Hex Inch	Weight Lb	Package Qty	
	Part Number	Threads	Material		Inch	mm	Inch	mm			Bag	Box
1/4"	D2F1	1/8" - 27 NPTF	steel	\$3.45	1.44	36.6	0.65	16.5	9/16"	0.03	10	100
1/4"	D2F2	1/4" - 18 NPTF	steel	2.16	1.66	42.2	0.79	20.1	11/16"	0.03	10	100
1/4"	D2F2-B	1/4" - 18 NPTF	brass	3.41	1.66	42.2	0.79	20.1	11/16"	0.05	10	100
1/4"	D2F2-S	1/4" - 18 NPTF	303 stainless	11.58	1.66	42.2	0.79	20.1	11/16"	0.05	10	100
1/4"	D2BF2	1/4" - 19 BSPP	steel	3.55	1.66	42.2	0.79	20.1	11/16"	0.03	10	100
1/4"	D2F3	3/8" - 18 NPTF	steel	3.63	1.66	42.2	1.01	25.7	7/8"	0.08	10	100
1/4"	D2F3-B	3/8" - 18 NPTF	brass	5.23	1.66	42.2	1.01	25.7	7/8"	0.08	10	100
1/4"	D2F3-S	3/8" - 18 NPTF	303 stainless	12.58	1.66	42.2	1.01	25.7	7/8"	0.08	10	100
1/4"	D2BF3	3/8" - 19 BSPP	steel	4.93	1.66	42.2	1.01	25.7	7/8"	0.08	10	100
3/8"	D3F2	1/4" - 18 NPTF	steel	4.97	1.78	45.2	0.79	20.1	11/16"	0.06	10	50
3/8"	D3F3	3/8" - 18 NPTF	steel	4.33	1.78	45.2	1.01	25.7	7/8"	0.09	10	50
3/8"	D3F3-B	3/8" - 18 NPTF	brass	6.82	1.78	45.2	1.01	25.7	7/8"	0.10	10	50
3/8"	D3F3-S	3/8" - 18 NPTF	303 stainless	26.32	1.78	45.2	1.01	25.7	7/8"	0.09	10	50
3/8"	D3BF3	3/8" - 19 BSPP	steel	4.97	1.78	45.2	1.01	25.7	7/8"	0.09	10	50
3/8"	D3F4	1/2" - 14 NPTF	steel	7.89	1.94	49.3	1.16	29.5	1"	0.13	10	50
1/2"	D4F3	3/8" - 18 NPTF	steel	7.60	2.10	53.3	1.01	25.7	7/8"	0.12	10	50
1/2"	D4F4	1/2" - 14 NPTF	steel	7.31	2.27	57.7	1.16	29.5	1"	0.17	10	50
1/2"	D4F4-B	1/2" - 14 NPTF	brass	8.87	2.27	57.7	1.16	29.5	1"	0.19	10	50
1/2"	D4F4-S	1/2" - 14 NPTF	303 stainless	28.65	2.27	57.7	1.16	29.5	1"	0.17	10	50
1/2"	D4BF4	1/2" - 14 BSPP	steel	7.60	2.27	57.7	1.16	29.5	1"	0.17	10	50
1/2"	D4F6	3/4" - 14 NPTF	steel	12.86	2.30	58.4	1.37	34.8	1-3/16"	0.26	10	50
1/2"	D4F6-B	3/4" - 14 NPTF	brass	14.89	2.30	58.4	1.37	34.8	1-3/16"	0.26	10	50
3/4"	D6F4	1/2" - 14 NPTF	steel	15.05	2.22	56.4	1.52	38.6	1-5/16"	0.23	5	20
3/4"	D6F6	3/4" - 14 NPTF	steel	15.94	2.22	56.4	1.52	38.6	1-5/16"	0.34	5	20
3/4"	D6F8	1" - 11 1/2 NPTF	steel	25.28	2.41	61.2	1.80	45.7	1-9/16"	0.47	5	20

### DF Series Pneumatic Profile

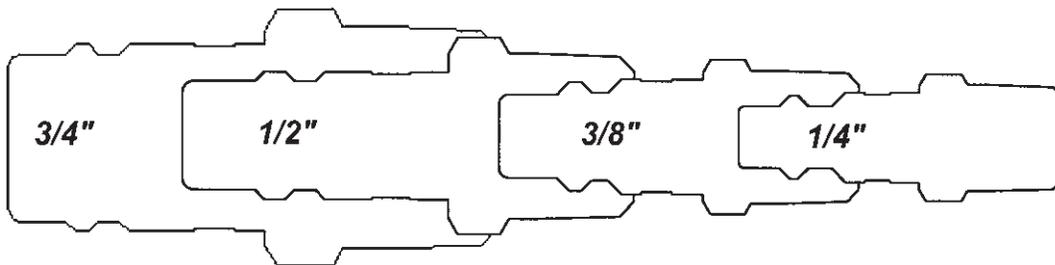



## DF-Series Pneumatic Couplings

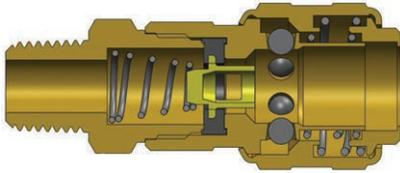

Body Size	D-Series Automatic Industrial Interchange Coupler (Male Threads)											
	Part Detail			List Price	Length		Maximum OD		Hex Inch	Weight Lb	Package Qty	
	Part Number	Threads	Material		Inch	mm	Inch	mm			Bag	Box
1/4"	2DM1-B	1/8" - 27 NPTF	brass	<b>\$15.79</b>	2.21	56.1	0.98	24.9	11/16"	0.27	10	100
1/4"	2DM2-B	1/4" - 18 NPTF	brass	<b>13.17</b>	2.34	59.4	0.98	24.9	11/16"	0.28	10	100
1/4"	2DM2-S	1/4" - 18 NPTF	303 stainless	<b>62.58</b>	2.34	59.4	0.98	24.9	11/16"	0.29	10	100
1/4"	2DBM2-B	1/4" - 19 BSPT	brass	<b>13.17</b>	2.34	59.4	0.98	24.9	11/16"	0.28	10	100
1/4"	2DM3-B	3/8" - 18 NPTF	brass	<b>15.54</b>	2.36	59.9	0.98	24.9	11/16"	0.28	10	100
1/4"	2DM3-S	3/8" - 18 NPTF	303 stainless	<b>81.32</b>	2.36	59.9	0.98	24.9	11/16"	0.28	10	100
1/4"	2DBM3-B	3/8" - 19 BSPT	brass	<b>15.54</b>	2.36	59.9	0.98	24.9	11/16"	0.28	10	100
3/8"	3DM2-B	1/4" - 18 NPTF	brass	<b>26.78</b>	2.59	65.8	1.18	30.0	7/8"	0.36	10	50
3/8"	3DM3-B	3/8" - 18 NPTF	brass	<b>25.73</b>	2.73	69.3	1.18	30.0	7/8"	0.39	10	50
3/8"	3DM3-S	3/8" - 18 NPTF	303 stainless	<b>100.44</b>	2.73	69.3	1.18	30.0	7/8"	0.39	10	50
3/8"	3DBM3-B	3/8" - 19 BSPT	brass	<b>26.03</b>	2.73	69.3	1.18	30.0	7/8"	0.39	10	50
3/8"	3DM4-B	1/2" - 14 NPTF	brass	<b>27.21</b>	2.94	74.7	1.18	30.0	7/8"	0.41	10	50
1/2"	4DM3-B	3/8" - 18 NPTF	brass	<b>33.99</b>	3.13	79.5	1.34	34.0	1-1/16"	0.58	5	30
1/2"	4DM4-B	1/2" - 14 NPTF	brass	<b>33.06</b>	3.17	80.5	1.34	34.0	1-1/16"	0.61	5	30
1/2"	4DM4-S	1/2" - 14 NPTF	303 stainless	<b>132.09</b>	3.17	80.5	1.34	34.0	1-1/16"	0.62	5	30
1/2"	4DBM4-B	1/2" - 14 BSPT	brass	<b>33.99</b>	3.17	80.5	1.34	34.0	1-1/16"	0.61	5	30
1/2"	4DM6-B	3/4" - 14 NPTF	brass	<b>34.89</b>	3.23	82.0	1.34	34.0	1-1/16"	0.67	5	30
3/4"	6DM4-B	1/2" - 14 NPTF	brass	<b>56.14</b>	2.95	74.9	1.90	48.3	1-3/16"	0.89	-	20
3/4"	6DM6-B	3/4" - 14 NPTF	brass	<b>56.14</b>	2.95	74.9	1.90	48.3	1-5/16"	0.91	-	20
3/4"	6DM8-B	1" - 11 1/2 NPTF	brass	<b>56.14</b>	3.12	79.2	1.90	48.3	1-9/16"	0.99	-	20

It is important to be safe when installing quick disconnect couplings into a pneumatic circuit. Never install a pneumatic coupling directly into an air tool, use a piece of hose that is at least 18" long, between the tool and the coupling, to prevent damage to the coupling. To protect the operator, safety devices, such as a safety check valve and safety cable should be installed in case there is a hose or coupling failure.



## DF-Series Pneumatic Couplings

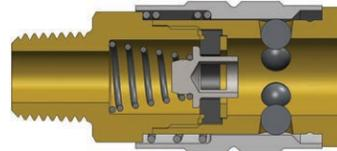
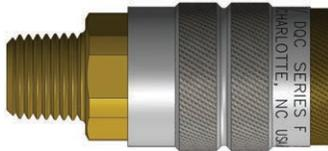

Body Size	F-Series Manual Industrial Interchange Coupler (Male Threads)											
	Part Detail			List Price	Length		Maximum OD		Hex Inch	Weight Lb	Package Qty	
	Part Number	Threads	Material		Inch	mm	Inch	mm			Bag	Box
1/4"	2FM1-B	1/8" - 27 NPTF	brass	<b>\$11.25</b>	1.97	50.0	0.88	22.4	3/4"	0.18	10	100
1/4"	2FM1-S	1/8" - 27 NPTF	303 stainless	<b>54.97</b>	1.97	50.0	0.88	22.4	3/4"	0.18	10	100
1/4"	2FBM1-B	1/8" - 28 BSPT	brass	<b>12.28</b>	1.97	50.0	0.88	22.4	3/4"	0.18	10	100
1/4"	2FM2	1/4" - 18 NPTF	steel	<b>11.91</b>	2.04	51.8	0.88	22.4	3/4"	0.18	10	100
1/4"	2FM2-B	1/4" - 18 NPTF	brass	<b>8.53</b>	2.04	51.8	0.88	22.4	3/4"	0.19	10	100
1/4"	2FM2-S	1/4" - 18 NPTF	303 stainless	<b>45.61</b>	2.04	51.8	0.88	22.4	3/4"	0.18	10	100
1/4"	2FBM2-B	1/4" - 19 BSPT	brass	<b>12.28</b>	2.04	51.8	0.88	22.4	3/4"	0.19	10	100
1/4"	2FM3-B	3/8" - 18 NPTF	brass	<b>11.25</b>	2.08	52.8	0.88	22.4	3/4"	0.19	10	100
1/4"	2FM3-S	3/8" - 18 NPTF	303 stainless	<b>54.97</b>	2.08	52.8	0.88	22.4	3/4"	0.19	10	100
1/4"	2FBM3-B	3/8" - 19 BSPT	brass	<b>12.28</b>	2.08	52.8	0.88	22.4	3/4"	0.19	10	100
3/8"	3FM2	1/4" - 18 NPTF	steel	<b>21.99</b>	2.45	62.2	1.06	26.9	7/8"	0.26	10	50
3/8"	3FM3	3/8" - 18 NPTF	steel	<b>18.94</b>	2.46	62.5	1.06	26.9	7/8"	0.27	10	50
3/8"	3FM3-S	3/8" - 18 NPTF	303 stainless	<b>81.86</b>	2.46	62.5	1.06	26.9	7/8"	0.28	10	50
3/8"	3FBM3	3/8" - 19 BSPT	steel	<b>21.99</b>	2.46	62.5	1.06	26.9	7/8"	0.27	10	50
3/8"	3FM4	1/2" - 14 NPTF	steel	<b>24.33</b>	2.55	64.8	1.06	26.9	7/8"	0.29	10	50
1/2"	4FM3	3/8" - 18 NPTF	steel	<b>29.94</b>	2.97	75.4	1.19	30.2	1"	0.42	5	30
1/2"	4FM4	1/2" - 14 NPTF	steel	<b>21.75</b>	3.07	78.0	1.19	30.2	1"	0.45	5	30
1/2"	4FM4-S	1/2" - 14 NPTF	303 stainless	<b>111.45</b>	3.07	78.0	1.19	30.2	1"	0.47	5	30
1/2"	4FBM4	1/2" - 14 BSPT	steel	<b>29.94</b>	3.07	78.0	1.19	30.2	1"	0.45	5	30
1/2"	4FM6	3/4" - 14 NPTF	steel	<b>31.46</b>	3.12	79.2	1.19	30.2	1-1/16"	0.50	5	30

## DF-Series Pneumatic Couplings

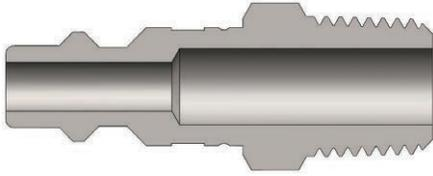

Body Size	DF-Series Industrial Interchange Nipple (Male Threads)											
	Part Detail			List Price	Length		Maximum OD		Hex Inch	Weight Lb	Package Qty	
	Part Number	Threads	Material		Inch	mm	Inch	mm			Bag	Box
1/4"	D2M1	1/8" - 27 NPTF	steel	<b>\$2.75</b>	1.57	39.9	0.58	14.7	1/2"	0.05	10	100
1/4"	D2M1-B	1/8" - 27 NPTF	brass	<b>3.64</b>	1.57	39.9	0.58	14.7	1/2"	0.05	10	100
1/4"	D2M1-S	1/8" - 27 NPTF	303 stainless	<b>12.58</b>	1.57	39.9	0.58	14.7	1/2"	0.05	10	100
1/4"	D2M2	1/4" - 18 NPTF	steel	<b>2.10</b>	1.69	42.9	0.65	16.5	9/16"	0.05	10	100
1/4"	D2M2-B	1/4" - 18 NPTF	brass	<b>2.39</b>	1.69	42.9	0.65	16.5	9/16"	0.05	10	100
1/4"	D2M2-S	1/4" - 18 NPTF	303 stainless	<b>9.13</b>	1.69	42.9	0.65	16.5	9/16"	0.06	10	100
1/4"	D2BM2	1/4" - 19 BSPT	steel	<b>2.83</b>	1.69	42.9	0.65	16.5	9/16"	0.05	10	100
1/4"	D2M3	3/8" - 18 NPTF	steel	<b>3.16</b>	1.75	44.5	0.79	20.1	11/16"	0.05	10	100
1/4"	D2M3-B	3/8" - 18 NPTF	brass	<b>4.54</b>	1.75	44.5	0.79	20.1	11/16"	0.07	10	100
1/4"	D2M3-S	3/8" - 18 NPTF	303 stainless	<b>12.58</b>	1.75	44.5	0.79	20.1	11/16"	0.08	10	100
1/4"	D2BM3	3/8" - 19 BSPT	steel	<b>3.62</b>	1.75	44.5	0.79	20.1	11/16"	0.07	10	100
3/8"	D3M2	1/4" - 18 NPTF	steel	<b>3.56</b>	1.81	46.0	0.79	20.1	11/16"	0.08	10	50
3/8"	D3M3	3/8" - 18 NPTF	steel	<b>3.51</b>	1.87	47.5	0.79	20.1	11/16"	0.09	10	50
3/8"	D3M3-B	3/8" - 18 NPTF	brass	<b>5.85</b>	1.87	47.5	0.79	20.1	11/16"	0.09	10	50
3/8"	D3M3-S	3/8" - 18 NPTF	303 stainless	<b>18.72</b>	1.87	47.5	0.79	20.1	11/16"	0.09	10	50
3/8"	D3BM3	3/8" - 19 BSPT	steel	<b>4.91</b>	1.87	47.5	0.79	20.1	11/16"	0.09	10	50
3/8"	D3M4	1/2" - 14 NPTF	steel	<b>7.01</b>	2.03	51.6	1.01	25.7	7/8"	0.15	10	50
1/2"	D4M2	1/4" - 18 NPTF	steel	<b>6.96</b>	2.13	54.1	0.79	20.1	11/16"	0.14	10	50
1/2"	D4M3	3/8" - 18 NPTF	steel	<b>5.73</b>	2.19	55.6	0.79	20.1	11/16"	0.16	10	50
1/2"	D4M4	1/2" - 14 NPTF	steel	<b>5.85</b>	2.34	59.4	1.01	25.7	7/8"	0.16	10	50
1/2"	D4M4-B	1/2" - 14 NPTF	brass	<b>9.21</b>	2.34	59.4	1.01	25.7	7/8"	0.18	10	50
1/2"	D4M4-S	1/2" - 14 NPTF	303 stainless	<b>28.65</b>	2.34	59.4	1.01	25.7	7/8"	0.16	10	50
1/2"	D4BM4	1/2" - 14 BSPT	steel	<b>7.54</b>	2.34	59.4	1.01	25.7	7/8"	0.16	10	50
1/2"	D4M6	3/4" - 14 NPTF	steel	<b>10.76</b>	2.50	63.5	1.23	31.2	1-1/16"	0.24	10	50
1/2"	D4M6-B	3/4" - 14 NPTF	brass	<b>13.24</b>	2.50	63.5	1.23	31.2	1-1/16"	0.24	10	50
3/4"	D6M4	1/2" - 14 NPTF	steel	<b>13.54</b>	2.38	60.5	1.52	38.6	1-5/16"	0.22	5	20
3/4"	D6M6	3/4" - 14 NPTF	steel	<b>13.54</b>	2.38	60.5	1.52	38.6	1-5/16"	0.25	5	20
3/4"	D6M8	1" - 11 1/2 NPTF	steel	<b>15.05</b>	2.56	65.0	1.80	45.7	1-9/16"	0.26	5	20

## DF-Series Pneumatic Couplings

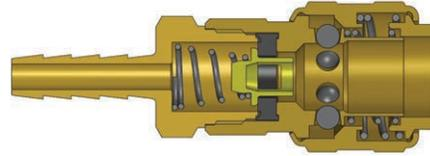

Body Size	D-Series Automatic Industrial Interchange Coupler (Standard Hose Barb)											
	Part Detail			List Price	Length		Maximum OD		Hex Inch	Weight Lb	Package Qty	
	Part Number	Hose ID	Material		Inch	mm	Inch	mm			Bag	Box
1/4"	2DS2-B	1/4"	brass	<b>\$13.45</b>	2.90	73.7	0.98	24.9	11/16"	0.27	10	100
1/4"	2DS2-S	1/4"	303 stainless	<b>75.83</b>	2.90	73.7	0.98	24.9	11/16"	0.27	10	100
1/4"	2DS3-B	3/8"	brass	<b>15.55</b>	2.90	73.7	0.98	24.9	11/16"	0.27	10	100
1/4"	2DS3-S	3/8"	303 stainless	<b>81.84</b>	2.90	73.7	0.98	24.9	11/16"	0.28	10	100
3/8"	3DS2-B	1/4"	brass	<b>28.07</b>	3.00	76.2	1.18	30.0	7/8"	0.37	10	50
3/8"	3DS3-B	3/8"	brass	<b>24.56</b>	3.00	76.2	1.18	30.0	7/8"	0.39	10	50
3/8"	3DS3-S	3/8"	303 stainless	<b>101.10</b>	3.00	76.2	1.18	30.0	7/8"	0.39	10	50
3/8"	3DS4-B	1/2"	brass	<b>29.24</b>	3.00	76.2	1.18	30.0	7/8"	0.41	10	50
1/2"	4DS3-B	3/8"	brass	<b>35.62</b>	3.51	89.2	1.34	34.0	1-1/16"	0.56	5	30
1/2"	4DS4-B	1/2"	brass	<b>36.11</b>	3.51	89.2	1.34	34.0	1-1/16"	0.59	5	30
1/2"	4DS4-S	1/2"	303 stainless	<b>119.13</b>	3.51	89.2	1.34	34.0	1-1/16"	0.59	5	30
1/2"	4DS6-B	3/4"	brass	<b>36.44</b>	3.51	89.2	1.34	34.0	1-1/16"	0.65	5	30
3/4"	6DS4-B	1/2"	brass	<b>59.56</b>	3.00	76.2	1.73	43.9	1-5/16"	0.90	-	20
3/4"	6DS6-B	3/4"	brass	<b>60.20</b>	3.00	76.2	1.73	43.9	1-5/16"	0.93	-	20
3/4"	6DS8-B	1"	brass	<b>60.35</b>	3.24	82.3	1.73	43.9	1-5/16"	1.03	-	20

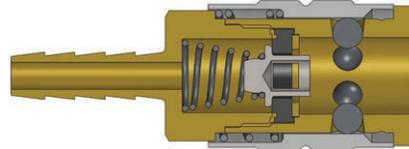
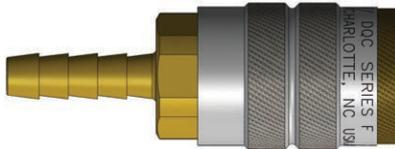

Body Size	F-Series Manual Industrial Interchange Coupler (Standard Hose Barb)											
	Part Detail			List Price	Length		Maximum OD		Hex Inch	Weight Lb	Package Qty	
	Part Number	Hose ID	Material		Inch	mm	Inch	mm			Bag	Box
1/4"	2FS2	1/4"	steel	<b>\$11.91</b>	2.53	64.3	0.88	22.4	3/4"	0.18	10	100
1/4"	2FS2-B	1/4"	brass	<b>11.25</b>	2.53	64.3	0.88	22.4	3/4"	0.18	10	100
1/4"	2FS2-S	1/4"	303 stainless	<b>56.14</b>	2.53	64.3	0.88	22.4	3/4"	0.18	10	100
1/4"	2FS2.5-B	5/16"	brass	<b>11.58</b>	2.53	64.3	0.88	22.4	3/4"	0.18	10	100
1/4"	2FS3-B	3/8"	brass	<b>11.36</b>	2.53	64.3	0.88	22.4	3/4"	0.18	10	100
1/4"	2FS3-S	3/8"	303 stainless	<b>65.50</b>	2.53	64.3	0.88	22.4	3/4"	0.19	10	100
3/8"	3FS2	1/4"	steel	<b>26.24</b>	2.86	72.6	1.06	26.9	7/8"	0.27	10	50
3/8"	3FS3	3/8"	steel	<b>21.34</b>	2.86	72.6	1.06	26.9	7/8"	0.27	10	50
3/8"	3FS3-S	3/8"	303 stainless	<b>86.54</b>	2.86	72.6	1.06	26.9	7/8"	0.28	10	50
3/8"	3FS4	1/2"	steel	<b>25.90</b>	2.86	72.6	1.06	26.9	7/8"	0.28	10	50
1/2"	4FS3	3/8"	steel	<b>29.71</b>	3.49	88.6	1.19	30.2	1"	0.41	5	30
1/2"	4FS4	1/2"	steel	<b>27.48</b>	3.49	88.6	1.19	30.2	1"	0.43	5	30
1/2"	4FS4-S	1/2"	303 stainless	<b>111.45</b>	3.49	88.6	1.19	30.2	1"	0.43	5	30
1/2"	4FS6	3/4"	steel	<b>30.53</b>	3.49	88.6	1.19	30.2	1"	0.48	5	30

## DF-Series Pneumatic Couplings

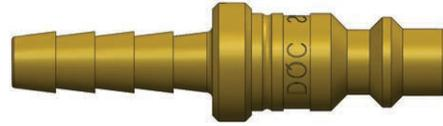
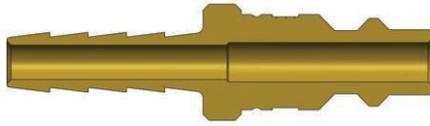

Body Size	DF-Series Industrial Interchange Nipple (Standard Hose Barb)											
	Part Detail			List Price	Length		Maximum OD		Hex Inch	Weight Lb	Package Qty	
	Part Number	Hose ID	Material		Inch	mm	Inch	mm			Bag	Box
1/4"	D2S2	1/4"	steel	\$3.73	2.09	53.1	0.56	14.2	-	0.04	10	100
1/4"	D2S2-B	1/4"	brass	3.92	2.09	53.1	0.56	14.2	-	0.05	10	100
1/4"	D2S2-S	1/4"	303 stainless	11.93	2.09	53.1	0.56	14.2	-	0.05	10	100
1/4"	D2S2.5	5/16"	steel	3.84	2.09	53.1	0.56	14.2	-	0.04	10	100
1/4"	D2S3	3/8"	steel	4.08	2.09	53.1	0.56	14.2	-	0.05	10	100
1/4"	D2S3-B	3/8"	brass	4.62	2.09	53.1	0.56	14.2	-	0.05	10	100
1/4"	D2S3-S	3/8"	303 stainless	13.15	2.09	53.1	0.56	14.2	-	0.05	10	100
3/8"	D3S2	1/4"	steel	7.01	2.21	56.1	0.75	19.1	-	0.06	10	50
3/8"	D3S3	3/8"	steel	5.44	2.21	56.1	0.75	19.1	-	0.07	10	50
3/8"	D3S3-B	3/8"	brass	8.98	2.21	56.1	0.75	19.1	-	0.08	10	50
3/8"	D3S3-S	3/8"	303 stainless	19.30	2.21	56.1	0.75	19.1	-	0.08	10	50
3/8"	D3S4	1/2"	steel	7.60	2.21	56.1	0.75	19.1	-	0.08	10	50
1/2"	D4S3	3/8"	steel	7.60	2.53	64.3	0.75	19.1	-	0.10	10	50
1/2"	D4S3-B	3/8"	brass	9.66	2.53	64.3	0.75	19.1	-	0.11	10	50
1/2"	D4S4	1/2"	steel	7.01	2.53	64.3	0.75	19.1	-	0.12	10	50
1/2"	D4S4-B	1/2"	brass	9.66	2.53	64.3	0.75	19.1	-	0.12	10	50
1/2"	D4S4-S	1/2"	303 stainless	28.65	2.53	64.3	0.75	19.1	-	0.12	10	50
1/2"	D4S6	3/4"	steel	11.40	2.53	64.3	0.94	23.9	-	0.18	10	50
1/2"	D4S6-B	3/4"	brass	14.77	2.53	64.3	0.94	23.9	-	0.18	10	50
3/4"	D6S4	1/2"	steel	19.86	3.49	88.7	1.52	38.6	-	0.19	5	20
3/4"	D6S6	3/4"	steel	19.86	3.49	88.7	1.52	38.6	-	0.23	5	20
3/4"	D6S8	1"	steel	24.07	3.49	88.7	1.52	38.6	-	0.36	5	20

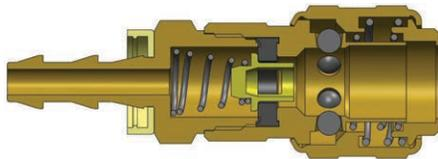

Body Size	D-Series Automatic Industrial Interchange Coupler (Push-Loc Barb)											
	Part Detail			List Price	Length		Maximum OD		Hex Inch	Weight Lb	Package Qty	
	Part Number	Hose ID	Material		Inch	mm	Inch	mm			Bag	Box
1/4"	2DB2-B	1/4"	brass	\$14.27	2.76	70.1	0.98	24.9	11/16"	0.27	10	100
1/4"	2DB3-B	3/8"	brass	16.38	2.77	70.4	0.98	24.9	11/16"	0.29	10	100
3/8"	3DB3-B	3/8"	brass	29.82	2.82	71.7	1.18	30.0	7/8"	0.40	10	50
1/2"	4DB4-B	1/2"	brass	35.08	3.31	84.1	1.34	34.0	1-1/16"	0.56	5	30

## DF-Series Pneumatic Couplings

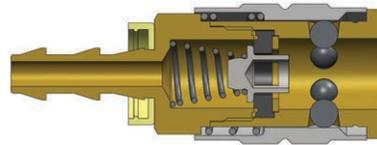

Body Size	F-Series Manual Industrial Interchange Coupler (Push-Loc Barb)											
	Part Detail			List Price	Length		Maximum OD		Hex Inch	Weight Lb	Package Qty	
	Part Number	Hose ID	Material		Inch	mm	Inch	mm			Bag	Box
1/4"	2FB2-B	1/4"	brass	\$11.25	2.49	63.2	0.88	22.4	3/4"	0.18	10	100
1/4"	2FB3-B	3/8"	brass	11.36	2.49	63.2	0.88	22.4	3/4"	0.19	10	100
3/8"	3FB2	1/4"	steel	26.24	2.80	71.1	1.06	26.9	7/8"	0.25	10	50
3/8"	3FB3	3/8"	steel	26.01	2.80	71.1	1.06	26.9	7/8"	0.27	10	50
3/8"	3FB4	1/2"	steel	26.62	2.80	71.1	1.06	26.9	7/8"	0.28	10	50
1/2"	4FB3	3/8"	steel	32.74	3.40	86.4	1.19	30.2	1"	0.40	5	30
1/2"	4FB4	1/2"	steel	31.87	3.40	86.4	1.19	30.2	1"	0.43	5	30

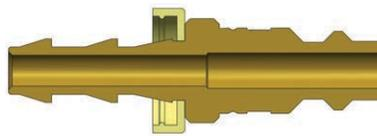

Body Size	DF-Series Industrial Interchange Nipple (Push-Loc Barb)											
	Part Detail			List Price	Length		Maximum OD		Hex Inch	Weight Lb	Package Qty	
	Part Number	Hose ID	Material		Inch	mm	Inch	mm			Bag	Box
1/4"	D2B2	1/4"	steel	\$3.73	2.09	53.1	0.69	17.5	-	0.04	10	100
1/4"	D2B2-B	1/4"	brass	2.21	2.09	53.1	0.69	17.5	-	0.04	10	100
1/4"	D2B3	3/8"	steel	4.08	2.09	53.1	0.86	21.8	-	0.05	10	100
3/8"	D3B2	1/4"	steel	7.60	2.21	56.1	0.75	19.1	-	0.06	10	50
3/8"	D3B3	3/8"	steel	7.41	2.21	56.1	0.75	19.1	-	0.07	10	50
3/8"	D3B4	1/2"	steel	7.95	2.35	59.7	0.75	19.1	-	0.09	10	50
1/2"	D4B4	1/2"	steel	10.99	2.67	67.8	0.75	19.1	-	0.11	10	50
3/4"	D6B6	3/4"	steel	23.39	2.99	75.9	1.00	25.4	-	0.23	5	20

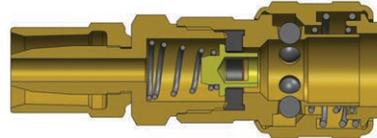

Body Size	DF-Series Industrial Interchange Coupler (Reusable Barb)											
	Part Detail			List Price	Length		Maximum OD		Hex Inch	Weight Lb	Package Qty	
	Part Number	Hose ID x OD	Material		Inch	mm	Inch	mm			Bag	Box
1/4"	2DE2-B	1/4" x 1/2"	brass	\$20.35	2.69	68.3	0.98	24.9	11/16"	0.38	10	100
1/4"	2DH2-B	1/4" x 5/8"	brass	20.35	2.79	70.9	0.98	24.9	11/16"	0.38	10	100
1/4"	2DK3-B	3/8" x 11/16"	brass	22.68	2.79	70.9	0.98	24.9	11/16"	0.39	10	100
1/4"	2DL3-B	3/8" x 3/4"	brass	20.35	2.85	72.4	0.98	24.9	11/16"	0.39	10	100



Body Size	DF-Series Industrial Interchange Nipple (Reusable Barb)											
	Part Detail			List Price	Length		Maximum OD		Hex Inch	Weight Lb	Package Qty	
	Part Number	Hose ID x OD	Material		Inch	mm	Inch	mm			Bag	Box
1/4"	D2E2	1/4" x 1/2"	steel	\$8.43	2.07	52.6	0.69	17.5	9/16"	0.10	10	100
1/4"	D2H2	1/4" x 5/8"	steel	8.43	2.16	54.9	0.81	20.6	9/16"	0.10	10	100
1/4"	D2K3	3/8" x 11/16"	steel	10.51	2.16	54.9	0.81	20.6	9/16"	0.12	10	100
1/4"	D2L3	3/8" x 3/4"	steel	10.93	2.18	55.4	0.95	24.1	9/16"	0.12	10	100

## DF-Series Pneumatic Couplings

### Automatic Safety Exhausting Coupler Operation

The D-Series Automatic coupling has been performing reliably and safely for over 50-years. This amazing coupler is an inexpensive solution for automatically connecting pressurized air lines and is the only one-handed single-stage exhausting safety coupler available in the market today!

Most exhausting safety couplers are a two stage system that are expensive and difficult to operate. Why pay extra for safety? Use the D-Series Automatic Safety Exhausting Couplers, available in sizes 1/4" to 3/4".

1



To disconnect, begin by holding the hose on the nipple side with three of your fingers, leaving your thumb and index finger free.

2



Grab the sleeve with your thumb and index finger and begin to pull the sleeve towards the palm of your hand.

3



After pulling the sleeve, the nipple will move out of the coupler slightly. Continue to hold the hose and coupler sleeve until all air is fully exhausted.

4



After the line is fully exhausted, you are able to safely separate the nipple from the coupler.

# J-Series Pneumatic Couplings

## Interchange Data:

- Truflate Automotive interchange style
- Parker 10-Series
- Rectus 55KM
- Tomco A2100/PT400

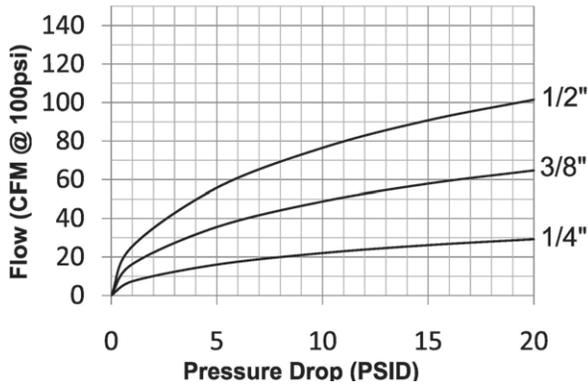

## Materials:

- Machined components are manufactured using solid steel or brass bar stock.
- Stainless steel balls, retaining rings, and springs maximize corrosion resistance and extend service life.
- Steel componentry is plated using ROHS Compliant Trivalent Chrome.
- 1/4" couplers constructed of brass with steel sleeve and steel tubular valve as standard
- 3/8" and 1/2" couplers constructed of steel as standard with steel tubular valves.

## Seal Components:

- Nitrile (Buna-N) seals are standard providing a temperature range of -40°F to +250°F (-40°C to +121°C).

## Rated Pressure Chart:

Body Size	J-Series Truflate Interchange (Connected)															
	Brass Coupler/Steel Plug				Brass Coupler/Plug				Steel Coupler/Plug				303 Stainless Coupler/Plug			
	Max. Working		Burst		Max. Working		Burst		Max. Working		Burst		Max. Working		Burst	
	PSI	Bar	PSI	Bar	PSI	Bar	PSI	Bar	PSI	Bar	PSI	Bar	PSI	Bar	PSI	Bar
1/4"	500	35	11,500	793	300	20	10,500	724	-	-	-	-	-	-	-	-
3/8"	-	-	-	-	-	-	-	-	500	35	18,000	1,241	-	-	-	-
1/2"	-	-	-	-	-	-	-	-	500	35	10,000	690	-	-	-	-

## Technical Specifications:

Body Size	Interchange Standards				Functional Parameters				
	U.S. Military	U.S. Government	International Standards	ANSI/NFPA Standards	Locking Ball Quantity	Air Inclusion	Fluid Loss	Vacuum Rating	Flow $\Delta P = 15$ PSI
1/4"	-	-	-	-	6	N/A	N/A	N/R	26 CFM
3/8"	-	-	-	-	6	N/A	N/A	N/R	58 CFM
1/2"	-	-	-	-	6	N/A	N/A	N/A	91 CFM

## List Price Seal Option Adders:

Body Size	Seal Options				Valve Options						Sleeve Options						Treatments			
	FKM		EPDM		Unvalved		Brass		303 SS		Flanged		Sleeve-Lock		Brass		303 SS		Oxy-Clean	
	Pre	Add \$	Pre	Add \$	Suf	Add \$	Suf	Add \$	Suf	Add \$	Suf	Add \$	Suf	Add \$	Suf	Add \$	Suf	Add \$	Suf	Add \$
1/4"	F-	\$2.00	P-	\$2.50	-E	-\$0.65	-BV	\$0.90	-SV	\$0.90	-FS	\$2.60	-LS	\$5.00	-BS	\$2.60	-XS	\$7.60	-C1	\$12.00
3/8"	F-	3.10	P-	N/A	-E	-2.70	-BV	2.90	-SV	2.90	-FS	N/A	-LS	6.00	-BS	N/A	-XS	15.50	-C1	12.00
1/2"	F-	4.40	P-	N/A	-E	-3.00	-BV	3.50	-SV	3.50	-FS	N/A	-LS	7.50	-BS	N/A	-XS	20.00	-C1	14.00
3/4"	F-	N/A	P-	N/A	-E	-3.80	-BV	N/A	-SV	N/A	-FS	N/A	-LS	8.90	-BS	std.	-XS	N/A	-C1	16.00

**!** Operating pressure for couplings utilizing hose barb end connections may be dramatically reduced to that of the hose rating and/or hose end connection combination. Consult hose manufacturer's catalog for hose end connection ratings. If in doubt, test under controlled conditions for suitability to application. Dixon Quick Coupling cannot assume liability for misapplication of production resulting in equipment down-time, lost production, and/or personal injury including death.



## J-Series Pneumatic Couplings

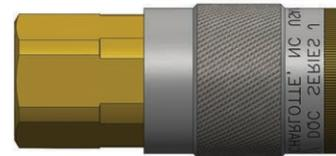
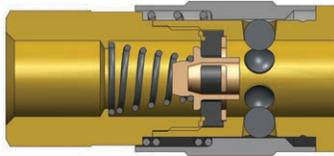

Body Size	J-Series Truflate Interchange Coupler (Female Threads)											
	Part Detail			List Price	Length		Maximum OD		Hex Inch	Weight Lb	Package Qty	
	Part Number	Threads	Material		Inch	mm	Inch	mm			Bag	Box
1/4"	2JF1-B	1/8" - 27 NPTF	brass	\$11.13	1.83	46.5	0.88	22.4	3/4"	0.19	10	100
1/4"	2JF2-B	1/4" - 18 NPTF	brass	8.53	2.04	51.8	0.88	22.4	3/4"	0.19	10	100
1/4"	2JF3-B	3/8" - 18 NPTF	brass	11.13	2.14	54.4	0.88	22.4	13/16"	0.20	10	100
3/8"	3JF2	1/4" - 18 NPTF	steel	23.39	2.25	57.2	1.06	26.9	7/8"	0.30	10	50
3/8"	3JF3	3/8" - 18 NPTF	steel	18.13	2.48	63.0	1.06	26.9	7/8"	0.29	10	50
3/8"	3JF4	1/2" - 14 NPTF	steel	27.48	2.61	66.3	1.06	26.9	1"	0.46	10	50
1/2"	4FF3	3/8" - 18 NPTF	steel	30.99	2.85	72.5	1.24	31.4	1"	0.46	5	30
1/2"	4FF4	1/2" - 14 NPTF	steel	22.93	3.06	77.8	1.24	31.4	1"	0.56	5	30
1/2"	4FF6	3/4" - 14 NPTF	steel	31.58	3.15	79.9	1.24	31.4	1-3/16"	0.63	5	30

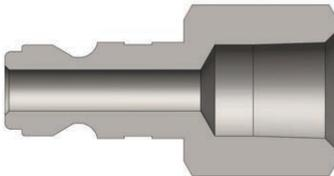

Body Size	J-Series Truflate Interchange Nipple (Female Threads)											
	Part Detail			List Price	Length		Maximum OD		Hex Inch	Weight Lb	Package Qty	
	Part Number	Threads	Material		Inch	mm	Inch	mm			Bag	Box
1/4"	J2F1	1/8" - 27 NPTF	steel	\$3.45	1.34	34.0	0.65	16.5	9/16"	0.05	10	100
1/4"	J2F2	1/4" - 18 NPTF	steel	2.16	1.56	39.6	0.79	20.1	11/16"	0.05	10	100
1/4"	J2F2-B	1/4" - 18 NPTF	brass	3.41	1.56	39.6	0.79	20.1	11/16"	0.05	10	100
1/4"	J2F3	3/8" - 18 NPTF	steel	3.63	1.56	39.6	1.01	25.7	7/8"	0.07	10	100
3/8"	J3F2	1/4" - 18 NPTF	steel	4.97	1.75	44.5	0.79	20.1	11/16"	0.07	10	50
3/8"	J3F3	3/8" - 18 NPTF	steel	4.33	1.75	44.5	1.01	25.7	7/8"	0.10	10	50
3/8"	J3F4	1/2" - 14 NPTF	steel	7.89	1.91	48.5	1.16	29.5	1"	0.12	10	50
1/2"	J4F3	3/8" - 18 NPTF	steel	7.60	2.11	53.6	1.01	25.7	7/8"	0.13	10	50
1/2"	J4F4	1/2" - 14 NPTF	steel	7.31	2.26	57.4	1.16	29.5	1"	0.18	10	50
1/2"	J4F6	3/4" - 14 NPTF	steel	12.86	2.31	58.7	1.37	34.8	1-3/16"	0.26	10	50

## J-Series Pneumatic Couplings

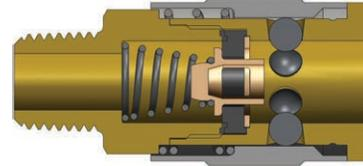

Body Size	J-Series Truflate Interchange Coupler (Male Threads)											
	Part Detail			List Price	Length		Maximum OD		Hex Inch	Weight Lb	Package Qty	
	Part Number	Threads	Material		Inch	mm	Inch	mm			Bag	Box
1/4"	2JM1-B	1/8" - 27 NPTF	brass	<b>\$11.25</b>	1.88	47.8	0.88	22.4	3/4"	0.17	10	100
1/4"	2JM2-B	1/4" - 18 NPTF	brass	<b>8.53</b>	2.047	52.0	0.88	22.4	3/4"	0.18	10	100
1/4"	2JM3-B	3/8" - 18 NPTF	brass	<b>11.25</b>	2.08	52.8	0.88	22.4	3/4"	0.19	10	100
3/8"	3JM2	1/4" - 18 NPTF	steel	<b>21.99</b>	2.45	62.2	1.06	26.9	7/8"	0.26	10	50
3/8"	3JM3	3/8" - 18 NPTF	steel	<b>18.94</b>	2.46	62.5	1.06	26.9	7/8"	0.27	10	50
3/8"	3JM4	1/2" - 14 NPTF	steel	<b>24.33</b>	2.55	64.8	1.06	26.9	7/8"	0.28	10	50
1/2"	4FM3	3/8" - 18 NPTF	steel	<b>29.94</b>	2.97	75.4	1.19	30.2	1"	0.42	5	30
1/2"	4FM4	1/2" - 14 NPTF	steel	<b>21.75</b>	3.07	78.0	1.19	30.2	1"	0.45	5	30
1/2"	4FM6	3/4" - 14 NPTF	steel	<b>31.46</b>	3.12	79.2	1.19	30.2	1-1/16"	0.50	5	30

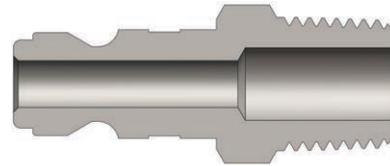

Body Size	J-Series Truflate Interchange Nipple (Male Threads)											
	Part Detail			List Price	Length		Maximum OD		Hex Inch	Weight Lb	Package Qty	
	Part Number	Threads	Material		Inch	mm	Inch	mm			Bag	Box
1/4"	J2M1	1/8" - 27 NPTF	steel	<b>\$2.75</b>	1.47	37.3	0.58	14.7	1/2"	0.04	10	100
1/4"	J2M2	1/4" - 18 NPTF	steel	<b>2.10</b>	1.59	40.4	0.65	16.5	9/16"	0.05	10	100
1/4"	J2M2-B	1/4" - 18 NPTF	brass	<b>2.39</b>	1.59	40.4	0.65	16.5	9/16"	0.06	10	100
1/4"	J2M3	3/8" - 18 NPTF	steel	<b>3.16</b>	1.65	41.9	0.79	20.1	11/16"	0.05	10	100
3/8"	J3M2	1/4" - 18 NPTF	steel	<b>3.56</b>	1.78	45.2	0.79	20.1	11/16"	0.08	10	50
3/8"	J3M3	3/8" - 18 NPTF	steel	<b>3.51</b>	1.84	46.7	0.79	20.1	11/16"	0.09	10	50
3/8"	J3M4	1/2" - 14 NPTF	steel	<b>7.01</b>	2	50.8	1.01	25.7	7/8"	0.12	10	50
1/2"	J4M3	3/8" - 18 NPTF	steel	<b>5.73</b>	2.2	55.9	0.79	20.1	11/16"	0.13	10	50
1/2"	J4M4	1/2" - 14 NPTF	steel	<b>5.85</b>	2.35	59.7	1.01	25.7	7/8"	0.17	10	50
1/2"	J4M6	3/4" - 14 NPTF	steel	<b>10.76</b>	2.51	63.8	1.23	31.2	1-1/16"	0.24	10	50

## J-Series Pneumatic Couplings

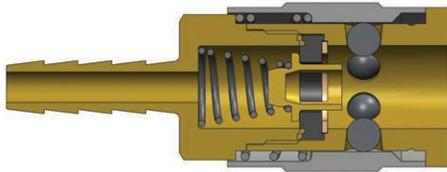

Body Size	J-Series Truflate Interchange Coupler (Standard Hose Barb)											
	Part Detail			List Price	Length		Maximum OD		Hex Inch	Weight Lb	Package Qty	
	Part Number	Hose ID	Material		Inch	mm	Inch	mm			Bag	Box
1/4"	2JS2-B	1/4"	brass	\$11.25	2.53	64.3	0.88	22.4	3/4"	0.18	10	100
1/4"	2JS3-B	3/8"	brass	11.36	2.53	64.3	0.88	22.4	3/4"	0.18	10	100
3/8"	3JS2	1/4"	steel	26.24	2.86	72.6	1.06	26.9	7/8"	0.27	10	50
3/8"	3JS3	3/8"	steel	21.34	2.86	72.6	1.06	26.9	7/8"	0.26	10	50
3/8"	3JS4	1/2"	steel	25.90	2.86	72.6	1.06	26.9	7/8"	0.27	10	50
1/2"	4FS3	3/8"	steel	29.71	3.49	88.6	1.19	30.2	1"	0.41	5	30
1/2"	4FS4	1/2"	steel	27.48	3.49	88.6	1.19	30.2	1"	0.43	5	30
1/2"	4FS6	3/4"	steel	30.53	3.49	88.6	1.19	30.2	1"	0.48	5	30

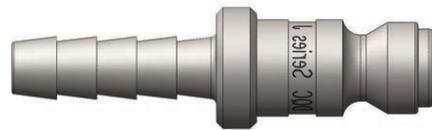
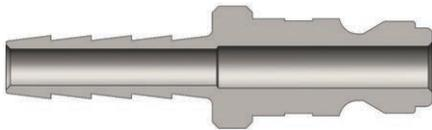

Body Size	J-Series Truflate Interchange Nipple (Standard Hose Barb)											
	Part Detail			List Price	Length		Maximum OD		Hex Inch	Weight Lb	Package Qty	
	Part Number	Hose ID	Material		Inch	mm	Inch	mm			Bag	Box
1/4"	J2S2	1/4"	steel	\$3.73	1.99	50.5	0.56	14.2	-	0.04	10	100
1/4"	J2S3	3/8"	steel	4.08	1.99	50.5	0.56	14.2	-	0.05	10	100
3/8"	J3S2	1/4"	steel	7.01	2.18	55.4	0.75	19.1	-	0.08	10	50
3/8"	J3S3	3/8"	steel	5.44	2.18	55.4	0.75	19.1	-	0.07	10	50
3/8"	J3S4	1/2"	steel	7.60	2.18	55.4	0.75	19.1	-	0.10	10	50
1/2"	J4S3	3/8"	steel	7.60	2.54	64.5	0.75	19.1	-	0.08	10	50
1/2"	J4S4	1/2"	steel	7.01	2.54	64.5	0.75	19.1	-	0.11	10	50
1/2"	J4S6	3/4"	steel	11.40	2.54	64.5	0.94	23.9	-	0.18	10	50

## J-Series Pneumatic Couplings

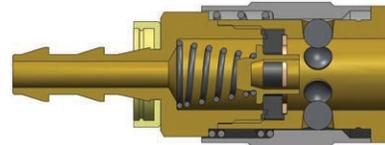
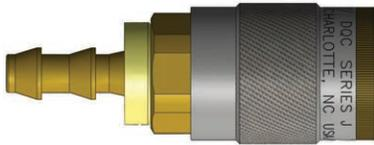

Body Size	J-Series Truflate Interchange Coupler (Push-Loc Barb)											
	Part Detail			List Price	Length		Maximum OD		Hex Inch	Weight Lb	Package Qty	
	Part Number	Hose ID	Material		Inch	mm	Inch	mm			Bag	Box
1/4"	2JB2-B	1/4"	brass	\$11.25	2.37	60.2	0.88	22.4	3/4"	0.19	10	100
1/4"	2JB3-B	3/8"	brass	11.36	2.49	63.2	0.88	22.4	3/4"	0.18	10	100
3/8"	3JB2	1/4"	steel	26.24	2.8	71.1	1.06	26.9	7/8"	0.25	10	50
3/8"	3JB3	3/8"	steel	26.01	2.8	71.1	1.06	26.9	7/8"	0.27	10	50
3/8"	3JB4	1/2"	steel	26.62	2.8	71.1	1.06	26.9	7/8"	0.28	10	50
1/2"	4FB3	3/8"	steel	32.74	3.4	86.4	1.19	30.2	1"	0.40	5	30
1/2"	4FB4	1/2"	steel	31.87	3.4	86.4	1.19	30.2	1"	0.43	5	30

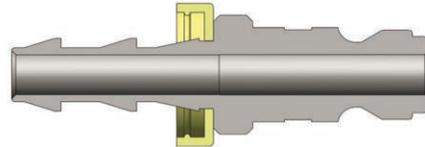

Body Size	J-Series Truflate Interchange Nipple (Push-Loc Barb)											
	Part Detail			List Price	Length		Maximum OD		Hex Inch	Weight Lb	Package Qty	
	Part Number	Hose ID	Material		Inch	mm	Inch	mm			Bag	Box
1/4"	J2B2	1/4"	steel	\$3.73	2.09	53.1	0.69	17.5	-	0.04	10	100
1/4"	J2B3	3/8"	steel	4.08	2.09	53.1	0.86	21.8	-	0.05	10	100
3/8"	J3B3	3/8"	steel	7.41	2.21	56.1	0.75	19.1	-	0.08	10	50
1/2"	J4B4	1/2"	steel	10.99	2.67	67.8	0.75	19.1	-	0.11	10	50

### J Series Profile

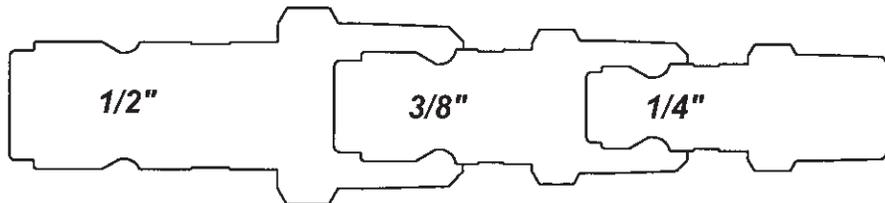

## M-Series Pneumatic Couplings

### Interchange Data:

- ARO 210 (1/4") and ARO 310 (3/8") Interchange
- Automatic Couplings Interchange with ARO 210/310 and Hansen Series 210/310
- Manual Couplings Interchange with Parker 50-Series and Amflow Type 'B'

### Materials:

- Machined components are manufactured using solid steel or brass bar stock.
- Stainless steel balls, retaining rings, pins and springs maximize corrosion resistance and extend service life.
- Steel componentry is plated using ROHS Compliant Trivalent Chrome.
- Automatic couplers constructed of steel.
- Manual couplers constructed of brass.

### Seal Components:

- Nitrile (Buna-N) seals are standard providing a temperature range of -40°F to +250°F (-40°C to +121°C).

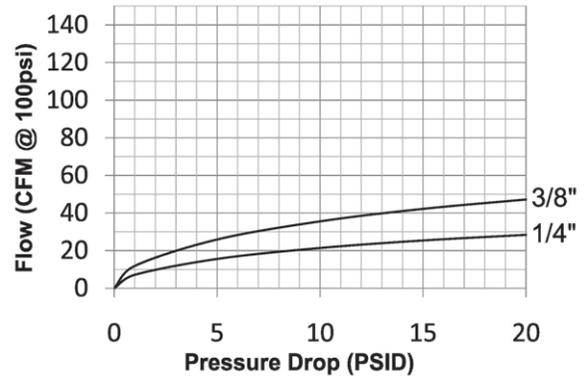

### Rated Pressure Chart:

Body Size	M-Series ARO Interchange (Connected)															
	Auto Coupler/Steel Plug				Auto Coupler/Brass Plug				Manual Coupler/Steel Plug				Manual Coupler/Brass Plug			
	Max. Working		Burst		Max. Working		Burst		Max. Working		Burst		Max. Working		Burst	
	PSI	Bar	PSI	Bar	PSI	Bar	PSI	Bar	PSI	Bar	PSI	Bar	PSI	Bar	PSI	Bar
1/4"	300	20	2,600	179	300	20	5,000	345	300	20	12,400	855	300	20	12,700	876
3/8"	300	20	3,300	228	-	-	-	-	-	-	-	-	-	-	-	-

### Technical Specifications:

Body Size	Interchange Standards				Functional Parameters				
	U.S. Military	U.S. Government	International Standards	ANSI/NFPA Standards	Locking Mechanism	Air Inclusion	Fluid Loss	Vacuum Rating	Flow $\Delta P = 15$ PSI
1/4"	-	-	-	-	Manual - 4 Ball	N/A	N/A	N/R	25 CFM
1/4"	-	-	-	-	Auto - Pins	N/A	N/A	N/R	22 CFM
3/8"	-	-	-	-	Auto - Pins	N/A	N/A	N/R	42 CFM

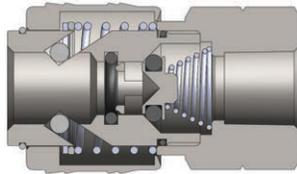

Body Size	M-Series Automatic ARO Interchange Coupler (Female Threads)											
	Part Detail			List Price	Length		Maximum OD		Hex Inch	Weight Lb	Package Qty	
	Part Number	Threads	Material		Inch	mm	Inch	mm			Bag	Box
1/4"	2MF2-PL	1/4" - 18 NPT	steel	\$13.24	1.72	43.6	1.06	27.0	13/16"	0.28	10	100
1/4"	2MF3-PL	3/8" - 18 NPT	steel	15.94	1.72	43.6	1.06	27.0	13/16"	0.28	10	100
3/8"	3MF3-PL	3/8" - 18 NPT	steel	20.16	1.93	49.0	1.26	32.0	1-1/16"	0.43	10	50

## M-Series Pneumatic Couplings

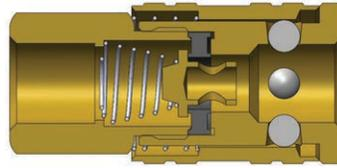
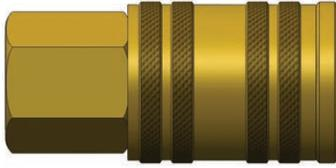

Body Size	M-Series Manual ARO Interchange Coupler (Female Threads)											
	Part Detail			List Price	Length		Maximum OD		Hex Inch	Weight Lb	Package Qty	
	Part Number	Threads	Material		Inch	mm	Inch	mm			Bag	Box
1/4"	2MF2-B	1/4" - 18 NPT	brass	\$11.05	1.97	50.0	0.87	22.0	3/4"	0.20	10	100
1/4"	2MF3-B	3/8" - 18 NPT	brass	13.10	2.05	52.0	0.87	22.0	13/16"	0.20	10	100

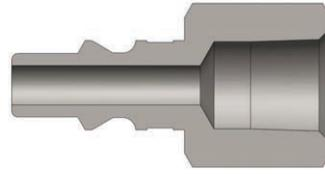

Body Size	M-Series ARO Interchange Nipple (Female Threads)											
	Part Detail			List Price	Length		Maximum OD		Hex Inch	Weight Lb	Package Qty	
	Part Number	Threads	Material		Inch	mm	Inch	mm			Bag	Box
1/4"	M2F2	1/4" - 18 NPTF	steel	\$2.22	1.57	39.9	0.79	20.1	11/16"	0.04	10	100
1/4"	M2F2-B	1/4" - 18 NPTF	brass	2.34	1.57	39.9	0.79	20.1	11/16"	0.04	10	100
1/4"	M2F3	3/8" - 18 NPTF	steel	5.29	1.57	39.9	1.01	25.7	7/8"	0.06	10	100
3/8"	M3F3	3/8" - 18 NPTF	steel	6.38	1.82	46.2	1.01	25.7	7/8"	0.10	10	50

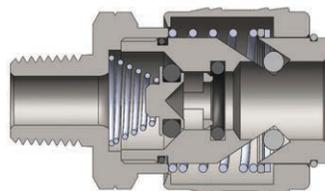
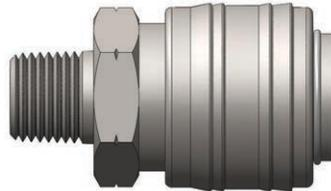

Body Size	M-Series Automatic ARO Interchange Coupler (Male Threads)											
	Part Detail			List Price	Length		Maximum OD		Hex Inch	Weight Lb	Package Qty	
	Part Number	Threads	Material		Inch	mm	Inch	mm			Bag	Box
1/4"	2MM2-PL	1/4" - 18 NPT	steel	\$13.24	1.70	43.2	1.06	27.0	13/16"	0.28	10	100
1/4"	2MM3-PL	3/8" - 18 NPT	steel	15.94	1.80	45.6	1.06	27.0	13/16"	0.28	10	100
3/8"	3MM3-PL	3/8" - 18 NPT	steel	20.16	1.89	48.0	1.26	32.0	1-1/16"	0.43	10	50
3/8"	3MM4-PL	1/2" - 14 NPTF	steel	18.82	1.89	48.0	1.26	32.0	1-1/16"	0.43	10	50

### M Series Profile

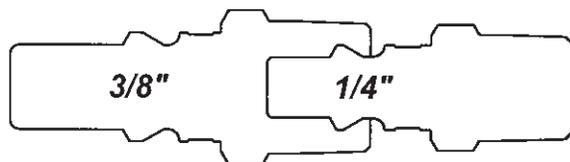

## M-Series Pneumatic Couplings

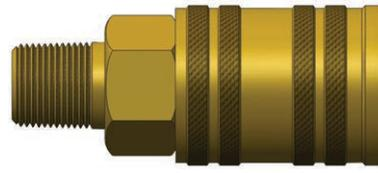
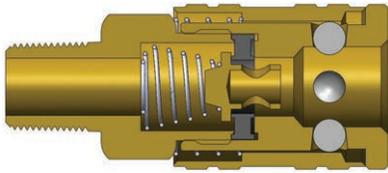

Body Size	M-Series Manual ARO Interchange Coupler (Male Threads)											
	Part Detail			List Price	Length		Maximum OD		Hex Inch	Weight Lb	Package Qty	
	Part Number	Threads	Material		Inch	mm	Inch	mm			Bag	Box
1/4"	2MM2-B	1/4" - 18 NPT	brass	<b>\$11.05</b>	2.13	54.0	0.87	22.0	3/4"	0.19	10	100
1/4"	2MM3-B	3/8" - 18 NPT	brass	<b>13.10</b>	2.13	54.0	0.87	22.0	13/16"	0.20	10	100

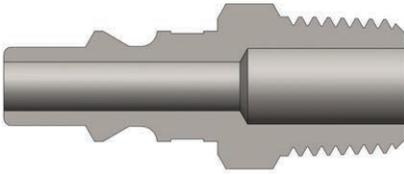

Body Size	M-Series ARO Interchange Nipple (Male Threads)											
	Part Detail			List Price	Length		Maximum OD		Hex Inch	Weight Lb	Package Qty	
	Part Number	Threads	Material		Inch	mm	Inch	mm			Bag	Box
1/4"	M2M1	1/8" - 27 NPTF	steel	<b>\$3.31</b>	1.48	37.6	0.58	14.7	1/2"	0.04	10	100
1/4"	M2M2	1/4" - 18 NPTF	steel	<b>2.16</b>	1.60	40.6	0.65	16.5	9/16"	0.05	10	100
1/4"	M2M2-B	1/4" - 18 NPTF	brass	<b>2.22</b>	1.60	40.6	0.65	16.5	9/16"	0.05	10	100
1/4"	M2M3	3/8" - 18 NPTF	steel	<b>4.51</b>	1.80	45.7	0.79	20.1	11/16"	0.06	10	100
3/8"	M3M3	3/8" - 18 NPTF	steel	<b>6.02</b>	1.91	48.5	0.79	20.1	11/16"	0.10	10	50

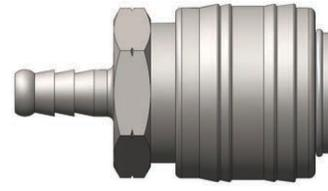
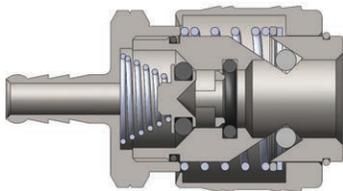

Body Size	M-Series Automatic ARO Interchange Coupler (Standard Hose Barb)											
	Part Detail			List Price	Length		Maximum OD		Hex Inch	Weight Lb	Package Qty	
	Part Number	Hose ID	Material		Inch	mm	Inch	mm			Bag	Box
1/4"	2MS2-PL	1/4"	steel	<b>\$15.33</b>	1.91	48.6	1.06	27.0	13/16"	0.28	10	100
1/4"	2MS2.5-PL	5/16"	steel	<b>15.33</b>	2.33	59.1	1.06	27.0	13/16"	0.28	10	100
1/4"	2MS3-PL	3/8"	steel	<b>16.48</b>	2.50	63.6	1.06	27.0	13/16"	0.30	10	100
3/8"	3MS3-PL	3/8"	steel	<b>18.18</b>	2.60	66.0	1.26	32.0	1-1/16"	0.43	10	50

## M-Series Pneumatic Couplings

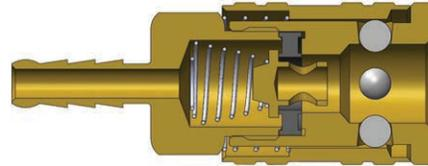

Body Size	M-Series Manual ARO Interchange Coupler (Standard Hose Barb)											
	Part Detail			List Price	Length		Maximum OD		Hex Inch	Weight Lb	Package Qty	
	Part Number	Hose ID	Material		Inch	mm	Inch	mm			Bag	Box
1/4"	2MS2-B	1/4"	brass	<b>\$13.28</b>	2.36	60.0	0.87	22.0	3/4"	0.20	10	100
1/4"	2MS3-B	3/8"	brass	<b>14.04</b>	2.76	70.0	0.87	22.0	13/16"	0.20	10	100

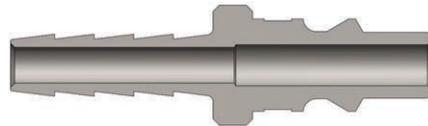

Body Size	M-Series ARO Interchange Nipple (Standard Hose Barb)											
	Part Detail			List Price	Length		Maximum OD		Hex Inch	Weight Lb	Package Qty	
	Part Number	Hose ID	Material		Inch	mm	Inch	mm			Bag	Box
1/4"	M2S2	1/4"	steel	<b>\$4.20</b>	2.00	50.8	0.56	14.2	-	0.03	10	100
1/4"	M2S3	3/8"	steel	<b>5.06</b>	2.00	50.8	0.56	14.2	-	0.05	10	100
3/8"	M3S3	3/8"	steel	<b>7.34</b>	2.25	57.2	0.88	22.4	-	0.09	10	50

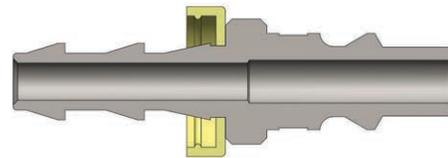

Body Size	M-Series ARO Interchange Nipple (Push-Loc Barb)											
	Part Detail			List Price	Length		Maximum OD		Hex Inch	Weight Lb	Package Qty	
	Part Number	Hose ID	Material		Inch	mm	Inch	mm			Bag	Box
1/4"	M2B2	1/4"	steel	<b>\$3.37</b>	2.09	53.1	0.69	17.5	-	0.03	10	100

**!** It is important to be safe when installing quick disconnect couplings into a pneumatic circuit. Never install a pneumatic coupling directly into an air tool, use a piece of hose that is at least 18" long, between the tool and the coupling, to prevent damage to the coupling. To protect the operator, safety devices, such as a safety check valve and safety cable should be installed in case there is a hose or coupling failure.



# CJ-Series Pneumatic Couplings

### Interchange Data:

- European High-Flow Interchange
- 1/4" interchanges with Coilhose Megaflow, CEJN 320, and Rectus 25KA/26KA
- 3/8" interchanges with Rectus 27KA and Series 410

### Seal Components:

- Nitrile (Buna-N) pneumatically energized seals are standard, providing a temperature range of -40°F to +250°F (-40°C to +121°C).

### Materials:

- Machined components are manufactured using solid steel or brass bar stock.
- Stainless steel balls, retaining rings, and springs maximize corrosion resistance and extend service life.
- Steel componentry is plated using ROHS Compliant Trivalent Chrome.

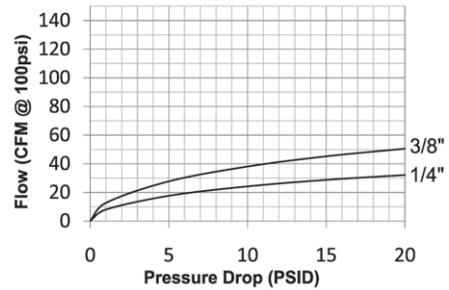

### Rated Pressure Chart:

Body Size	CJ-Series European High-Flow Interchange (Connected)							
	Brass Coupler/Steel Plug				Brass Coupler/Plug			
	Maximum Working		Burst		Maximum Working		Burst	
	PSI	Bar	PSI	Bar	PSI	Bar	PSI	Bar
1/4"	300	20	9,500	655	300	20	7,200	500
3/8"	300	20	8,000	552	300	20	4,400	300

### Technical Specifications:

Body Size	Interchange Standards				Functional Parameters				
	U.S. Military	U.S. Government	International Standards	ANSI/NFPA Standards	Locking Ball Quantity	Air Inclusion	Fluid Loss	Vacuum Rating	Flow $\Delta P = 15 \text{ PSI}$
1/4"	-	-	-	-	6	N/A	N/A	N/R	37 CFM
3/8"	-	-	-	-	6	N/A	N/A	N/R	67 CFM

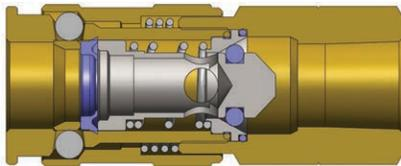

Body Size	CJ-Series European Interchange Coupler (Female Threads)											
	Part Detail			List Price	Length		Maximum OD		Hex Inch	Weight Lb	Package Qty	
	Part Number	Threads	Material		Inch	mm	Inch	mm			Bag	Box
1/4"	2CJF2-B	1/4" - 18 NPT	brass	<b>\$15.38</b>	2.32	59.0	0.92	23.4	3/4"	0.26	10	100
1/4"	2CJBF2-B	1/4" - 19 BSPP	brass	<b>15.38</b>	2.32	59.0	0.92	23.4	3/4"	0.26	10	100
1/4"	2CJF3-B	3/8" - 18 NPT	brass	<b>22.10</b>	2.32	59.0	0.92	23.4	3/4"	0.27	10	100
1/4"	2CJBF3-B	3/8" - 19 BSPP	brass	<b>22.10</b>	2.32	59.0	0.92	23.4	3/4"	0.27	10	100
3/8"	3CJF3-B	3/8" - 18 NPT	brass	<b>31.43</b>	2.54	64.5	1.091	27.7	15/16"	0.46	10	50
3/8"	3CJBF3-B	3/8" - 19 BSPP	brass	<b>31.43</b>	2.54	64.5	1.09	27.7	15/16"	0.46	10	50
3/8"	3CJF4-B	1/2" - 14 NPT	brass	<b>33.66</b>	2.68	68.0	1.09	27.7	15/16"	0.51	10	50
3/8"	3CJBF4-B	1/2" - 14 BSPP	brass	<b>33.66</b>	2.68	68.0	1.09	27.7	15/16"	0.51	10	50

## CJ-Series Pneumatic Couplings

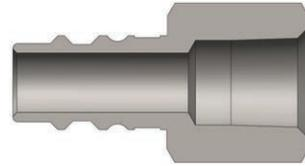

Body Size	CJ-Series European Interchange Nipple (Female Threads)											
	Part Detail			List Price	Length		Maximum OD		Hex Inch	Weight Lb	Package Qty	
	Part Number	Threads	Material		Inch	mm	Inch	mm			Bag	Box
1/4"	CJ2F2-LG	1/4" - 18 NPT	steel	<b>\$4.42</b>	1.42	36.0	0.79	20.1	11/16"	0.07	10	100
1/4"	CJ2F2-B	1/4" - 18 NPT	brass	<b>3.47</b>	1.42	36.0	0.79	20.1	11/16"	0.06	10	100
1/4"	CJ2BF2-LG	1/4" - 19 BSPP	steel	<b>4.42</b>	1.42	36.0	0.79	20.1	11/16"	0.07	10	100
1/4"	CJ2BF2-B	1/4" - 19 BSPP	brass	<b>3.47</b>	1.42	36.0	0.79	20.1	11/16"	0.06	10	100
1/4"	CJ2F3-LG	3/8" - 18 NPT	steel	<b>5.77</b>	1.48	37.5	1.01	25.7	7/8"	0.10	10	100
1/4"	CJ2F3-B	3/8" - 18 NPT	brass	<b>4.38</b>	1.48	37.5	1.01	25.7	7/8"	0.09	10	100
1/4"	CJ2BF3-LG	3/8" - 19 BSPP	steel	<b>5.77</b>	1.48	37.5	1.01	25.7	7/8"	0.10	10	100
1/4"	CJ2BF3-B	3/8" - 19 BSPP	brass	<b>4.38</b>	1.48	37.5	1.01	25.7	7/8"	0.09	10	100
3/8"	CJ3F3	3/8" - 18 NPT	steel	<b>5.80</b>	1.50	38.0	1.01	25.7	7/8"	0.15	10	50
3/8"	CJ3F3-B	3/8" - 18 NPT	brass	<b>4.09</b>	1.50	38.0	1.01	25.7	7/8"	0.15	10	50
3/8"	CJ3BF3	3/8" - 19 BSPP	steel	<b>5.80</b>	1.50	38.0	1.01	25.7	7/8"	0.15	10	50
3/8"	CJ3BF3-B	3/8" - 19 BSPP	brass	<b>4.09</b>	1.50	38.0	1.01	25.7	7/8"	0.15	10	50
3/8"	CJ3F4	1/2" - 14 NPT	steel	<b>7.00</b>	1.71	43.5	1.16	29.5	1"	0.20	10	50
3/8"	CJ3F4-B	1/2" - 14 NPT	brass	<b>4.55</b>	1.71	43.5	1.16	29.5	1"	0.20	10	50
3/8"	CJ3BF4	1/2" - 14 BSPP	steel	<b>7.00</b>	1.71	43.5	1.16	29.5	1"	0.20	10	50
3/8"	CJ3BF4-B	1/2" - 14 BSPP	brass	<b>4.55</b>	1.71	43.5	1.16	29.5	1"	0.20	10	50

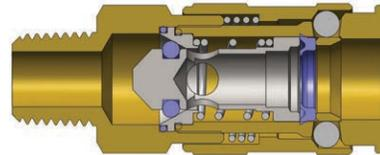

Body Size	CJ-Series European Interchange Coupler (Male Threads)											
	Part Detail			List Price	Length		Maximum OD		Hex Inch	Weight Lb	Package Qty	
	Part Number	Threads	Material		Inch	mm	Inch	mm			Bag	Box
1/4"	2CJM2-B	1/4" - 18 NPT	brass	<b>\$14.97</b>	2.44	62.0	0.92	23.4	3/4"	0.25	10	100
1/4"	2CJBM2-B	1/4" - 19 BSPT	brass	<b>14.97</b>	2.44	62.0	0.92	23.4	3/4"	0.25	10	100
1/4"	2CJM3-B	3/8" - 18 NPT	brass	<b>15.95</b>	2.44	62.0	0.92	23.4	3/4"	0.26	10	100
1/4"	2CJBM3-B	3/8" - 19 BSPT	brass	<b>15.95</b>	2.44	62.0	0.92	23.4	3/4"	0.26	10	100
3/8"	3CJM3-B	3/8" - 18 NPT	brass	<b>31.43</b>	2.64	67.0	1.09	27.7	15/16"	0.42	10	50
3/8"	3CJBM3-B	3/8" - 19 BSPT	brass	<b>31.43</b>	2.64	67.0	1.09	27.7	15/16"	0.42	10	50
3/8"	3CJM4-B	1/2" - 14 NPT	brass	<b>33.66</b>	2.76	70.0	1.09	27.7	15/16"	0.45	10	50
3/8"	3CJBM4-B	1/2" - 14 BSPT	brass	<b>33.66</b>	2.76	70.0	1.09	27.7	15/16"	0.45	10	50

## CJ-Series Pneumatic Couplings

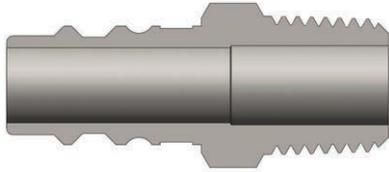

Body Size	CJ-Series European Interchange Nipple (Male Threads)											
	Part Detail			List Price	Length		Maximum OD		Hex Inch	Weight Lb	Package Qty	
	Part Number	Threads	Material		Inch	mm	Inch	mm			Bag	Box
1/4"	CJ2M2-LG	1/4" - 18 NPT	steel	\$4.20	1.48	37.5	0.65	16.5	9/16"	0.07	10	100
1/4"	CJ2M2-B	1/4" - 18 NPT	brass	3.28	1.48	37.5	0.65	16.5	9/16"	0.05	10	100
1/4"	CJ2BM2-LG	1/4" - 19 BSPT	steel	4.20	1.48	37.5	0.65	16.5	9/16"	0.07	10	100
1/4"	CJ2BM2-B	1/4" - 19 BSPT	brass	3.28	1.48	37.5	0.65	16.5	9/16"	0.05	10	100
1/4"	CJ2M3-LG	3/8" - 18 NPT	steel	5.52	1.56	39.5	0.79	20.1	11/16"	0.09	10	100
1/4"	CJ2M3-B	3/8" - 18 NPT	brass	4.31	1.56	39.5	0.79	20.1	11/16"	0.08	10	100
1/4"	CJ2BM3-LG	3/8" - 19 BSPT	steel	5.52	1.56	39.5	0.79	20.1	11/16"	0.09	10	100
1/4"	CJ2BM3-B	3/8" - 19 BSPT	brass	4.31	1.56	39.5	0.79	20.1	11/16"	0.08	10	100
3/8"	CJ3M3	3/8" - 18 NPT	steel	5.44	1.57	40.0	0.79	20.1	11/16"	0.13	10	50
3/8"	CJ3M3-B	3/8" - 18 NPT	brass	3.90	1.57	40.0	0.79	20.1	11/16"	0.13	10	50
3/8"	CJ3BM3	3/8" - 19 BSPT	steel	5.44	1.57	40.0	0.79	20.1	11/16"	0.13	10	50
3/8"	CJ3BM3-B	3/8" - 19 BSPT	brass	5.28	1.57	40.0	0.79	20.1	11/16"	0.13	10	50
3/8"	CJ3M4	1/2" - 14 NPT	steel	7.00	1.81	46.0	1.01	25.7	7/8"	0.18	10	50
3/8"	CJ3M4-B	1/2" - 14 NPT	brass	4.24	1.81	46.0	1.01	25.7	7/8"	0.18	10	50
3/8"	CJ3BM4	1/2" - 14 BSPT	steel	7.00	1.81	46.0	1.01	25.7	7/8"	0.18	10	50
3/8"	CJ3BM4-B	1/2" - 14 BSPT	brass	4.24	1.81	46.0	1.01	25.7	7/8"	0.18	10	50

### CJ Series Profile

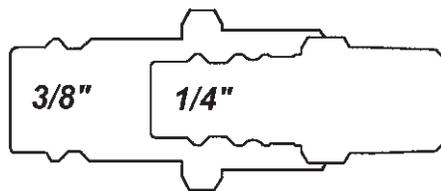

# SHD-Series Pneumatic Couplings

### Interchange Data:

- Schrader Twist-Lock Interchange
- Parker Twist-Lock, Tomco Series-TL, Foster SHD

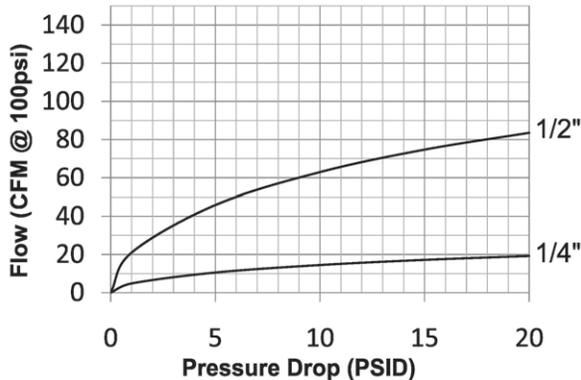

### Materials:

- Machined components are manufactured using solid steel, brass, or aluminum bar stock.
- Stainless steel toggle-pawls, retaining rings, and springs maximize corrosion resistance and extend service life.
- Steel componentry is plated using ROHS Compliant Trivalent Chrome.
- Adapter components are constructed of brass.
- Sleeves are constructed of steel.

### Seal Components:

- Nitrile (Buna-N) seals are standard providing a temperature range of -40°F to +250°F (-40°C to +121°C).

### Rated Pressure Chart:

Body Size	SHD-Series Schrader Interchange (Connected)			
	Coupler/Steel Plug			
	Maximum Working		Burst	
	PSI	Bar	PSI	Bar
1/4"	300	20	6,500	448
1/2"	300	20	13,400	924

### Technical Specifications:

Body Size	Interchange Standards				Functional Parameters				
	U.S. Military	U.S. Government	International Standards	ANSI/NFPA Standards	Locking Mechanism	Air Inclusion	Fluid Loss	Vacuum Rating	Flow $\Delta P = 15$ PSI
1/4"	-	-	-	-	Toggle-Pawls	N/A	N/A	N/R	17 CFM
1/2"	-	-	-	-	Toggle-Pawls	N/A	N/A	N/R	75 CFM

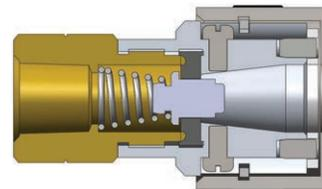

Body Size	SHD-Series Schrader Interchange Coupler (Female Threads)											
	Part Detail			List Price	Length		Maximum OD		Hex Inch	Weight Lb	Package Qty	
	Part Number	Threads	Material		Inch	mm	Inch	mm			Bag	Box
1/4"	2SHDF2	1/4" - 18 NPT	aluminum	<b>\$18.55</b>	2.10	53.3	1.12	28.4	11/16"	0.21	10	100
1/4"	2SHDF3	3/8" - 18 NPT	aluminum	<b>20.35</b>	2.18	55.4	1.12	28.4	11/16"	0.24	10	100
1/2"	4SHDF3	3/8" - 18 NPT	aluminum	<b>33.68</b>	2.59	65.8	1.50	38.1	1-1/8"	0.44	5	30
1/2"	4SHDF4	1/2" - 14 NPT	aluminum	<b>33.68</b>	2.66	67.6	1.50	38.1	1-1/8"	0.44	5	30
1/2"	4SHDF6	3/4" - 14 NPT	aluminum	<b>34.80</b>	2.81	71.4	1.50	38.1	1-1/8"	0.44	5	30

## SHD-Series Pneumatic Couplings

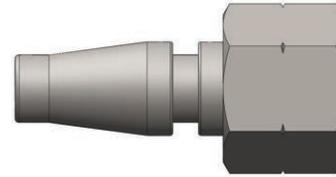
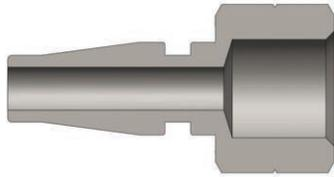

Body Size	SHD-Series Schrader Interchange Nipple (Female Threads)											
	Part Detail			List Price	Length		Maximum OD		Hex Inch	Weight Lb	Package Qty	
	Part Number	Threads	Material		Inch	mm	Inch	mm			Bag	Box
1/4"	SHD2F1	1/8" - 27 NPT	steel	<b>\$3.62</b>	1.49	37.9	0.79	20.1	11/16"	0.04	10	100
1/4"	SHD2F2	1/4" - 18 NPT	steel	<b>3.62</b>	1.62	41.2	0.79	20.1	11/16"	0.07	10	100
1/2"	SHD4F3	3/8" - 18 NPT	steel	<b>7.40</b>	1.79	45.5	1.01	25.7	7/8"	0.14	10	50

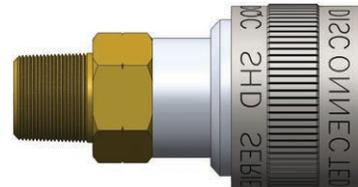
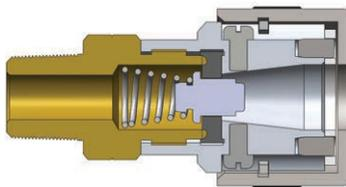

Body Size	SHD-Series Schrader Interchange Coupler (Male Threads)											
	Part Detail			List Price	Length		Maximum OD		Hex Inch	Weight Lb	Package Qty	
	Part Number	Threads	Material		Inch	mm	Inch	mm			Bag	Box
1/4"	2SHDM2	1/4" - 18 NPT	aluminum	<b>\$18.55</b>	2.22	56.4	1.12	28.4	11/16"	0.21	10	100
1/4"	2SHDM3	3/8" - 18 NPT	aluminum	<b>20.35</b>	2.28	57.9	1.12	28.4	11/16"	0.22	10	100
1/2"	4SHDM3	3/8" - 18 NPT	aluminum	<b>33.68</b>	2.55	64.8	1.50	38.1	1-1/8"	0.39	5	30
1/2"	4SHDM4	1/2" - 14 NPT	aluminum	<b>33.68</b>	2.61	66.3	1.50	38.1	1-1/8"	0.40	5	30

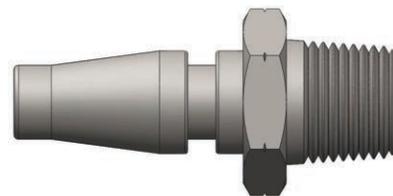
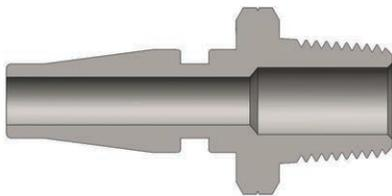

Body Size	SHD-Series Schrader Interchange Nipple (Male Threads)											
	Part Detail			List Price	Length		Maximum OD		Hex Inch	Weight Lb	Package Qty	
	Part Number	Threads	Material		Inch	mm	Inch	mm			Bag	Box
1/4"	SHD2M1	1/8" - 27 NPT	steel	<b>\$3.58</b>	1.54	39.1	0.79	20.1	11/16"	0.05	10	100
1/4"	SHD2M2	1/4" - 18 NPT	steel	<b>3.58</b>	1.72	43.7	0.79	20.1	11/16"	0.05	10	100
1/2"	SHD4M3	3/8" - 18 NPT	steel	<b>7.18</b>	1.81	46.0	1.01	25.7	7/8"	0.12	10	50
1/2"	SHD4M4	1/2" - 14 NPT	steel	<b>7.40</b>	1.87	47.5	1.01	25.7	7/8"	0.12	10	50

## SHD-Series Pneumatic Couplings

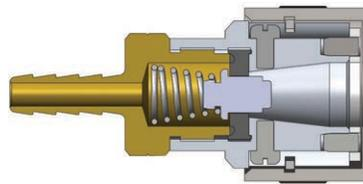
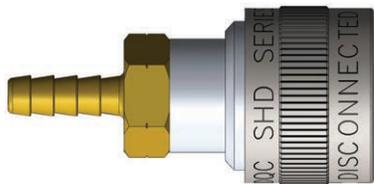

Body Size	SHD-Series Schrader Interchange Coupler (Standard Hose Barb)											
	Part Detail			List Price	Length		Maximum OD		Hex Inch	Weight Lb	Package Qty	
	Part Number	Hose ID	Material		Inch	mm	Inch	mm			Bag	Box
1/4"	2SHDS2	1/4"	aluminum	\$20.18	2.54	64.5	1.12	28.4	11/16"	0.22	10	100
1/4"	2SHDS3	3/8"	aluminum	21.97	2.67	67.8	1.12	28.4	11/16"	0.21	10	100
1/2"	4SHDS3	3/8"	aluminum	35.03	2.99	76.0	1.50	38.1	1-1/8"	0.39	5	30
1/2"	4SHDS4	1/2"	aluminum	35.40	4.23	107.4	1.50	38.1	1-1/8"	0.40	5	30



Body Size	SHD-Series Schrader Interchange Nipple (Standard Hose Barb)											
	Part Detail			List Price	Length		Maximum OD		Hex Inch	Weight Lb	Package Qty	
	Part Number	Hose ID	Material		Inch	mm	Inch	mm			Bag	Box
1/4"	SHD2S2	1/4"	steel	\$3.58	2.03	51.6	0.65	16.5	-	0.04	10	100
1/4"	SHD2S3	3/8"	steel	4.76	2.22	56.4	0.65	16.5	-	0.06	10	100
1/2"	SHD4S3	3/8"	steel	8.18	2.34	59.4	0.8	20.3	-	0.11	10	50
1/2"	SHD4S4	1/2"	steel	8.55	2.53	64.3	0.8	20.3	-	0.12	10	50

### SHD Series Profile

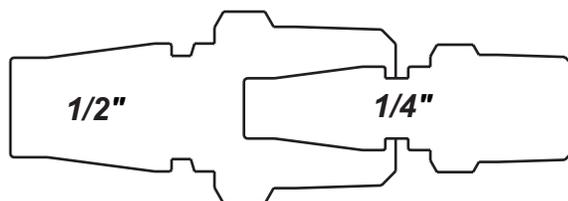

**!** Operating pressure for couplings utilizing hose barb end connections may be dramatically reduced to that of the hose rating and/or hose end connection combination. Consult hose manufacturer's catalog for hose end connection ratings. If in doubt, test under controlled conditions for suitability to application. Dixon Quick Coupling cannot assume liability for misapplication of production resulting in equipment down-time, lost production, and/or personal injury including death.

# L-Series Pneumatic Couplings

### Interchange Data:

- Lincoln Long-Nose Automotive Interchange
- Parker 70-Series, Tomco Series-1110, Coilhose Type-17

### Materials:

- Machined components are manufactured using solid brass or steel bar stock.
- Stainless steel balls, retaining rings, and springs maximize corrosion resistance and extend service life.
- Steel componentry is plated using ROHS Compliant Trivalent Chrome.

### Seal Components:

- Nitrile (Buna-N) seals are standard, providing a temperature range of -40°F to +250°F (-40°C to +121°C).

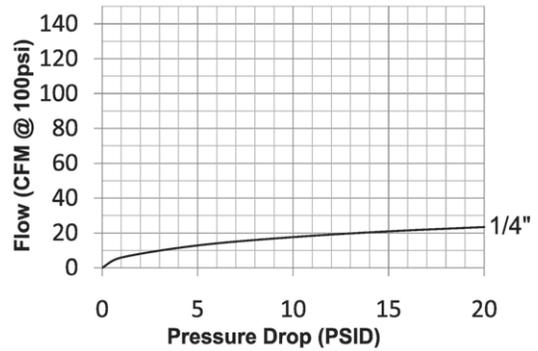

### Rated Pressure Chart:

Body Size	L-Series Lincoln Interchange (Connected)			
	Brass Coupler/Steel Plug			
	Maximum Working		Burst	
	PSI	Bar	PSI	Bar
1/4"	300	21	5,000	345

### Technical Specifications:

Body Size	Interchange Standards				Functional Parameters				
	U.S. Military	U.S. Government	International Standards	ANSI/NFPA Standards	Locking Ball Quantity	Air Inclusion	Fluid Loss	Vacuum Rating	Flow ΔP = 15 PSI
1/4"	-	-	-	-	4	N/A	N/A	N/R	21 CFM

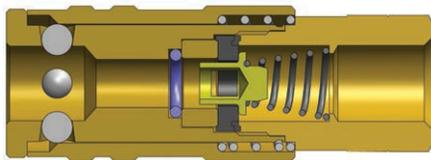

Body Size	L-Series Lincoln Interchange Coupler (Female Threads)											
	Part Detail			List Price	Length		Maximum OD		Hex Inch	Weight Lb	Package Qty	
	Part Number	Threads	Material		Inch	mm	Inch	mm			Bag	Box
1/4"	2LF2-B	1/4" - 18 NPT	brass	\$14.19	2.40	61.0	0.90	22.9	3/4"	0.26	10	100

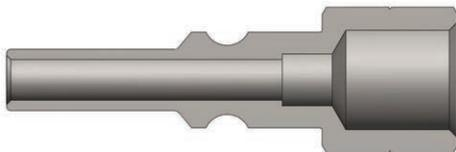

Body Size	L-Series Lincoln Interchange Nipple (Female Threads)											
	Part Detail			List Price	Length		Maximum OD		Hex Inch	Weight Lb	Package Qty	
	Part Number	Threads	Material		Inch	mm	Inch	mm			Bag	Box
1/4"	L2F2	1/4" - 18 NPT	steel	\$4.83	2.10	53.3	0.72	18.3	5/8"	0.05	10	100

## L-Series Pneumatic Couplings

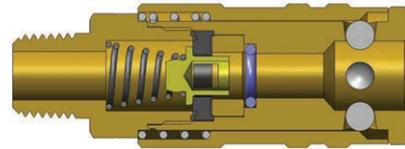

Body Size	L-Series Lincoln Interchange Coupler (Male Threads)											
	Part Detail			List Price	Length		Maximum OD		Hex Inch	Weight Lb	Package Qty	
	Part Number	Threads	Material		Inch	mm	Inch	mm			Bag	Box
1/4"	2LM2-B	1/4"-18 NPT	brass	\$14.19	2.62	66.5	0.90	22.9	3/4"	0.24	10	100

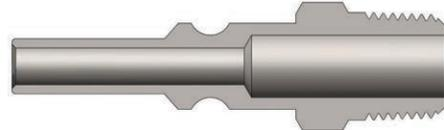

Body Size	L-Series Lincoln Interchange Nipple (Male Threads)											
	Part Detail			List Price	Length		Maximum OD		Hex Inch	Weight Lb	Package Qty	
	Part Number	Threads	Material		Inch	mm	Inch	mm			Bag	Box
1/4"	L2M2	1/4" - 18 NPT	steel	\$4.83	2.25	57.2	0.65	16.5	9/16"	0.06	10	100

### L Series Profile



**!** It is important to be safe when installing quick disconnect couplings into a pneumatic circuit. Never install a pneumatic coupling directly into an air tool, use a piece of hose that is at least 18" long, between the tool and the coupling, to prevent damage to the coupling. To protect the operator, safety devices, such as a safety check valve and safety cable should be installed in case there is a hose or coupling failure.



# U-Series Pneumatic Couplings

### Interchange Data:

- 2U-Series 6-in-1 (Aro 210, Industrial, Truflate, Lincoln, Italian, and CEJN 320)
- 3U-Series 4-in-1 (ARO 310, Industrial, Truflate, and CEJN 410)
- Parker UC-Series, Hansen Auto-Flo 23, and Tomco Series UC

### Materials:

- Machined components are manufactured using solid brass bar stock.
- Stainless steel balls, retaining rings, and springs maximize corrosion resistance and extend service life.
- Valve components are machined from solid brass bar stock.

### Seal Components:

- Nitrile (Buna-N) pneumatically energized seals are standard, temperature range of -40°F to +250°F (-40°C to +121°C).

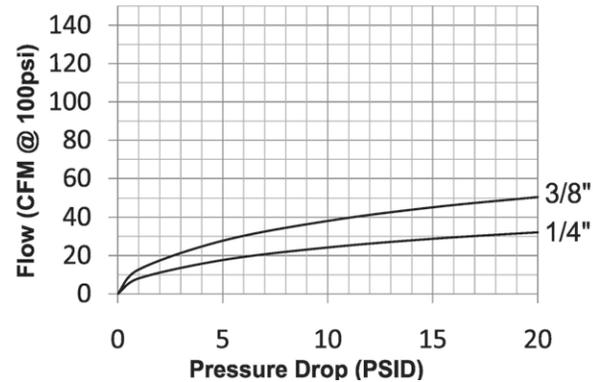

### Rated Pressure Chart:

Body Size	U-Series Automatic Universal Coupler Connected															
	Coupler/Steel DF Plug				Coupler/Steel CJ Plug				Coupler/Steel J Plug				Coupler/Steel M Plug			
	Max. Working		Burst		Max. Working		Burst		Max. Working		Burst		Max. Working		Burst	
	PSI	Bar	PSI	Bar	PSI	Bar	PSI	Bar	PSI	Bar	PSI	Bar	PSI	Bar	PSI	Bar
1/4"	300	20	2,800	193	300	20	9,500	655	300	20	6,400	441	300	20	4,300	297
3/8"	300	20	2,000	138	300	20	8,000	552	300	20	4,000	276	300	20	2,000	138

### Technical Specifications:

Body Size	Interchange Standards				Functional Parameters				
	U.S. Military	U.S. Government	International Standards	ANSI/NFPA Standards	Locking Ball Quantity	Air Inclusion	Fluid Loss	Vacuum Rating	Flow $\Delta P = 15$ PSI
1/4"	-	-	-	-	6	N/A	N/A	N/R	37 SCFM
3/8"	-	-	-	-	6	N/A	N/A	N/R	67 SCFM

• Note: Many competitive Universal couplings are unable to match the performance capabilities of the Dixon U-Series. Each of the competitive Universal couplers only accept three pneumatic nipple styles. Although the universal coupler permits multiple series nipples to mate with one coupler, it is recommended to match like series couplers and nipples. When using a Universal coupler, the lower performance rating between the coupler and nipple must take precedence.

• Dry air: Some pneumatic applications require the pressurized air to be 'dried' to ensure proper operation of equipment and/or application of product (ie. auto body shops). It is best to match like series couplers and nipples in these applications. If it is necessary to use a Universal coupler, lube the seal and valve area regularly to ensure reliable service.

## U-Series Pneumatic Couplings

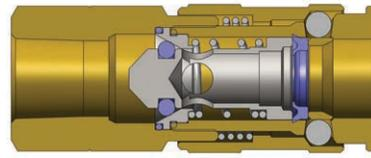

Body Size	U-Series Automatic Universal Coupler (Female Threads)											
	Part Detail			List Price	Length		Maximum OD		Hex Inch	Weight Lb	Package Qty	
	Part Number	Threads	Material		Inch	mm	Inch	mm			Bag	Box
1/4"	2UF2-B	1/4" - 18 NPT	brass	\$17.58	2.32	59.0	0.92	23.4	3/4"	0.26	10	100
1/4"	2UF3-B	3/8" - 18 NPT	brass	18.21	2.32	59.0	0.92	23.4	3/4"	0.27	10	100
3/8"	3UF3-B	3/8" - 18 NPT	brass	34.22	2.54	64.5	1.09	27.7	15/16"	0.31	10	50

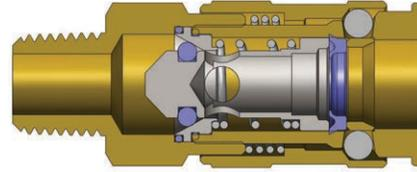

Body Size	U-Series Automatic Universal Coupler (Male Threads)											
	Part Detail			List Price	Length		Maximum OD		Hex Inch	Weight Lb	Package Qty	
	Part Number	Threads	Material		Inch	mm	Inch	mm			Bag	Box
1/4"	2UM2-B	1/4" - 18 NPT	brass	\$17.58	2.44	62.0	0.92	23.4	3/4"	0.24	10	100
1/4"	2UM3-B	3/8" - 18 NPT	brass	19.26	2.44	62.0	0.92	23.4	3/4"	0.25	10	100
3/8"	3UM3-B	3/8" - 18 NPT	brass	34.22	2.64	67.0	1.09	27.7	15/16"	0.30	10	50

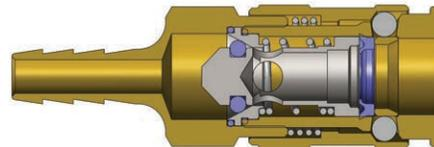

Body Size	U-Series Automatic Universal Coupler (Standard Hose Barb)											
	Part Detail			List Price	Length		Maximum OD		Hex Inch	Weight Lb	Package Qty	
	Part Number	Hose ID	Material		Inch	mm	Inch	mm			Bag	Box
1/4"	2US2-B	1/4"	brass	\$18.67	2.64	67.0	0.92	23.4	3/4"	0.26	10	100
1/4"	2US3-B	3/8"	brass	19.26	2.76	70.0	0.92	23.4	3/4"	0.27	10	100
3/8"	3US3-B	3/8"	brass	35.55	2.99	76.0	1.09	27.7	15/16"	0.31	10	50

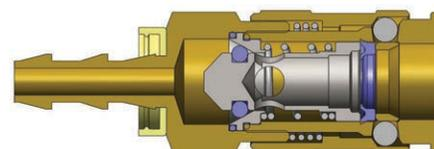

Body Size	U-Series Automatic Universal Coupler (Push-Loc Barb)											
	Part Detail			List Price	Length		Maximum OD		Hex Inch	Weight Lb	Package Qty	
	Part Number	Hose ID	Material		Inch	mm	Inch	mm			Bag	Box
1/4"	2UB2-B	1/4"	brass	\$19.44	2.52	64.0	0.92	23.4	3/4"	0.25	10	100
1/4"	2UB3-B	3/8"	brass	19.44	2.64	67.0	0.92	23.4	3/4"	0.26	10	100

## N-Series Pneumatic Couplings

### Interchange Data:

- Bowes Interchange Bayonet Style
- Interchangeable with Bowes 51000-Series, National Series 'B', Dixon Dixlock, MacDonald Quick-Action

### Materials:

- Machined components are manufactured using solid steel, brass, or 303 stainless steel bar stock.
- Phosphor Bronze retaining ring and spring maximize corrosion resistance and extend service life.
- Steel componentry is plated using ROHS Compliant Trivalent Chrome.
- Dust cap bead chain constructed of stainless steel.

### Seal Components:

- Nitrile (Buna-N) pneumatically energized seals are standard, temperature range -40°F to +250°F (-40°C to +121°C).

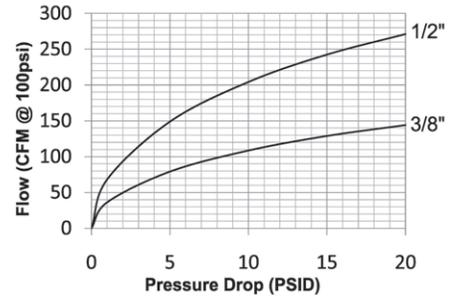

### Rated Pressure Chart:

Body Size	N-Series Bowes Interchange (Connected)											
	Steel Coupler/Plug				Brass Coupler/Plug				303 Stainless Steel Coupler/Plug			
	Max. Working		Burst		Max. Working		Burst		Max. Working		Burst	
	PSI	Bar	PSI	Bar	PSI	Bar	PSI	Bar	PSI	Bar	PSI	Bar
3/8"	500	35	7,000	480	-	-	-	-	-	-	-	-
1/2"	500	35	11,000	755	300	20	8,200		500	35	12,600	

### Technical Specifications:

Body Size	Interchange Standards				Functional Parameters				
	U.S. Military	U.S. Government	International Standards	ANSI/NFPA Standards	Locking Mechanism	Air Inclusion	Fluid Loss	Vacuum Rating	Flow $\Delta P = 10$ PSI
3/8"	-	-	-	-	Latch Tabs	N/A	N/A	N/R	108 CFM
1/2"	MIL-C-3486	A-A-50431A	-	-	Latch Tabs	N/A	N/A	N/R	204 CFM

### List Price Option Adders:

Body Size	Seals		Staked Ferrule Option					
	FKM		1/2" Barb		3/4" Barb		3/4" Stainless Barb	
	Prefix	Add \$	Suffix	Add \$	Suffix	Add \$	Suffix	Add \$
3/8"	F-	N/A	-	N/A	-	N/A	-	N/A
1/2"	F-	\$5.80	-WF43	\$8.15	-WF63	\$8.15	-WFS63	\$10.80

It is important to be safe when installing quick disconnect couplings into a pneumatic circuit. Never install a pneumatic coupling directly into an air tool, use a piece of hose that is at least 18" long, between the tool and the coupling, to prevent damage to the coupling. To protect the operator, safety devices, such as a safety check valve and safety cable should be installed in case there is a hose or coupling failure.



## N-Series Pneumatic Couplings



Body Size	N-Series Bowes Interchange Coupler (Female Threads)											
	Part Detail			List Price	Length		Maximum OD		Hex Inch	Weight Lb	Package Qty	
	Part Number	Threads	Material		Inch	mm	Inch	mm			Bag	Box
1/2"	4NF3	3/8" - 18 NPTF	steel	<b>\$19.35</b>	1.63	41.4	1.54	39.1	1-3/8"	0.51	-	25
1/2"	4NF3-B	3/8" - 18 NPTF	brass	<b>28.94</b>	1.63	41.4	1.54	39.1	1-3/8"	0.55	-	25
1/2"	4NBF3	3/8" - 19 BSPP	steel	<b>19.35</b>	1.63	41.4	1.54	39.1	1-3/8"	0.51	-	25
1/2"	4NF4	1/2" - 14 NPTF	steel	<b>19.35</b>	1.63	41.4	1.54	39.1	1-3/8"	0.46	-	25
1/2"	4NF4-B	1/2" - 14 NPTF	brass	<b>28.94</b>	1.63	41.4	1.54	39.1	1-3/8"	0.50	-	25
1/2"	4NBF4	1/2" - 14 BSPP	steel	<b>19.35</b>	1.63	41.4	1.54	39.1	1-3/8"	0.46	-	25
1/2"	4NBF4-B	1/2" - 14 BSPP	brass	<b>28.94</b>	1.63	41.4	1.54	39.1	1-3/8"	0.50	-	25
1/2"	4NF6	3/4" - 14 NPTF	steel	<b>19.35</b>	1.63	41.4	1.54	39.1	1-3/8"	0.36	-	25
1/2"	4NF6-B	3/4" - 14 NPTF	brass	<b>28.94</b>	1.63	41.4	1.54	39.1	1-3/8"	0.41	-	25
1/2"	4NF6-S	3/4" - 14 NPTF	303 stainless	<b>59.29</b>	1.63	41.4	1.54	39.1	1-3/8"	0.38	-	25
1/2"	4NBF6	3/4" - 14 BSPP	steel	<b>19.35</b>	1.63	41.4	1.54	39.1	1-3/8"	0.36	-	25
1/2"	4NBF6-B	3/4" - 14 BSPP	brass	<b>28.94</b>	1.63	41.4	1.54	39.1	1-3/8"	0.41	-	25
1/2"	4NF8	1" - 11 1/2 NPTF	steel	<b>21.32</b>	1.68	42.6	1.73	43.9	1-1/2"	0.48	-	25
1/2"	4NF8-B	1" - 11 1/2 NPTF	brass	<b>31.77</b>	1.68	42.6	1.73	43.9	1-1/2"	0.53	-	25
1/2"	4NBF8	1" - 11 BSPP	steel	<b>21.32</b>	1.68	42.6	1.73	43.9	1-1/2"	0.48	-	25
1/2"	4NBF8-B	1" - 11 BSPP	brass	<b>31.77</b>	1.68	42.6	1.73	43.9	1-1/2"	0.53	-	25

## N-Series Pneumatic Couplings

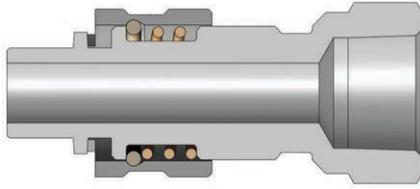

Body Size	N-Series Bowes Interchange Nipple (Female Threads)											
	Part Detail			List Price	Length		Maximum OD		Hex Inch	Weight Lb	Package Qty	
	Part Number	Threads	Material		Inch	mm	Inch	mm			Bag	Box
1/2"	N4F3	3/8" - 18 NPTF	steel	<b>\$23.88</b>	2.73	69.3	1.40	35.6	1-1/8"	0.49	-	25
1/2"	N4F3-B	3/8" - 18 NPTF	brass	<b>37.61</b>	2.73	69.3	1.40	35.6	1-1/8"	0.54	-	25
1/2"	N4BF3	3/8" - 19 BSPP	steel	<b>23.88</b>	2.73	69.3	1.40	35.6	1-1/8"	0.49	-	25
1/2"	N4F4	1/2" - 14 NPTF	steel	<b>23.88</b>	2.73	69.3	1.40	35.6	1-1/8"	0.75	-	25
1/2"	N4F4-B	1/2" - 14 NPTF	brass	<b>37.61</b>	2.73	69.3	1.40	35.6	1-1/8"	0.83	-	25
1/2"	N4BF4	1/2" - 14 BSPP	steel	<b>23.88</b>	2.73	69.3	1.40	35.6	1-1/8"	0.75	-	25
1/2"	N4BF4-B	1/2" - 14 BSPP	brass	<b>37.61</b>	2.73	69.3	1.40	35.6	1-1/8"	0.83	-	25
1/2"	N4F6	3/4" - 14 NPTF	steel	<b>23.88</b>	3.34	84.8	1.58	40.1	1-3/8"	0.66	-	25
1/2"	N4F6-B	3/4" - 14 NPTF	brass	<b>37.61</b>	3.34	84.8	1.58	40.1	1-3/8"	0.74	-	25
1/2"	N4F6-S	3/4" - 14 NPTF	303 stainless	<b>80.96</b>	3.34	84.8	1.58	40.1	1-3/8"	0.69	-	25
1/2"	N4BF6	3/4" - 14 BSPP	steel	<b>23.88</b>	3.34	84.8	1.58	40.1	1-3/8"	0.70	-	25
1/2"	N4BF6-B	3/4" - 14 BSPP	brass	<b>37.61</b>	3.34	84.8	1.58	40.1	1-3/8"	0.74	-	25
1/2"	N4F8	1" - 11 1/2 NPTF	steel	<b>26.43</b>	3.37	85.7	1.73	43.9	1-1/2"	0.72	-	25
1/2"	N4F8-B	1" - 11 1/2 NPTF	brass	<b>39.26</b>	3.37	85.7	1.73	43.9	1-1/2"	0.77	-	25
1/2"	N4BF8	1" - 11 BSPP	steel	<b>26.43</b>	3.37	85.7	1.73	43.9	1-1/2"	0.72	-	25
1/2"	N4BF8-B	1" - 11 BSPP	brass	<b>39.26</b>	3.37	85.7	1.73	43.9	1-1/2"	0.77	-	25

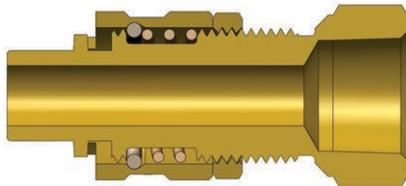

Body Size	N-Series Bowes Interchange Safety-Lock Nipple (Female Threads)											
	Part Detail			List Price	Length		Maximum OD		Hex Inch	Weight Lb	Package Qty	
	Part Number	Threads	Material		Inch	mm	Inch	mm			Bag	Box
1/2"	N4F4-B-LS	1/2" - 14 NPTF	brass	<b>\$41.76</b>	4.28	108.6	1.58	40.1	1-3/8"	0.69	-	25
1/2"	N4F6-B-LS	3/4" - 14 NPTF	brass	<b>41.76</b>	4.38	111.2	1.73	43.9	1-1/2"	0.67	-	25

## N-Series Pneumatic Couplings

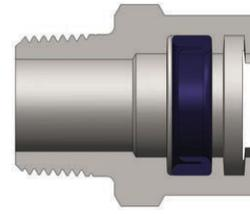

Body Size	N-Series Bowes Interchange Coupler (Male Threads)											
	Part Detail			List Price	Length		Maximum OD		Hex Inch	Weight Lb	Package Qty	
	Part Number	Threads	Material		Inch	mm	Inch	mm			Bag	Box
3/8"	3NM4	1/2" - 14 NPTF	steel	<b>\$42.41</b>	1.72	43.6	1.37	34.8	1-3/16"	0.19	-	40
3/8"	3NBM4	1/2" - 14 BSPT	steel	<b>42.41</b>	1.72	43.6	1.37	34.8	1-3/16"	0.19	-	40
1/2"	4NM3	3/8" - 18 NPTF	steel	<b>19.35</b>	1.77	45.0	1.54	39.1	1-3/8"	0.31	-	25
1/2"	4NM3-B	3/8" - 18 NPTF	brass	<b>28.94</b>	1.77	45.0	1.54	39.1	1-3/8"	0.34	-	25
1/2"	4NBM3	3/8" - 19 BSPT	steel	<b>19.35</b>	1.77	45.0	1.54	39.1	1-3/8"	0.31	-	25
1/2"	4NM4	1/2" - 14 NPTF	steel	<b>19.35</b>	1.77	45.0	1.54	39.1	1-3/8"	0.33	-	25
1/2"	4NM4-B	1/2" - 14 NPTF	brass	<b>28.94</b>	1.77	45.0	1.54	39.1	1-3/8"	0.35	-	25
1/2"	4NBM4	1/2" - 14 BSPT	steel	<b>19.35</b>	1.77	45.0	1.54	39.1	1-3/8"	0.33	-	25
1/2"	4NBM4-B	1/2" - 14 BSPT	brass	<b>28.94</b>	1.77	45.0	1.54	39.1	1-3/8"	0.35	-	25
1/2"	4NM6	3/4" - 14 NPTF	steel	<b>19.35</b>	1.77	45.0	1.54	39.1	1-3/8"	0.34	-	25
1/2"	4NM6-B	3/4" - 14 NPTF	brass	<b>28.94</b>	1.77	45.0	1.54	39.1	1-3/8"	0.38	-	25
1/2"	4NM6-S	3/4" - 14 NPTF	303 stainless	<b>59.43</b>	1.77	45.0	1.54	39.1	1-3/8"	0.35	-	25
1/2"	4NBM6	3/4" - 14 BSPT	steel	<b>19.35</b>	1.77	45.0	1.54	39.1	1-3/8"	0.34	-	25
1/2"	4NBM6-B	3/4" - 14 BSPT	brass	<b>28.94</b>	1.77	45.0	1.54	39.1	1-3/8"	0.38	-	25
1/2"	4NM8	1" - 11 1/2 NPTF	steel	<b>34.61</b>	1.84	46.8	1.73	43.9	1-1/2"	0.45	-	25
1/2"	4NM8-B	1" - 11 1/2 NPTF	brass	<b>31.65</b>	1.84	46.8	1.73	43.9	1-1/2"	0.49	-	25
1/2"	4NBM8	1" - 11 BSPT	steel	<b>34.61</b>	1.84	46.8	1.73	43.9	1-1/2"	0.45	-	25
1/2"	4NBM8-B	1" - 11 BSPT	brass	<b>31.77</b>	1.84	46.8	1.73	43.9	1-1/2"	0.49	-	25

## N-Series Pneumatic Couplings

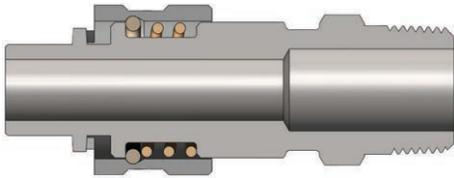

Body Size	N-Series Bowes Interchange Nipple (Male Threads)											
	Part Detail			List Price	Length		Maximum OD		Hex Inch	Weight Lb	Package Qty	
	Part Number	Threads	Material		Inch	mm	Inch	mm			Bag	Box
3/8"	N3M4	1/2" - 14 NPTF	steel	<b>\$51.46</b>	1.72	43.6	1.37	34.8	1-3/16"	0.41	-	40
3/8"	N3BM4	1/2" - 14 BSPT	steel	<b>51.46</b>	1.72	43.6	1.37	34.8	1-3/16"	0.41	-	40
1/2"	N4M3	3/8" - 18 NPTF	steel	<b>24.68</b>	3.65	92.7	1.40	35.6	1-1/8"	0.54	-	25
1/2"	N4M3-B	3/8" - 18 NPTF	brass	<b>36.07</b>	3.65	92.7	1.40	35.6	1-1/8"	0.55	-	25
1/2"	N4BM3	3/8" - 19 BSPT	steel	<b>24.68</b>	3.65	92.7	1.40	35.6	1-1/8"	0.54	-	25
1/2"	N4M4	1/2" - 14 NPTF	steel	<b>24.68</b>	3.65	92.7	1.40	35.6	1-1/8"	0.59	-	25
1/2"	N4M4-B	1/2" - 14 NPTF	brass	<b>36.07</b>	3.65	92.7	1.40	35.6	1-1/8"	0.63	-	25
1/2"	N4BM4	1/2" - 14 BSPT	steel	<b>24.68</b>	3.65	92.7	1.40	35.6	1-1/8"	0.59	-	25
1/2"	N4BM4-B	1/2" - 14 BSPT	brass	<b>36.07</b>	3.65	92.7	1.40	35.6	1-1/8"	0.63	-	25
1/2"	N4M6	3/4" - 14 NPTF	steel	<b>24.68</b>	3.74	95.0	1.40	35.6	1-1/8"	0.59	-	25
1/2"	N4M6-B	3/4" - 14 NPTF	brass	<b>36.07</b>	3.74	95.0	1.40	35.6	1-1/8"	0.64	-	25
1/2"	N4M6-S	3/4" - 14 NPTF	303 stainless	<b>80.96</b>	3.74	95.0	1.40	35.6	1-1/8"	0.62	-	25
1/2"	N4BM6	3/4" - 14 BSPT	steel	<b>24.68</b>	3.74	95.0	1.40	35.6	1-1/8"	0.59	-	25
1/2"	N4BM6-B	3/4" - 14 BSPT	brass	<b>36.07</b>	3.74	95.0	1.40	35.6	1-1/8"	0.64	-	25
1/2"	N4M8	1" - 11 1/2 NPTF	steel	<b>26.43</b>	3.78	95.9	1.54	39.1	1-3/8"	0.71	-	25
1/2"	N4M8-B	1" - 11 1/2 NPTF	brass	<b>37.73</b>	3.78	95.9	1.54	39.1	1-3/8"	0.75	-	25
1/2"	N4BM8	1" - 11 BSPT	steel	<b>26.43</b>	3.78	95.9	1.54	39.1	1-3/8"	0.71	-	25
1/2"	N4BM8-B	1" - 11 BSPT	brass	<b>37.73</b>	3.78	95.9	1.54	39.1	1-3/8"	0.75	-	25

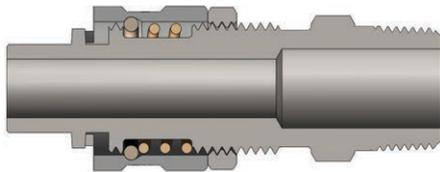

Body Size	N-Series Bowes Interchange Safety-Lock Nipple (Male Threads)											
	Part Detail			List Price	Length		Maximum OD		Hex Inch	Weight Lb	Package Qty	
	Part Number	Threads	Material		Inch	mm	Inch	mm			Bag	Box
1/2"	N4M4-LS	1/2" - 14 NPTF	steel	<b>\$32.72</b>	3.65	92.7	1.40	35.6	1-1/8"	0.63	-	25
1/2"	N4M4-B-LS	1/2" - 14 NPTF	brass	<b>43.86</b>	3.65	92.7	1.40	35.6	1-1/8"	0.69	-	25
1/2"	N4BM4-LS	1/2" - 14 BSPT	steel	<b>32.72</b>	3.65	92.7	1.40	35.6	1-1/8"	0.63	-	25
1/2"	N4M6-LS	3/4" - 14 NPTF	steel	<b>32.72</b>	3.74	95.0	1.40	35.6	1-1/8"	0.65	-	25
1/2"	N4M6-B-LS	3/4" - 14 NPTF	brass	<b>43.86</b>	3.74	95.0	1.40	35.6	1-1/8"	0.69	-	25
1/2"	N4M6-S-LS	3/4" - 14 NPTF	303 stainless	<b>129.45</b>	3.74	95.0	1.40	35.6	1-1/8"	0.67	-	25
1/2"	N4BM6-LS	3/4" - 14 BSPT	steel	<b>32.72</b>	3.74	95.0	1.40	35.6	1-1/8"	0.65	-	25

## N-Series Pneumatic Couplings

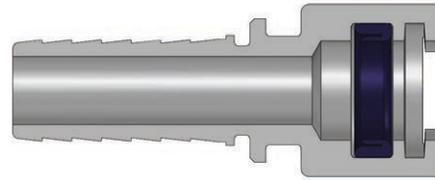
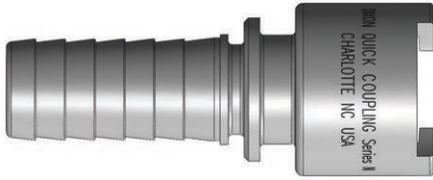

Body Size	N-Series Bowes Interchange Coupler (Hose Barb)											
	Part Detail			List Price	Length		Maximum OD		Hex Inch	Weight Lb	Package Qty	
	Part Number	Hose ID	Material		Inch	mm	Inch	mm			Bag	Box
3/8"	3NCS4	1/2"	steel	<b>\$47.72</b>	2.41	61.2	1.20	30.5	-	0.18	-	40
1/2"	4NS3	3/8"	steel	<b>19.35</b>	2.98	75.7	1.33	33.8	-	0.34	-	25
1/2"	4NS3-B	3/8"	brass	<b>28.94</b>	2.98	75.7	1.33	33.8	-	0.36	-	25
1/2"	4NS4	1/2"	steel	<b>19.35</b>	3.37	85.6	1.33	33.8	-	0.36	-	25
1/2"	4NS4-B	1/2"	brass	<b>28.94</b>	3.37	85.6	1.33	33.8	-	0.40	-	25
1/2"	4NS6	3/4"	steel	<b>19.35</b>	3.37	85.6	1.33	33.8	-	0.40	-	25
1/2"	4NS6-B	3/4"	brass	<b>28.94</b>	3.37	85.6	1.33	33.8	-	0.44	-	25
1/2"	4NS6-S	3/4"	303 stainless	<b>59.43</b>	3.37	85.6	1.33	33.8	-	0.41	-	25
1/2"	4NS8	1"	steel	<b>21.32</b>	3.49	88.7	1.33	33.8	-	0.52	-	25
1/2"	4NS8-B	1"	brass	<b>31.77</b>	3.49	88.7	1.33	33.8	-	0.56	-	25
1/2"	4NS8-S	1"	303 stainless	<b>80.89</b>	3.49	88.7	1.33	33.8	-	0.56	-	25

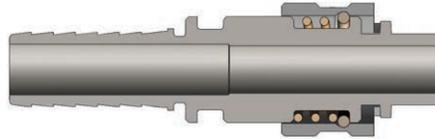

Body Size	N-Series Bowes Interchange Nipple (Hose Barb)											
	Part Detail			List Price	Length		Maximum OD		Hex Inch	Weight Lb	Package Qty	
	Part Number	Hose ID	Material		Inch	mm	Inch	mm			Bag	Box
3/8"	N3CS4	1/2"	steel	<b>\$54.58</b>	3.73	94.8	1.13	28.6	-	0.33	-	25
1/2"	N4S3	3/8"	steel	<b>23.41</b>	4.36	110.7	1.40	35.6	-	0.59	-	25
1/2"	N4S3-B	3/8"	brass	<b>40.21</b>	4.36	110.7	1.40	35.6	-	0.66	-	25
1/2"	N4S4	1/2"	steel	<b>23.88</b>	4.63	117.6	1.40	35.6	-	0.60	-	25
1/2"	N4S4-B	1/2"	brass	<b>40.21</b>	4.63	117.6	1.40	35.6	-	0.66	-	25
1/2"	N4S6	3/4"	steel	<b>23.88</b>	4.77	121.2	1.40	35.6	-	0.59	-	25
1/2"	N4S6-B	3/4"	brass	<b>40.21</b>	4.77	121.2	1.40	35.6	-	0.64	-	25
1/2"	N4S6-S	3/4"	303 stainless	<b>80.96</b>	4.77	121.2	1.40	35.6	-	0.62	-	25
1/2"	N4S8	1"	steel	<b>26.43</b>	4.77	121.2	1.40	35.6	-	0.63	-	25
1/2"	N4S8-B	1"	brass	<b>40.79</b>	4.77	121.2	1.40	35.6	-	0.69	-	25
1/2"	N4S8-S	1"	303 stainless	<b>99.46</b>	4.77	121.2	1.40	35.6	-	0.69	-	25



## N-Series Pneumatic Couplings

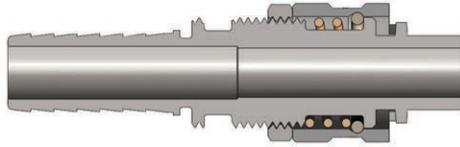

Body Size	N-Series Bows Interchange Safety-Lock Nipple (Hose Barb)											
	Part Detail			List Price	Length		Maximum OD		Hex Inch	Weight Lb	Package Qty	
	Part Number	Hose ID	Material		Inch	mm	Inch	mm			Bag	Box
1/2"	N4S4-LS	1/2"	steel	<b>\$32.72</b>	4.63	117.6	1.40	35.6	-	0.61	-	25
1/2"	N4S4-B-LS	1/2"	brass	<b>43.86</b>	4.63	117.6	1.40	35.6	-	0.69	-	25
1/2"	N4S6-LS	3/4"	steel	<b>31.87</b>	4.77	121.2	1.40	35.6	-	0.61	-	25
1/2"	N4S6-B-LS	3/4"	brass	<b>43.86</b>	4.77	121.2	1.40	35.6	-	0.66	-	25
1/2"	N4S6-S-LS	3/4"	303 stainless	<b>129.45</b>	4.77	121.2	1.40	35.6	-	0.64	-	25

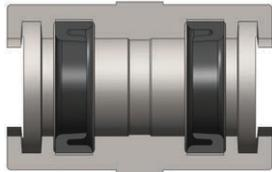

Body Size	N-Series Bows Interchange Gender-Change Union											
	Part Detail			List Price	Length		Maximum OD		Hex Inch	Weight Lb	Package Qty	
	Part Number	Configuration	Material		Inch	mm	Inch	mm			Bag	Box
1/2"	4N4N	coupler to coupler	steel	<b>\$64.03</b>	3.26	82.8	1.33	33.8	-	0.30	-	25



Body Size	N-Series Bows Interchange Protective Nipple Cap											
	Part Detail			List Price	Length		Maximum OD		Hex Inch	Weight Lb	Package Qty	
	Part Number	Cap Lanyard	Material		Inch	mm	Inch	mm			Bag	Box
1/2"	N4DC	SS bead chain	steel	<b>\$22.69</b>	1.50	38.1	1.33	33.8	-	0.32	-	25
1/2"	N4DC-B	SS bead chain	brass	<b>26.06</b>	1.50	38.1	1.33	33.8	-	0.35	-	25

Body Size	N-Series Bows Interchange Replacement Seals											
	Part Detail			List Price	Seal Kit Contents						Package Qty	
	Part Number	Coupler Style	Seal Material								Bag	Box
3/8"	3N-SKIT	all	Nitrile	<b>\$1.39</b>	O-Ring						25	200
1/2"	4N-SKIT	all	Nitrile	<b>1.39</b>	Pneumatically Energized Seal						25	200
1/2"	F-4N-SKIT	all	FKM	<b>2.95</b>	Pneumatically Energized Seal						25	500

# P-Series Pneumatic Couplings

### Interchange Data:

- Thor Finger-Lock Interchange
- Interchanges with Thor PHC-Series, National Series 'A', and Dixon Dual-Lock.

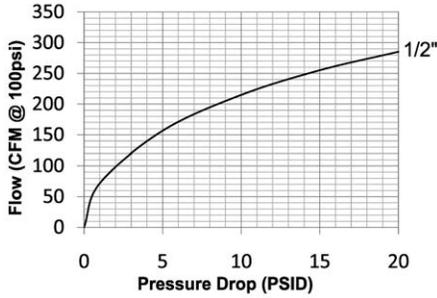

### Materials:

- Machined components are manufactured using solid steel, brass, or 303 stainless steel bar stock.
- Phosphor Bronze retaining ring and spring maximize corrosion resistance and extend service life.
- Steel componentry is plated using ROHS Compliant Trivalent Chrome.
- Steel couplings have a Zinc Cast sleeve

### Seal Components:

- Nitrile (Buna-N) seals are standard, temperature range -40°F to +250°F (-40°C to +121°C).

### Rated Pressure Chart:

Body Size	P-Series Thor Interchange (Connected)											
	Steel Coupler/Plug				Brass Coupler/Plug				303 Stainless Steel Coupler/Plug			
	Max. Working		Burst		Max. Working		Burst		Max. Working		Burst	
	PSI	Bar	PSI	Bar	PSI	Bar	PSI	Bar	PSI	Bar	PSI	Bar
1/2"	300	20	2,600	180	300	20	3,500	240	300	20	4,500	310

### Technical Specifications:

Body Size	Interchange Standards				Functional Parameters				
	U.S. Military	U.S. Government	International Standards	ANSI/NFPA Standards	Locking Mechanism	Air Inclusion	Fluid Loss	Vacuum Rating	Flow $\Delta P = 15 \text{ PSI}$
1/2"	-	-	-	-	Latch Fingers	N/A	N/A	N/R	255 CFM

### List Price Option Adders:

Body Size	Seals		Sleeve Options				Staked Ferrule Option					
	FKM		Flanged		Lock Clip		1/2" Barb		3/4" Barb		3/4" Stainless Barb	
	Prefix	Add \$	Suffix	Add \$	Part Number	List \$	Suffix	Add \$	Suffix	Add \$	Suffix	Add \$
1/2"	F-	\$7.20	-FS	\$3.65	4P-CLIP	\$1.76	-WF43	\$8.15	-WF63	\$8.15	-WFS63	\$10.80

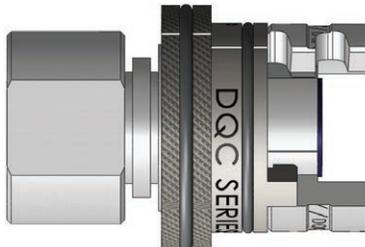

P Series Coupler with -FS  
Flanged Sleeve Option

## P-Series Pneumatic Couplings

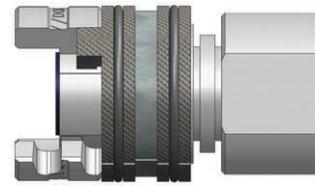
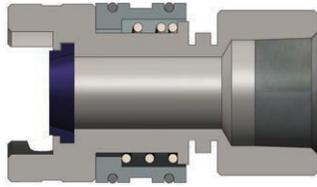

Body Size	P-Series Thor Interchange Coupler (Female Threads)											
	Part Detail			List Price	Length		Maximum OD		Wrench Flats	Weight Lb	Package Qty	
	Part Number	Threads	Material		Inch	mm	Inch	mm			Bag	Box
1/2"	4PF4	1/2" - 14 NPTF	steel	<b>\$37.96</b>	2.75	69.9	1.55	39.4	1-1/4"	0.64	-	25
1/2"	4PF6	3/4" - 14 NPTF	steel	<b>37.96</b>	2.75	69.9	1.55	39.4	1-1/4"	0.55	-	25
1/2"	4PF6-B	3/4" - 14 NPTF	brass	<b>80.19</b>	2.75	69.9	1.55	39.4	1-1/4"	0.58	-	25
1/2"	4PF6-S	3/4" - 14 NPTF	303 stainless	<b>273.53</b>	2.75	69.9	1.55	39.4	1-1/4"	0.57	-	25

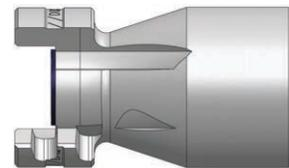
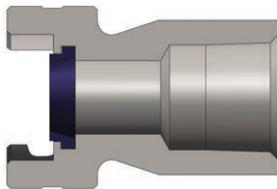

Body Size	P-Series Thor Interchange Nipple (Female Threads)											
	Part Detail			List Price	Length		Maximum OD		Wrench Flats	Weight Lb	Package Qty	
	Part Number	Threads	Material		Inch	mm	Inch	mm			Bag	Box
1/2"	P4F3	3/8"-18 NPTF	steel	<b>\$22.74</b>	1.79	45.5	1.55	39.4	7/8"	0.49	-	25
1/2"	P4F4	1/2"-14 NPTF	steel	<b>24.63</b>	2.25	57.2	1.55	39.4	1-5/16"	0.75	-	25
1/2"	P4F4-B	1/2"-14 NPTF	brass	<b>62.87</b>	2.25	57.2	1.55	39.4	1-5/16"	0.83	-	25
1/2"	P4F6	3/4"-14 NPTF	steel	<b>24.74</b>	2.34	59.4	1.55	39.4	1-5/16"	0.66	-	25
1/2"	P4F6-9	3/4"-14 NPTF	steel/Tefcoat	<b>50.39</b>	2.34	59.4	1.55	39.4	1-5/16"	0.66	-	25
1/2"	P4F6-B	3/4"-14 NPTF	brass	<b>61.29</b>	2.34	59.4	1.55	39.4	1-5/16"	0.74	-	25
1/2"	P4F6-S	3/4"-14 NPTF	303 stainless	<b>141.52</b>	2.34	59.4	1.55	39.4	1-5/16"	0.69	-	25
1/2"	P4F8	1"-11 1/2 NPTF	steel	<b>26.94</b>	2.76	70.1	1.55	39.4	1-7/16"	0.72	-	25
1/2"	P4F8-B	1"-11 1/2 NPTF	brass	<b>63.47</b>	2.76	70.1	1.55	39.4	1-7/16"	0.77	-	25

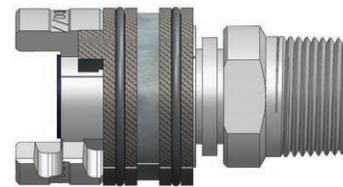
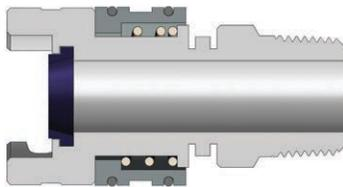

Body Size	P-Series Thor Interchange Coupler (Male Threads)											
	Part Detail			List Price	Length		Maximum OD		Wrench Flats	Weight Lb	Package Qty	
	Part Number	Threads	Material		Inch	mm	Inch	mm			Bag	Box
1/2"	4PM3	3/8" - 18 NPTF	steel	<b>\$33.33</b>	2.93	74.4	1.55	39.4	7/8"	0.48	-	25
1/2"	4PM4	1/2" - 14 NPTF	steel	<b>33.15</b>	2.98	75.7	1.55	39.4	7/8"	0.48	-	25
1/2"	4PM6	3/4" - 14 NPTF	steel	<b>33.15</b>	2.98	75.7	1.55	39.4	1-1/16"	0.51	-	25
1/2"	4PM6-9	3/4" - 14 NPTF	steel/Tefcoat	<b>74.26</b>	2.98	75.7	1.55	39.4	1-1/16"	0.51	-	25
1/2"	4PM6-S	3/4" - 14 NPTF	303 stainless	<b>285.84</b>	2.98	75.7	1.55	39.4	1-1/16"	0.50	-	25
1/2"	4PM8	1" - 11 1/2 NPTF	steel	<b>81.16</b>	3.11	79.0	1.55	39.4	1-3/8"	0.56	-	25

## P-Series Pneumatic Couplings

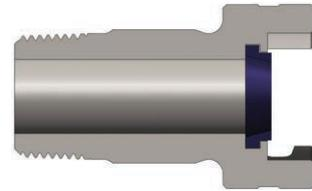
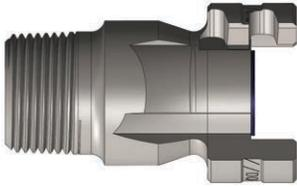

Body Size	P-Series Thor Interchange Nipple (Male Threads)											
	Part Detail			List Price	Length		Maximum OD		Wrench Flats	Weight Lb	Package Qty	
	Part Number	Threads	Material		Inch	mm	Inch	mm			Bag	Box
1/2"	P4M3	3/8" - 18 NPTF	steel	<b>\$19.72</b>	2.00	50.8	1.55	39.4	7/8"	0.29	-	25
1/2"	P4M4	1/2" - 14 NPTF	steel	<b>19.35</b>	2.25	57.2	1.55	39.4	15/16"	0.32	-	25
1/2"	P4M4-B	1/2" - 14 NPTF	brass	<b>58.78</b>	2.25	57.2	1.55	39.4	15/16"	0.35	-	25
1/2"	P4M6	3/4" - 14 NPTF	steel	<b>20.32</b>	2.55	64.8	1.55	39.4	1-1/8"	0.44	-	25
1/2"	P4M6-9	3/4" - 14 NPTF	steel/Tefcoat	<b>50.39</b>	2.55	64.8	1.55	39.4	1-1/8"	0.44	-	25
1/2"	P4M6-B	3/4" - 14 NPTF	brass	<b>63.47</b>	2.55	64.8	1.55	39.4	1-1/8"	0.48	-	25
1/2"	P4M6-S	3/4" - 14 NPTF	303 stainless	<b>141.52</b>	2.55	64.8	1.55	39.4	1-1/8"	0.46	-	25
1/2"	P4M8	1" - 11 1/2 NPTF	steel	<b>22.78</b>	3.25	82.6	1.55	39.4	1-3/8"	0.62	-	25
1/2"	P4M8-B	1" - 11 1/2 NPTF	brass	<b>63.47</b>	3.25	82.6	1.55	39.4	1-3/8"	0.66	-	25

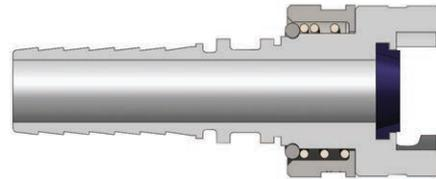

Body Size	P-Series Thor Interchange Coupler (Hose Barb)											
	Part Detail			List Price	Length		Maximum OD		Hex Inch	Weight Lb	Package Qty	
	Part Number	Hose ID	Material		Inch	mm	Inch	mm			Bag	Box
1/2"	4PS3	3/8"	steel	<b>\$35.23</b>	3.53	89.7	1.55	39.4	-	0.48	-	25
1/2"	4PS4	1/2"	steel	<b>35.23</b>	3.95	100.3	1.55	39.4	-	0.52	-	25
1/2"	4PS4-B	1/2"	brass	<b>72.70</b>	3.95	100.3	1.55	39.4	-	0.57	-	25
1/2"	4PS6	3/4"	steel	<b>37.22</b>	3.95	100.3	1.55	39.4	-	0.55	-	25
1/2"	4PS6-9	3/4"	steel/Tefcoat	<b>115.64</b>	3.95	100.3	1.55	39.4	-	0.55	-	25
1/2"	4PS6-B	3/4"	brass	<b>82.73</b>	3.95	100.3	1.55	39.4	-	0.58	-	25
1/2"	4PS6-S	3/4"	303 stainless	<b>327.82</b>	3.95	100.3	1.55	39.4	-	0.59	-	25
1/2"	4PS8	1"	steel	<b>56.71</b>	6.06	153.9	1.55	39.4	-	0.94	-	25
1/2"	4PS8-B	1"	brass	<b>90.21</b>	6.06	153.9	1.55	39.4	-	0.98	-	25

Body Size	P-Series Thor Interchange Replacement Seals							
	Part Detail			List Price	Seal Kit Contents	Package Qty		
	Part Number	Coupler Style	Material			Bag	Box	
1/2"	4P-SKIT	all	Nitrile	<b>\$2.63</b>	Sealing Gasket	25	500	
1/2"	F-4P-SKIT	all	FKM	<b>6.54</b>	Sealing Gasket	25	500	

# NK-Series Pneumatic Couplings

### Interchange Data:

- Japanese Industrial Interchange Pneumatic Coupling
- Nitto Kohki Hi-Cupla 200, Rectus Series 13, and CEJN Series 315

### Materials:

- Machined components are manufactured using solid steel bar stock.
- Stainless steel balls, retaining rings, and springs maximize corrosion resistance and extend service life.
- Steel componentry is plated using chrome-over-nickel plating.

### Seal Components:

- Nitrile (Buna-N) seals are standard, providing a temperature range of -40°F to +250°F (-40°C to +121°C).

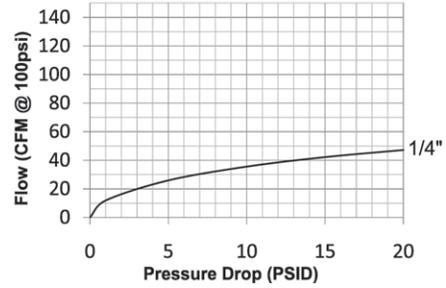

### Rated Pressure Chart:

Body Size	NK-Series Japanese Industrial Interchange (Connected)			
	Coupler/Plug			
	Maximum Working		Burst	
	PSI	Bar	PSI	Bar
1/4"	300	20	13,500	931

### Technical Specifications:

Body Size	Interchange Standards				Functional Parameters				
	U.S. Military	U.S. Government	International Standards	ANSI/NFPA Standards	Locking Ball Quantity	Air Inclusion	Fluid Loss	Vacuum Rating	Flow ΔP = 15 PSI
1/4"	-	-	-	-	4	N/A	N/A	N/R	42 CFM

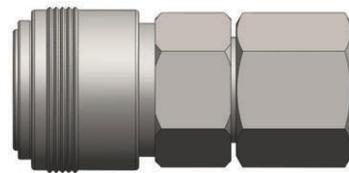
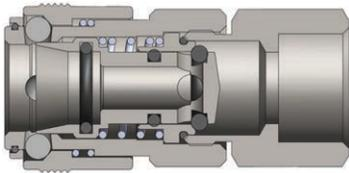

Body Size	NK-Series Japanese Industrial Interchange Coupler (Female Threads)											
	Part Detail			List Price	Length		Maximum OD		Hex Inch	Weight Lb	Package Qty	
	Part Number	Threads	Material		Inch	mm	Inch	mm			Bag	Box
1/4"	2NKF2	1/4" - 18 NPT	steel	\$19.60	1.97	50.0	1.02	26.0	3/4"	0.28	10	100
1/4"	2NKBF2	1/4" -19 BSPP	steel	19.60	1.97	50.0	1.02	26.0	3/4"	0.28	10	100

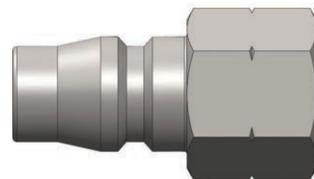
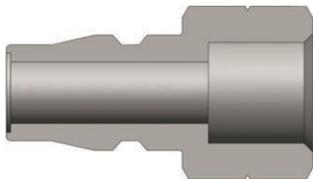

Body Size	NK-Series Japanese Industrial Interchange Nipple (Female Threads)											
	Part Detail			List Price	Length		Maximum OD		Hex Inch	Weight Lb	Package Qty	
	Part Number	Threads	Material		Inch	mm	Inch	mm			Bag	Box
1/4"	NK2F2	1/4" - 18 NPT	steel	\$4.04	1.39	35.2	0.52	13.1	5/8"	0.05	10	100
1/4"	NK2BF2	1/4" - 19 BSPP	steel	4.04	1.39	35.2	0.52	13.1	5/8"	0.05	10	100

## NK-Series Pneumatic Couplings

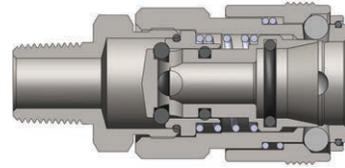
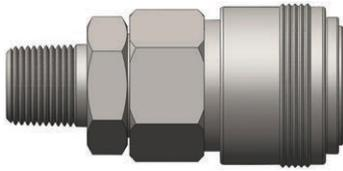

Body Size	NK-Series Japanese Industrial Interchange Coupler (Male Threads)											
	Part Detail			List Price	Length		Maximum OD		Hex Inch	Weight Lb	Package Qty	
	Part Number	Threads	Material		Inch	mm	Inch	mm			Bag	Box
1/4"	2NKM2	1/4" - 18 NPT	steel	<b>\$19.60</b>	2.12	54.0	1.02	26.0	3/4"	0.28	10	100
1/4"	2NKBM2	1/4" - 19 BSPT	steel	<b>19.60</b>	2.12	54.0	1.02	26.0	3/4"	0.29	10	100

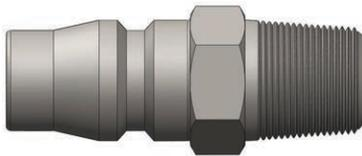

Body Size	NK-Series Japanese Industrial Interchange Nipple (Male Threads)											
	Part Detail			List Price	Length		Maximum OD		Hex Inch	Weight Lb	Package Qty	
	Part Number	Threads	Material		Inch	mm	Inch	mm			Bag	Box
1/4"	NK2M2	1/4" - 18 NPT	steel	<b>\$4.04</b>	1.54	39.2	0.52	13.1	5/8"	0.05	10	100
1/4"	NK2BM2	1/4" - 19 BSPT	steel	<b>4.04</b>	1.54	39.2	0.52	13.1	5/8"	0.05	10	100

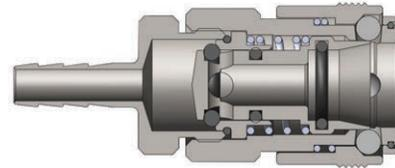
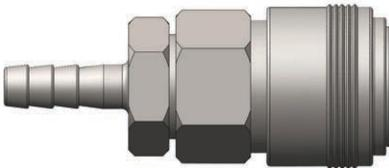

Body Size	NK-Series Japanese Industrial Interchange Coupler (Hose Barb)											
	Part Detail			List Price	Length		Maximum OD		Hex Inch	Weight Lb	Package Qty	
	Part Number	Hose ID	Material		Inch	mm	Inch	mm			Bag	Box
1/4"	2NKS2	1/4"	steel	<b>\$19.57</b>	2.40	61.0	1.02	26.0	3/4"	0.31	10	100



Body Size	NK-Series Japanese Industrial Interchange Nipple (Hose Barb)											
	Part Detail			List Price	Length		Maximum OD		Hex Inch	Weight Lb	Package Qty	
	Part Number	Hose ID	Material		Inch	mm	Inch	mm			Bag	Box
1/4"	NK2S2	1/4"	steel	<b>\$4.04</b>	1.78	45.2	0.44	11.3	-	0.05	10	100

# BR-Series Pneumatic Couplings

### Interchange Data:

- Rectus 21KA, Tomco Series SC, CEJN Series 223

### Materials:

- Machined components are manufactured using solid brass bar stock.
- Stainless steel balls, retaining rings, and springs maximize corrosion resistance and extend service life.
- Machined components are plated with chrome-over-nickel plating.

### Seal Components:

- Nitrile (Buna-N) seals are standard, providing a temperature range of -40°F to +250°F (-40°C to +121°C).

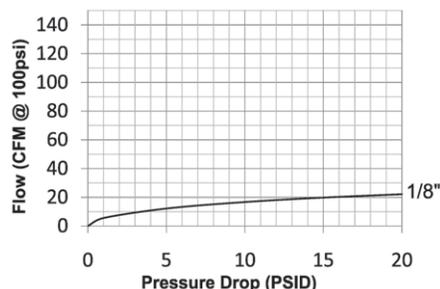

### Rated Pressure Chart:

Body Size	BR-Series Rectus 21-Series Interchange (Connected)			
	Coupler/Plug			
	Maximum Working		Burst	
	PSI	Bar	PSI	Bar
1/8"	300	20	7,000	483

### Technical Specifications:

Body Size	Interchange Standards				Functional Parameters				
	U.S. Military	U.S. Government	International Standards	ANSI/NFPA Standards	Locking Ball Quantity	Air Inclusion	Fluid Loss	Vacuum Rating	Flow ΔP = 15 PSI
1/4"	-	-	-	-	6	N/A	N/A	N/R	20 CFM

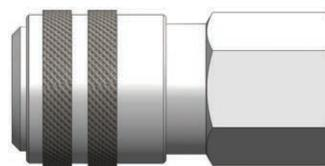
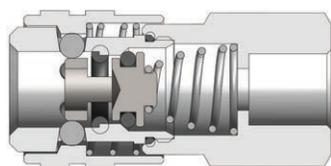

Body Size	BR-Series Rectus 21-Series Interchange Coupler (Female Threads)											
	Part Detail			List Price	Length		Maximum OD		Hex Inch	Weight Lb	Package Qty	
	Part Number	Threads	Material		Inch	mm	Inch	mm			Bag	Box
1/8"	1BRF1-B-7	1/8" - 27 NPT	brass	\$12.71	1.55	39.4	0.65	16.5	9/16"	0.06	10	100
1/8"	1BRBF1-B-7	1/8" - 28 BSPP	brass	12.71	1.55	39.4	0.65	16.5	9/16"	0.06	10	100
1/8"	1BRF2-B-7	1/4" - 18 NPT	brass	12.71	1.77	45.0	0.72	18.3	5/8"	0.10	10	100
1/8"	1BRBF2-B-7	1/4" - 19 BSPP	brass	12.71	1.77	45.0	0.72	18.3	5/8"	0.10	10	100

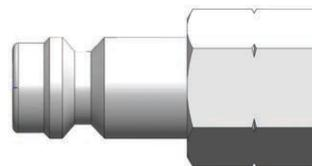
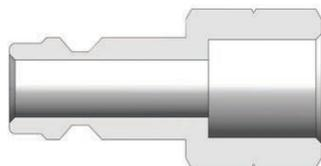

Body Size	BR-Series Rectus 21-Series Interchange Nipple (Female Threads)											
	Part Detail			List Price	Length		Maximum OD		Hex Inch	Weight Lb	Package Qty	
	Part Number	Threads	Material		Inch	mm	Inch	mm			Bag	Box
1/8"	BR1F1-B-E-7	1/8" - 27 NPT	brass	\$3.62	1.14	29.0	0.65	16.5	9/16"	0.04	10	100
1/8"	BR1BF1-B-E-7	1/8" - 28 BSPP	brass	3.62	1.14	29.0	0.65	16.5	9/16"	0.04	10	100
1/8"	BR1F2-B-E-7	1/4" - 18 NPT	brass	3.62	1.33	33.8	0.72	18.3	5/8"	0.07	10	100
1/8"	BR1BF2-B-E-7	1/4" - 19 BSPP	brass	3.62	1.33	33.8	0.72	18.3	5/8"	0.07	10	100

## BR-Series Pneumatic Couplings

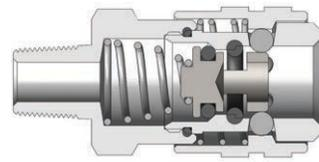

Body Size	BR-Series Rectus 21-Series Interchange Coupler (Male Threads)											
	Part Detail			List Price	Length		Maximum OD		Hex Inch	Weight Lb	Package Qty	
	Part Number	Threads	Material		Inch	mm	Inch	mm			Bag	Box
1/8"	1BRM1-B-7	1/8" - 27 NPT	brass	<b>\$12.71</b>	1.49	37.8	0.65	16.5	9/16"	0.06	10	100
1/8"	1BRGM1-B-7	1/8" - 28 BSPP	brass	<b>12.71</b>	1.49	37.8	0.65	16.5	9/16"	0.06	10	100
1/8"	1BRM2-B-7	1/4" - 18 NPT	brass	<b>12.71</b>	1.61	40.9	0.72	18.3	5/8"	0.07	10	100
1/8"	1BRGM2-B-7	1/4" - 19 BSPP	brass	<b>12.71</b>	1.61	40.9	0.72	18.3	5/8"	0.07	10	100

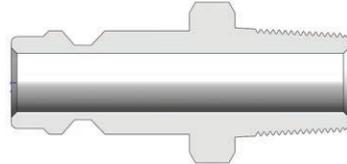
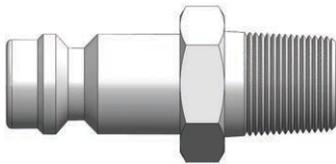

Body Size	BR-Series Rectus 21-Series Interchange Nipple (Male Threads)											
	Part Detail			List Price	Length		Maximum OD		Hex Inch	Weight Lb	Package Qty	
	Part Number	Threads	Material		Inch	mm	Inch	mm			Bag	Box
1/8"	BR1M1-B-E-7	1/8" - 27 NPT	brass	<b>\$3.62</b>	1.06	26.9	0.65	16.5	9/16"	0.03	10	100
1/8"	BR1GM1-B-E-7	1/8" - 28 BSPP	brass	<b>3.62</b>	1.06	26.9	0.65	16.5	9/16"	0.03	10	100
1/8"	BR1M2-B-E-7	1/4" - 18 NPT	brass	<b>3.62</b>	1.20	30.5	0.72	18.3	5/8"	0.04	10	100
1/8"	BR1GM2-B-E-7	1/4" - 19 BSPP	brass	<b>3.62</b>	1.20	30.5	0.72	18.3	5/8"	0.04	10	100

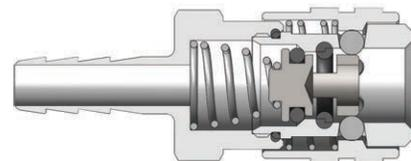
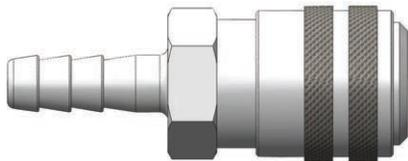

Body Size	BR-Series Rectus 21-Series Interchange Coupler (Hose Barb)											
	Part Detail			List Price	Length		Maximum OD		Hex Inch	Weight Lb	Package Qty	
	Part Number	Hose ID	Material		Inch	mm	Inch	mm			Bag	Box
1/8"	1BRS1.25-B-7	4mm	brass	<b>\$12.71</b>	1.26	32.0	0.35	8.9	9/16"	0.06	10	100
1/8"	1BRS1.86-B-7	6mm	brass	<b>12.71</b>	1.26	32.0	0.35	8.9	9/16"	0.08	10	100
1/8"	1BRS2.83-B-7	9mm	brass	<b>12.71</b>	1.26	32.0	0.35	8.9	9/16"	0.09	10	100

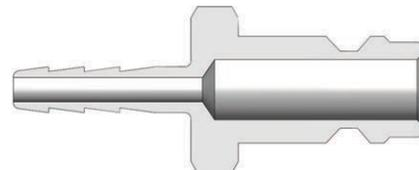
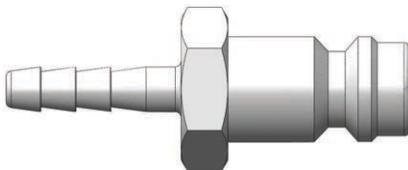

Body Size	BR-Series Rectus 21-Series Interchange Nipple (Hose Barb)											
	Part Detail			List Price	Length		Maximum OD		Hex Inch	Weight Lb	Package Qty	
	Part Number	Hose ID	Material		Inch	mm	Inch	mm			Bag	Box
1/8"	BR1S1.25-B-E-7	4mm	brass	<b>\$3.62</b>	1.26	32.0	0.35	8.9	9/16"	0.03	10	100
1/8"	BR1S1.86-B-E-7	6mm	brass	<b>3.62</b>	1.26	32.0	0.35	8.9	9/16"	0.03	10	100
1/8"	BR1S2.83-B-E-7	9mm	brass	<b>3.62</b>	1.26	32.0	0.35	8.9	9/16"	0.04	10	100



# A-Series Pneumatic Couplings

### Interchange Data:

- Dixon Quick Coupling Proprietary Astronautics

### Materials:

- Machined components are manufactured using solid steel or brass bar stock.
- Stainless steel balls, retaining rings, and springs maximize corrosion resistance and extend service life.
- Steel componentry is plated using ROHS Compliant Trivalent Chrome.
- Couplers are constructed of brass with steel valve as standard.

### Seal Components:

- Nitrile (Buna-N) seals are standard, providing a temperature range of -40°F to +250°F (-40°C to +121°C).

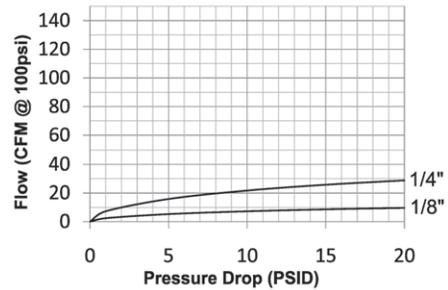

### Rated Pressure Chart:

Body Size	A-Series Astronautics High Pressure Pneumatic (Connected)							
	Brass Coupler/Steel Plug				Brass Coupler/Plug			
	Maximum Working		Burst		Maximum Working		Burst	
	PSI	Bar	PSI	Bar	PSI	Bar	PSI	Bar
1/8"	1,000	70	18,500	1,275	500	35	15,500	1,070
1/4"	1,000	70	8,000	550	500	35	6,500	450

### Technical Specifications:

Body Size	Interchange Standards				Functional Parameters				
	U.S. Military	U.S. Government	International Standards	ANSI/NFPA Standards	Locking Ball Quantity	Air Inclusion	Fluid Loss	Vacuum Rating	Flow ΔP = 15 PSI
1/8"	-	-	-	-	3	N/A	N/A	N/R	8.6 CFM
1/4"	-	-	-	-	3	N/A	N/A	N/R	26 CFM

### List Price Seal Option Adders:

Body Size	Seal Options				Valve Options						Sleeve Options				Treatments	
	FKM		EPDM		Unvalved		Brass		303SS		Flanged		Sleeve-Lock		Oxy-Clean	
	Pre	Add \$	Pre	Add \$	Suf	Add \$	Suf	Add \$	Suf	Add \$	Suf	Add \$	Suf	Add \$	Suf	Add \$
1/8"	F-	\$2.00	P-	\$2.50	-E	-\$0.65	-BV	\$0.90	-SV	\$0.90	-FS	N/A	-LS	\$5.00	-C1	\$12.00
1/4"	F-	N/A	P-	N/A	-E	-3.80	-BV	N/A	-SV	N/A	-FS	N/A	-LS	8.90	-C1	16.00

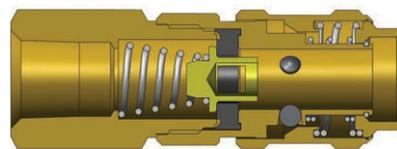
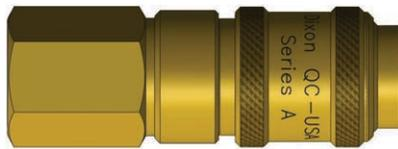

Body Size	A-Series Astronautics High Pressure Pneumatic Coupler (Female Threads)												
	Part Detail				List Price	Length		Maximum OD		Hex Inch	Weight Lb	Package Qty	
	Part Number	Threads	Material	Inch		mm	Inch	mm	Bag			Box	
1/8"	1AF1-B	1/8" - 27 NPTF	brass	\$25.48	1.68	42.7	0.64	16.3	1/2"	0.08	10	100	
1/4"	2AF1-B	1/8" - 27 NPTF	brass	26.64	2.41	61.2	0.77	19.6	1/2"	0.17	10	100	
1/4"	2AF2-B	1/4" - 18 NPTF	brass	26.64	2.70	68.6	0.77	19.6	11/16"	0.16	10	100	

## A-Series Pneumatic Couplings

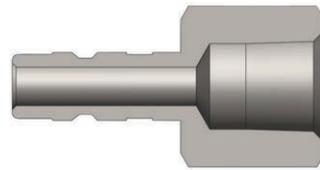

Body Size	A-Series Astronautics High Pressure Pneumatic Nipple (Female Threads)											
	Part Detail			List Price	Length		Maximum OD		Hex Inch	Weight Lb	Package Qty	
	Part Number	Threads	Material		Inch	mm	Inch	mm			Bag	Box
1/8"	A1F1-B	1/8" - 27 NPTF	brass	<b>\$7.82</b>	1.26	32.0	0.58	14.7	1/2"	0.03	10	100
1/4"	A2F1-B	1/8" - 27 NPTF	brass	<b>7.82</b>	1.34	34.0	0.65	16.5	9/16"	0.08	10	100
1/4"	A2F2	1/4" - 18 NPTF	steel	<b>5.96</b>	1.56	39.6	0.79	20.1	11/16"	0.07	10	100
1/4"	A2F2-B	1/4" - 18 NPTF	brass	<b>7.82</b>	1.56	39.6	0.79	20.1	11/16"	0.07	10	100

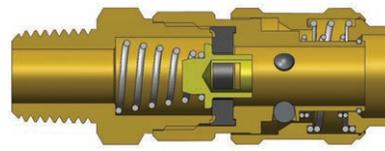

Body Size	A-Series Astronautics High Pressure Pneumatic Coupler (Male Threads)											
	Part Detail			List Price	Length		Maximum OD		Hex Inch	Weight Lb	Package Qty	
	Part Number	Threads	Material		Inch	mm	Inch	mm			Bag	Box
1/8"	1AM1-B	1/8" - 27 NPTF	brass	<b>\$25.48</b>	1.75	44.5	0.64	16.3	1/2"	0.08	10	100
1/4"	2AM1-B	1/8" - 27 NPTF	brass	<b>26.64</b>	2.12	53.8	0.77	19.6	11/16"	0.17	10	100
1/4"	2AM2-B	1/4" - 18 NPTF	brass	<b>26.64</b>	2.23	56.6	0.77	19.6	11/16"	0.16	10	100

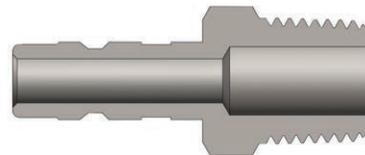

Body Size	A-Series Astronautics High Pressure Pneumatic Nipple (Male Threads)											
	Part Detail			List Price	Length		Maximum OD		Hex Inch	Weight Lb	Package Qty	
	Part Number	Threads	Material		Inch	mm	Inch	mm			Bag	Box
1/8"	A1M1-B	1/8" - 27 NPTF	brass	<b>\$7.82</b>	1.30	33.0	0.51	13.0	7/16"	0.02	10	100
1/4"	A2M2	1/4" - 18 NPTF	steel	<b>5.62</b>	1.59	40.4	0.65	16.5	9/16"	0.03	10	100
1/4"	A2M2-B	1/4" - 18 NPTF	brass	<b>7.82</b>	1.59	40.4	0.65	16.5	9/16"	0.03	10	100

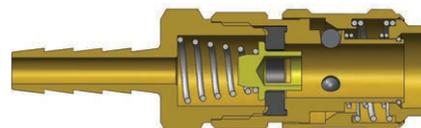

Body Size	A-Series Astronautics High Pressure Pneumatic Coupler (Hose Barb)											
	Part Detail			List Price	Length		Maximum OD		Hex Inch	Weight Lb	Package Qty	
	Part Number	Hose ID	Material		Inch	mm	Inch	mm			Bag	Box
1/8"	1AS1-B	1/8"	brass	<b>\$27.80</b>	1.98	50.3	0.64	16.3	1/2"	0.07	10	100
1/4"	2AS2-B	1/4"	brass	<b>28.95</b>	2.70	68.6	0.77	19.6	11/16"	0.15	10	100

## A-Series Pneumatic Couplings

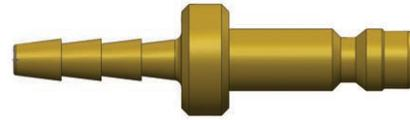
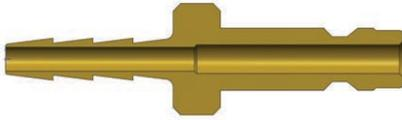

Body Size	A-Series Astronautics High Pressure Pneumatic Nipple (Hose Barb)											
	Part Detail			List Price	Length		Maximum OD		Hex Inch	Weight Lb	Package Qty	
	Part Number	Hose ID	Material		Inch	mm	Inch	mm			Bag	Box
1/8"	A1S1-B	1/8"	brass	\$7.82	1.50	38.1	0.44	11.2	-	0.02	10	100
1/4"	A2S2	1/4"	steel	10.22	1.99	50.5	1.01	25.7	-	0.04	10	100

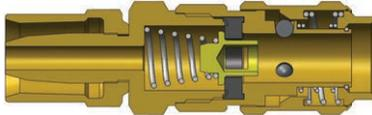

Body Size	A-Series Astronautics High Pressure Coupler (Reusable Barb)											
	Part Detail			List Price	Length		Maximum OD		Hex Inch	Weight Lb	Package Qty	
	Part Number	Hose ID x OD	Material		Inch	mm	Inch	mm			Bag	Box
1/4"	2AE2-B	1/4" x 1/2"	brass	\$33.80	2.62	66.5	0.77	19.6	11/16"	0.17	10	100

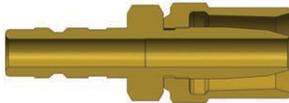

Body Size	A-Series Astronautics High Pressure Nipple (Reusable Barb)											
	Part Detail			List Price	Length		Maximum OD		Hex Inch	Weight Lb	Package Qty	
	Part Number	Hose ID x OD	Material		Inch	mm	Inch	mm			Bag	Box
1/4"	A2E2	1/4" x 1/2"	steel	\$11.69	1.97	50.0	0.68	17.3	9/16"	0.08	10	100
1/4"	A2E2-B	1/4" x 1/2"	brass	11.36	1.97	50.0	0.68	17.3	9/16"	0.08	10	100

### A Series Profile

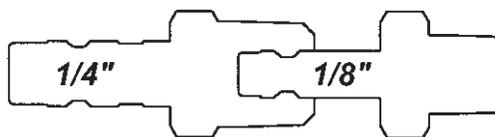

Operating pressure for couplings utilizing hose barb end connections may be dramatically reduced to that of the hose rating and/or hose end connection combination. Consult hose manufacturer's catalog for hose end connection ratings. If in doubt, test under controlled conditions for suitability to application. Dixon Quick Coupling cannot assume liability for misapplication of production resulting in equipment down-time, lost production, and/or personal injury including death.

# SCV-Series Pneumatic Couplings

## Interchange Data:

- Hansen FS-Series

## Materials:

- Machined components are manufactured using solid brass bar stock.
- Stainless steel springs and roll-pins maximize corrosion resistance and extend service life.

## Seal Components:

- Nitrile (Buna-N) seals are standard, providing a temperature range of -40°F to +250°F (-40°C to +121°C).

## Features:

- Does not prevent backflow
- High flow design results in maximum flow with minimal pressure drop.
- Automatically and instantly protects the operator against hose whip in the event of a damaged hose or coupling.
- In the event of a hose rupture or coupling failure, the valve will automatically reset after the problem is fixed.
- SCV-Series is available in a large selection of sizes ranging from 1/4" to 3", NPTF (BSPP/BSPT threads on request).
- Valve operation is fully compliant with OSHA Safety Regulation 1926.302(b)(7), as shown on page 3.



Not recommended for applications requiring 100% of the available air supply. These applications include, but are not limited to, sand blast equipment, pile driving rigs, and expansion joint blow down pipes. It is recommended to install auxiliary safety devices, including Safety Cables, to ensure optimum safety for the operator in the event of a coupling failure or hose rupture.

## Use:

- Safety check valves operate by using the pressure differential across the valve to operate the valve and spring assembly. The pressure differential is directly related to the flow of air (SCFM) through the valve.
- When the pressure differential is within the operating limits - below the cutoff flow - of the unit, the force on the valve exerted by the spring is greater than that caused by the pressure differential (see "Open Position" graphic on next page). The valve remains open and normal operation continues.
- When the pressure differential is above the cutoff limit, the force on the valve exerted by the pressure differential is greater than the force exerted by the spring, and the valve closes (see the "Closed Position" graphic on next page).
- After the repair is made, normal operation is automatically enabled when pressure across the valve equalizes through the bleeder hole.
- The valve spring size can be specified by determining the air flow during normal operation and by estimating the air flow if a failure or rupture occurs.

## Technical Specifications:

Performance Specifications	Maximum Operating Pressure - Bar (PSI)	Minimum Burst Pressure - Bar (PSI)	Air Flow * 30.5m (100')
1/4"	17 (250)	138 (2,000)	17 SCFM
3/8"	17 (250)	138 (2,000)	41 SCFM
1/2"	17 (250)	138 (2,000)	77 SCFM
3/4"	17 (250)	138 (2,000)	178 SCFM
1"	17 (250)	138 (2,000)	340 SCFM
1-1/4"	17 (250)	138 (2,000)	620 SCFM
1-1/2"	17 (250)	138 (2,000)	940 SCFM
2"	17 (250)	138 (2,000)	1,760 SCFM
2-1/2"	17 (250)	138 (1,500)	2,800 SCFM
3"	17 (250)	138 (1,200)	4,200 SCFM

\* Air flow rating is based upon calculated values using unobstructed air flow for the applicable hose size.

## SCV-Series Pneumatic Couplings

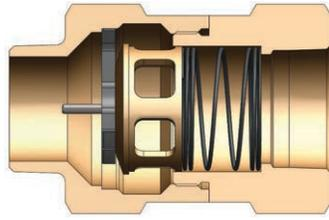

**Open**



**Closed**

Body Size	SCV-Series Excessive Flow Sensor (Male to Female Threads)							
	Part Detail			List Price	Cutoff Flow - SCFM (90 PSI Inlet Pressure)	Weight Lb	Package Qty	
	Part Number	Threads	Material				Bag	Box
1/4"	SCVL2	1/4" - 18 NPTF	brass	<b>\$62.58</b>	23-29	0.13	5	25
3/8"	SCVL3	3/8" - 18 NPTF	brass	<b>58.70</b>	30-36	0.19	5	25
3/8"	SCVM3	3/8" - 18 NPTF	brass	<b>58.70</b>	39-47	0.19	5	25
3/8"	SCVS3	3/8" - 18 NPTF	brass	<b>58.70</b>	52-65	0.19	5	25
1/2"	SCVM4	1/2" - 14 NPTF	brass	<b>63.03</b>	70-78	0.50	5	20
1/2"	SCVS4	1/2" - 14 NPTF	brass	<b>63.03</b>	80-96	0.50	5	20
3/4"	SCVL6	3/4" - 14 NPTF	brass	<b>99.76</b>	72-88	0.81	-	10
3/4"	SCVM6	3/4" - 14 NPTF	brass	<b>99.76</b>	92-108	0.81	-	10
3/4"	SCVR6	3/4" - 14 NPTF	brass	<b>99.76</b>	112-128	0.81	-	10
3/4"	SCVJ6	3/4" - 14 NPTF	brass	<b>99.76</b>	132-148	0.81	-	10
3/4"	SCVS6	3/4" - 14 NPTF	brass	<b>99.76</b>	160-180	0.81	-	10
3/4"	SCVH6	3/4" - 14 NPTF	brass	<b>99.76</b>	180-200	0.81	-	10
1"	SCVL8	1" - 11 1/2 NPTF	brass	<b>112.82</b>	165-195	1.50	-	5
1"	SCVM8	1" - 11 1/2 NPTF	brass	<b>112.82</b>	220-260	1.50	-	5
1"	SCVS8	1" - 11 1/2 NPTF	brass	<b>112.82</b>	280-320	1.50	-	5
1"	SCVH8	1" - 11 1/2 NPTF	brass	<b>112.82</b>	310-340	1.50	-	5
1-1/4"	SCVL10	1-1/4" - 11 1/2 NPTF	brass	<b>233.05</b>	260-290	2.19	-	5
1-1/4"	SCVM10	1-1/4" - 11 1/2 NPTF	brass	<b>233.05</b>	300-340	2.19	-	5
1-1/4"	SCVS10	1-1/4" - 11 1/2 NPTF	brass	<b>233.05</b>	440-500	2.19	-	5
1-1/4"	SCVH10	1-1/4" - 11 1/2 NPTF	brass	<b>233.05</b>	570-630	2.19	-	5
1-1/2"	SCVL12	1-1/2" - 11 1/2 NPTF	brass	<b>390.90</b>	300-360	5.00	-	1
1-1/2"	SCVM12	1-1/2" - 11 1/2 NPTF	brass	<b>390.90</b>	470-530	5.00	-	1
1-1/2"	SCVX12	1-1/2" - 11 1/2 NPTF	brass	<b>390.90</b>	564-602	5.00	-	1
1-1/2"	SCVS12	1-1/2" - 11 1/2 NPTF	brass	<b>390.90</b>	640-720	5.00	-	1
1-1/2"	SCVH12	1-1/2" - 11 1/2 NPTF	brass	<b>390.90</b>	750-830	5.00	-	1
2"	SCVL16	2" - 11 1/2 NPTF	brass	<b>533.79</b>	510-590	8.13	-	1
2"	SCVM16	2" - 11 1/2 NPTF	brass	<b>533.79</b>	725-825	8.13	-	1
2"	SCVS16	2" - 11 1/2 NPTF	brass	<b>533.79</b>	900-1050	8.13	-	1
2"	SCVH16	2" - 11 1/2 NPTF	brass	<b>533.79</b>	1100-1200	8.13	-	1
3"	SCVL24	3" - 11 1/2 NPTF	brass	<b>2266.67</b>	1200-1400	11.60	-	1
3"	SCVS24	3" - 11 1/2 NPTF	brass	<b>2266.67</b>	2400-2700	11.60	-	1
3"	SCVH24	3" - 11 1/2 NPTF	brass	<b>2266.67</b>	2850-3050	11.60	-	1

Contact Factory for cut-off flow values at other inlet pressures.

# H-Series Hydraulic Couplings

## Interchange Data:

- Interchangeable to ISO7241 Series 'B'
- Parker 60-Series, Snap-Tite 72-Series, Hansen HK-Series, Faster Series 'HNV' Aeroquip/Eaton FD45, Stucchi Series IRB/IRBO/IRBX

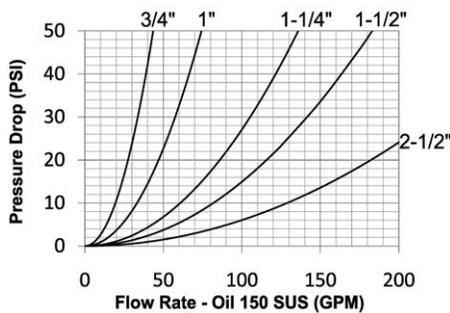
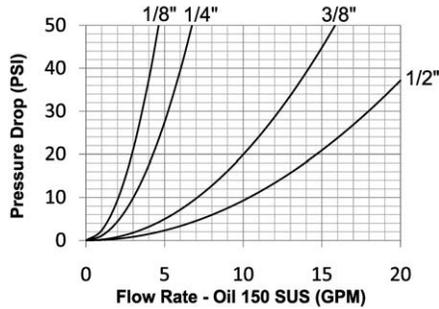

## Materials:

- Machined components are manufactured using solid steel, brass, 303 stainless steel or 316 stainless steel bar stock.
- Stainless steel balls, retaining rings, and springs maximize corrosion resistance and extend service life.
- Steel componentry is plated using ROHS Compliant Trivalent Chrome.
- Steel coupler sleeves are hardened to resist deformation and maximize service life.
- Steel nipples are hardened to provide heavy duty performance and resist brinelling.

## Seal Components:

- Nitrile (Buna-N) seals are standard providing a temperature range of -40°F to +250°F (-40°C to +121°C).
- 1/8" to 1" steel and stainless couplers have a PTFE anti-extrusion ring.
- 1/8" to 2-1/2" brass couplers have a redundant O-Ring sealing system (dual O-Rings/no PTFE back-up ring)
- 1-1/4" to 2-1/2" steel and stainless couplers have a redundant o-ring sealing system (dual O-Rings/no PTFE back-up ring)
- Valve seals are crimped in place to maintain integrity during excessive flow conditions and pressurized connection.

## Rated Pressure Chart:

Body Size	H-Series ISO-B Interchange (Connected)															
	Steel Coupler/Plug				Brass Coupler/Plug				303 Stainless Coupler/Plug				316 Stainless Coupler/Plug			
	Max. Working		Burst		Max. Working		Burst		Max. Working		Burst		Max. Working		Burst	
	PSI	Bar	PSI	Bar	PSI	Bar	PSI	Bar	PSI	Bar	PSI	Bar	PSI	Bar	PSI	Bar
1/8"	4,000	275	14,500	1,000	3,000	200	16,500	1,100	3,500	240	29,500	2,000	3,500	240	29,500	2,000
1/4"	5,000	345	22,500	1,550	3,000	200	15,000	1,000	3,500	240	31,500	2,150	3,500	240	33,000	2,200
3/8"	4,000	275	16,500	1,150	2,500	175	12,000	800	3,500	240	26,500	1,800	3,500	240	28,000	1,900
1/2"	4,000	275	16,000	1,100	2,500	175	11,500	750	3,500	240	27,500	1,900	3,500	240	22,000	1,500
3/4"	4,000	275	16,500	1,150	2,000	138	12,000	800	3,000	200	16,000	1,100	3,000	200	21,500	1,450
1"	4,000	275	16,000	1,100	1,500	100	8,500	600	2,000	138	15,000	1,000	2,000	138	15,000	1,000
1-1/4"	2,500	170	10,000	700	1,000	70	6,500	450	2,000	138	10,000	700	1,000	70	8,500	580
1-1/2"	2,500	170	12,500	850	1,000	70	6,500	450	1,500	100	8,500	580	1,000	70	7,000	480
2-1/2"	1,500	100	6,000	400	700	50	5,500	380	1,000	70	6,500	450	900	62	6,000	400

## H-Series Hydraulic Couplings

### Technical Specifications:

Body Size	Interchange Standards				Functional Parameters				
	U.S. Military	U.S. Government	International Standards	ANSI/NFPA Standards	Locking Ball Quantity	Air Inclusion	Fluid Loss	Vacuum Inch HG	Flow ΔP = 22 PSI
1/8"	-	-	ISO7241 'B'	B93.113M-B	8	0.6cc	0.3cc	27.4	3.1 GPM
1/4"	-	-	ISO7241 'B'	B93.113M-B	8	1.1cc	0.9cc	27.4	4.5 GPM
3/8"	-	-	ISO7241 'B'	B93.113M-B	9	2.6cc	1.8cc	27.4	12 GPM
1/2"	-	-	ISO7241 'B'	B93.113M-B	9	3.8cc	2.9cc	27.4	18 GPM
3/4"	-	-	ISO7241 'B'	B93.113M-B	12	10.8cc	9.7cc	27.4	29 GPM
1"	-	-	ISO7241 'B'	B93.113M-B	12	15.9cc	15.3cc	27.4	50 GPM
1-1/4"	-	-	ISO7241 'B'	B93.113M-B	12	30.0cc	45.0cc	N/R	90 GPM
1-1/2"	-	-	ISO7241 'B'	B93.113M-B	12	60.0cc	75.0cc	N/R	120 GPM
2-1/2"	-	-	ISO7241 'B'	B93.113M-B	15	N/A	N/A	N/R	195 GPM

### List Price Seal Option Adders:

Body Size	Standard Seal Options												Kalrez® Seal Options									
	FKM		EPDM		Steam-EP		FDA FKM		Mil-Nitrile		Fuel Nitrile		PTFE		Silicone		4079		6375		7075	
	Pre	Add \$	Pre	Add \$	Pre	Add \$	Pre	Add \$	Pre	Add \$	Pre	Add \$	Pre	Add \$	Pre	Add \$	Pre	Add \$	Pre	Add \$	Pre	Add \$
1/8"	F-	\$0.00	P-	\$2.60	PS-	N/A	D-	N/A	M-	N/A	JF-	N/A	TS-	N/A	S-	N/A	K4-	POR	K6-	POR	K7-	POR
1/4"	F-	.00	P-	3.00	PS-	\$3.25	D-	\$3.00	M-	\$2.50	JF-	\$2.90	TS-	POR	S-	\$3.10	K4-	POR	K6-	POR	K7-	POR
3/8"	F-	.00	P-	3.50	PS-	4.00	D-	3.50	M-	2.90	JF-	3.70	TS-	POR	S-	3.80	K4-	POR	K6-	POR	K7-	POR
1/2"	F-	.00	P-	4.00	PS-	4.40	D-	4.00	M-	3.60	JF-	3.80	TS-	POR	S-	4.30	K4-	POR	K6-	POR	K7-	POR
3/4"	F-	.00	P-	6.20	PS-	6.30	D-	6.20	M-	5.20	JF-	5.80	TS-	POR	S-	6.00	K4-	POR	K6-	POR	K7-	POR
1"	F-	.00	P-	7.60	PS-	8.00	D-	7.60	M-	6.80	JF-	6.90	TS-	POR	S-	7.60	K4-	POR	K6-	POR	K7-	POR
1 1/4"	F-	.00	P-	10.00	PS-	11.00	D-	10.00	M-	8.75	JF-	9.50	TS-	N/A	S-	10.00	K4-	POR	K6-	POR	K7-	POR
1 1/2"	F-	.00	P-	14.00	PS-	20.00	D-	14.00	M-	12.00	JF-	16.40	TS-	N/A	S-	15.00	K4-	POR	K6-	POR	K7-	POR
2 1/2"	F-	N/A	P-	N/A	PS-	N/A	D-	N/A	M-	N/A	JF-	N/A	TS-	N/A	S-	N/A	K4-	N/A	K6-	N/A	K7-	N/A

### List Price Option Adders:

Body Size	Valve Options										Sleeve Options						Treatments			
	Unvalved		Actuator*		Steel		Brass		303 SS		316 SS		Sleeve-Lock		Flanged		Sil-Flange		Oxy-Clean	
	Suf	Add \$	Suf	Add \$	Suf	Add \$	Suf	Add \$	Suf	Add \$	Suf	Add \$	Suf	Add \$	Suf	Add \$	Suf	Add \$	Suf	Add \$
1/8"	-E	-\$1.50	-VA	N/A	-ZV	\$0.00	-BV	\$0.00	-SV	N/A	SSV	N/A	-LS	\$4.80	-FS	N/A	FSB	N/A	-C1	\$12.00
1/4"	-E	-1.50	-VA	\$4.00	-ZV	.00	-BV	.00	-SV	\$1.85	SSV	\$2.60	-LS	4.80	-FS	\$6.20	FSB	N/A	-C1	12.00
3/8"	-E	-2.30	-VA	4.30	-ZV	.00	-BV	.00	-SV	2.45	SSV	2.70	-LS	4.80	-FS	7.30	FSB	N/A	-C1	12.00
1/2"	-E	-4.60	-VA	6.20	-ZV	.00	-BV	.00	-SV	4.30	SSV	4.80	-LS	4.80	-FS	8.20	FSB	\$11.90	-C1	14.00
3/4"	-E	-5.80	-VA	8.00	-ZV	.00	-BV	.00	-SV	5.65	SSV	6.00	-LS	6.00	-FS	9.10	FSB	N/A	-C1	14.00
1"	-E	-8.50	-VA	12.00	-ZV	.00	-BV	.00	-SV	7.50	SSV	8.80	-LS	9.80	-FS	11.60	FSB	N/A	-C1	16.00
1 1/4"	-E	-26.00	-VA	N/A	-ZV	.00	-BV	.00	-SV	27.50	SSV	32.55	-LS	10.50	-FS	N/A	FSB	N/A	-C1	20.00
1 1/2"	-E	-31.50	-VA	N/A	-ZV	.00	-BV	.00	-SV	36.60	SSV	38.20	-LS	10.50	-FS	N/A	FSB	N/A	-C1	20.00
2 1/2"	-E	N/A	-VA	N/A	-ZV	N/A	-BV	N/A	-SV	N/A	SSV	N/A	-LS	N/A	-FS	N/A	FSB	N/A	-C1	N/A

\* Brass Valve Actuator

# H-Series Hydraulic Couplings

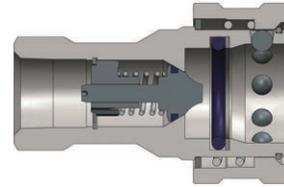

Body Size	H-Series ISO-B Interchange Coupler (Female Threads)											
	Part Detail			List Price	Length		Maximum OD		Hex Inch	Weight Lb	Package Qty	
	Part Number	Threads	Material		Inch	mm	Inch	mm			Bag	Box
1/8"	1HF1	1/8" - 27 NPTF	steel	\$24.33	1.90	48.3	0.93	23.6	9/16"	0.16	10	100
1/8"	1HF1-B	1/8" - 27 NPTF	brass	24.19	1.90	48.3	0.93	23.6	9/16"	0.16	10	100
1/8"	1HF1-S	1/8" - 27 NPTF	303 stainless	72.39	1.90	48.3	0.93	23.6	9/16"	0.16	10	100
1/8"	1HF1-SS	1/8" - 27 NPTF	316 stainless	134.75	1.90	48.3	0.93	23.6	9/16"	0.16	10	100
1/8"	1HOF2	7/16" - 20 ORB	steel	30.12	1.90	48.3	0.93	23.6	9/16"	0.16	10	100
1/4"	2HF2	1/4" - 18 NPTF	steel	23.16	2.26	57.4	1.12	28.4	7/8"	0.30	10	50
1/4"	2HF2-B	1/4" - 18 NPTF	brass	22.51	2.26	57.4	1.12	28.4	7/8"	0.32	10	50
1/4"	2HF2-S	1/4" - 18 NPTF	303 stainless	62.72	2.26	57.4	1.12	28.4	7/8"	0.30	10	50
1/4"	2HF2-SS	1/4" - 18 NPTF	316 stainless	150.98	2.26	57.4	1.12	28.4	3/4"	0.30	10	50
1/4"	2HBF2	1/4" - 19 BSPP	steel	25.48	2.26	57.4	1.12	28.4	7/8"	0.30	10	50
1/4"	2HBF2-B	1/4" - 19 BSPP	brass	24.76	2.26	57.4	1.12	28.4	7/8"	0.32	10	50
1/4"	2HBF2-S	1/4" - 19 BSPP	303 stainless	62.72	2.26	57.4	1.12	28.4	7/8"	0.30	10	50
1/4"	2HBF2-SS	1/4" - 19 BSPP	316 stainless	150.98	2.26	57.4	1.12	28.4	3/4"	0.30	10	50
1/4"	2HOF3	9/16" - 18 ORB	steel	27.80	2.26	57.4	1.12	28.4	13/16"	0.31	10	50
3/8"	3HF3	3/8" - 18 NPTF	steel	28.95	2.51	63.8	1.42	36.1	1-1/16"	0.40	10	50
3/8"	3HF3-B	3/8" - 18 NPTF	brass	31.29	2.51	63.8	1.42	36.1	1-1/16"	0.43	10	50
3/8"	3HF3-S	3/8" - 18 NPTF	303 stainless	88.13	2.51	63.8	1.42	36.1	1-1/16"	0.40	10	50
3/8"	3HF3-SS	3/8" - 18 NPTF	316 stainless	201.61	2.51	63.8	1.42	36.1	7/8"	0.40	10	50
3/8"	3HBF3	3/8" - 19 BSPP	steel	33.30	2.51	63.8	1.42	36.1	1-1/16"	0.40	10	50
3/8"	3HBF3-B	3/8" - 19 BSPP	brass	36.02	2.51	63.8	1.42	36.1	1-1/16"	0.43	10	50
3/8"	3HBF3-S	3/8" - 19 BSPP	303 stainless	88.13	2.51	63.8	1.42	36.1	1-1/16"	0.40	10	50
3/8"	3HBF3-SS	3/8" - 19 BSPP	316 stainless	201.61	2.51	63.8	1.42	36.1	7/8"	0.40	10	50
3/8"	3HOF4	3/4" - 16 ORB	steel	37.65	2.51	63.8	1.42	36.1	1"	0.51	10	50
1/2"	4HF4	1/2" - 14 NPTF	steel	36.48	2.86	72.6	1.86	47.2	1-5/16"	0.73	5	25
1/2"	4HF4-B	1/2" - 14 NPTF	brass	41.08	2.86	72.6	1.86	47.2	1-5/16"	0.80	5	25
1/2"	4HF4-S	1/2" - 14 NPTF	303 stainless	144.79	2.86	72.6	1.86	47.2	1-5/16"	0.75	5	25
1/2"	4HF4-SS	1/2" - 14 NPTF	316 stainless	282.72	2.86	72.6	1.86	47.2	1-1/16"	0.76	5	25
1/2"	4HBF4	1/2" - 14 BSPP	steel	45.38	2.86	72.6	1.86	47.2	1-5/16"	0.73	5	25
1/2"	4HBF4-B	1/2" - 14 BSPP	brass	47.66	2.86	72.6	1.86	47.2	1-5/16"	0.80	5	25
1/2"	4HBF4-S	1/2" - 14 BSPP	303 stainless	144.79	2.86	72.6	1.86	47.2	1-5/16"	0.75	5	25
1/2"	4HBF4-SS	1/2" - 14 BSPP	316 stainless	318.81	2.86	72.6	1.86	47.2	1-1/16"	0.76	5	25
1/2"	4HOF5	7/8" - 14 ORB	steel	48.65	2.86	72.6	1.86	47.2	1-1/8"	0.78	5	25
3/4"	6HF6	3/4" - 14 NPTF	steel	58.75	3.55	90.2	2.22	56.4	1-5/16"	1.30	-	10
3/4"	6HF6-B	3/4" - 14 NPTF	brass	80.03	3.55	90.2	2.22	56.4	1-5/16"	1.36	-	10
3/4"	6HF6-S	3/4" - 14 NPTF	303 stainless	227.26	3.55	90.2	2.22	56.4	1-5/16"	1.31	-	10
3/4"	6HF6-SS	3/4" - 14 NPTF	316 stainless	427.09	3.55	90.2	2.22	56.4	1-5/16"	1.33	-	10
3/4"	6HBF6	3/4" - 14 BSPP	steel	69.49	3.55	90.2	2.22	56.4	1-5/16"	1.30	-	10
3/4"	6HBF6-B	3/4" - 14 BSPP	brass	87.79	3.55	90.2	2.22	56.4	1-5/16"	1.36	-	10
3/4"	6HBF6-S	3/4" - 14 BSPP	303 stainless	227.26	3.55	90.2	2.22	56.4	1-5/16"	1.31	-	10
3/4"	6HBF6-SS	3/4" - 14 BSPP	316 stainless	504.53	3.55	90.2	2.22	56.4	1-5/16"	1.33	-	10
3/4"	6HOF6	1-1/16" - 12 ORB	steel	75.20	3.55	90.2	2.22	56.4	1-5/16"	1.39	-	10
1"	8HF8	1" - 11 1/2 NPTF	steel	97.08	4.13	104.9	2.49	63.2	1-5/8"	1.95	-	10
1"	8HF8-B	1" - 11 1/2 NPTF	brass	110.20	4.13	104.9	2.49	63.2	1-5/8"	1.99	-	10
1"	8HF8-S	1" - 11 1/2 NPTF	303 stainless	362.87	4.13	104.9	2.49	63.2	1-5/8"	1.95	-	10
1"	8HF8-SS	1" - 11 1/2 NPTF	316 stainless	649.66	4.13	104.9	2.49	63.2	1-5/8"	1.95	-	10
1"	8HBF8	1" - 11 BSPP	steel	97.08	4.13	104.9	2.49	63.2	1-5/8"	1.95	-	10
1"	8HBF8-B	1" - 11 BSPP	brass	110.20	4.13	104.9	2.49	63.2	1-5/8"	1.99	-	10
1"	8HBF8-S	1" - 11 BSPP	303 stainless	362.87	4.13	104.9	2.49	63.2	1-5/8"	1.95	-	10
1"	8HBF8-SS	1" - 11 BSPP	316 stainless	649.66	4.13	104.9	2.49	63.2	1-5/8"	1.95	-	10
1"	8HOF8	1-5/16" - 12 ORB	steel	110.03	4.13	104.9	2.49	63.2	1-5/8"	1.95	-	10



## H-Series Hydraulic Couplings

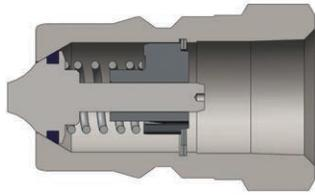

Body Size	H-Series ISO-B Interchange Nipple (Female Threads)											
	Part Detail			List Price	Length		Maximum OD		Hex Inch	Weight Lb	Package Qty	
	Part Number	Threads	Material		Inch	mm	Inch	mm			Bag	Box
1/8"	H1F1	1/8" - 27 NPTF	steel	\$9.85	1.28	32.5	0.65	16.5	9/16"	0.03	10	100
1/8"	H1F1-B	1/8" - 27 NPTF	brass	9.57	1.28	32.5	0.65	16.5	9/16"	0.04	10	100
1/8"	H1F1-S	1/8" - 27 NPTF	303 stainless	23.16	1.28	32.5	0.65	16.5	9/16"	0.03	10	100
1/8"	H1F1-SS	1/8" - 27 NPTF	316 stainless	57.75	1.28	32.5	0.65	16.5	9/16"	0.03	10	100
1/8"	H1OF2	7/16" - 20 ORB	steel	12.16	1.28	32.5	0.65	16.5	9/16"	0.05	10	100
1/4"	H2F2	1/4" - 18 NPTF	steel	10.95	1.55	39.4	0.83	21.1	3/4"	0.08	10	50
1/4"	H2F2-B	1/4" - 18 NPTF	brass	10.64	1.55	39.4	0.83	21.1	3/4"	0.09	10	50
1/4"	H2F2-S	1/4" - 18 NPTF	303 stainless	26.14	1.55	39.4	0.83	21.1	3/4"	0.08	10	50
1/4"	H2F2-SS	1/4" - 18 NPTF	316 stainless	69.34	1.55	39.4	0.83	21.1	3/4"	0.08	10	50
1/4"	H2BF2	1/4" - 19 BSPP	steel	12.74	1.55	39.4	0.83	21.1	3/4"	0.08	10	50
1/4"	H2BF2-B	1/4" - 19 BSPP	brass	12.38	1.55	39.4	0.83	21.1	3/4"	0.09	10	50
1/4"	H2BF2-S	1/4" - 19 BSPP	303 stainless	26.14	1.55	39.4	0.83	21.1	3/4"	0.08	10	50
1/4"	H2BF2-SS	1/4" - 19 BSPP	316 stainless	69.34	1.55	39.4	0.83	21.1	3/4"	0.08	10	50
1/4"	H2OF3	9/16" - 18 ORB	steel	12.98	1.61	40.9	0.90	22.9	13/16"	0.10	10	50
3/8"	H3F3	3/8" - 18 NPTF	steel	13.20	1.70	43.2	0.97	24.6	7/8"	0.12	10	50
3/8"	H3F3-B	3/8" - 18 NPTF	brass	15.76	1.70	43.2	0.97	24.6	7/8"	0.10	10	50
3/8"	H3F3-S	3/8" - 18 NPTF	303 stainless	42.95	1.70	43.2	0.97	24.6	7/8"	0.12	10	50
3/8"	H3F3-SS	3/8" - 18 NPTF	316 stainless	102.32	1.70	43.2	0.97	24.6	7/8"	0.12	10	50
3/8"	H3BF3	3/8" - 19 BSPP	steel	16.68	1.70	43.2	0.97	24.6	7/8"	0.12	10	50
3/8"	H3BF3-B	3/8" - 19 BSPP	brass	19.14	1.70	43.2	0.97	24.6	7/8"	0.10	10	50
3/8"	H3BF3-S	3/8" - 19 BSPP	303 stainless	42.95	1.70	43.2	0.97	24.6	7/8"	0.12	10	50
3/8"	H3BF3-SS	3/8" - 19 BSPP	316 stainless	102.32	1.70	43.2	0.97	24.6	7/8"	0.12	10	50
3/8"	H3OF4	3/4" - 16 ORB	steel	22.01	1.79	45.5	1.10	27.9	1"	0.16	10	50
1/2"	H4F4	1/2" - 14 NPTF	steel	14.36	1.94	49.3	1.17	29.7	1-1/16"	0.24	5	25
1/2"	H4F4-B	1/2" - 14 NPTF	brass	18.57	1.94	49.3	1.17	29.7	1-1/16"	0.25	5	25
1/2"	H4F4-S	1/2" - 14 NPTF	303 stainless	68.05	1.94	49.3	1.17	29.7	1-1/16"	0.24	5	25
1/2"	H4F4-SS	1/2" - 14 NPTF	316 stainless	132.33	1.94	49.3	1.17	29.7	1-1/16"	0.24	5	25
1/2"	H4BF4	1/2" - 14 BSPP	steel	18.44	1.94	49.3	1.17	29.7	1-1/16"	0.24	5	25
1/2"	H4BF4-B	1/2" - 14 BSPP	brass	18.57	1.94	49.3	1.17	29.7	1-1/16"	0.25	5	25
1/2"	H4BF4-S	1/2" - 14 BSPP	303 stainless	70.08	1.94	49.3	1.17	29.7	1-1/16"	0.24	5	25
1/2"	H4BF4-SS	1/2" - 14 BSPP	316 stainless	149.03	1.94	49.3	1.17	29.7	1-1/16"	0.24	5	25
1/2"	H4OF5	7/8" - 14 ORB	steel	24.33	1.94	49.3	1.24	31.5	1-1/8"	0.27	5	25
3/4"	H6F6	3/4" - 14 NPTF	steel	28.38	2.41	61.2	1.44	36.6	1-5/16"	0.46	-	10
3/4"	H6F6-B	3/4" - 14 NPTF	brass	31.58	2.41	61.2	1.44	36.6	1-5/16"	0.50	-	10
3/4"	H6F6-S	3/4" - 14 NPTF	303 stainless	103.67	2.41	61.2	1.44	36.6	1-5/16"	0.46	-	10
3/4"	H6F6-SS	3/4" - 14 NPTF	316 stainless	186.47	2.41	61.2	1.44	36.6	1-5/16"	0.45	-	10
3/4"	H6BF6	3/4" - 14 BSPP	steel	33.59	2.41	61.2	1.44	36.6	1-5/16"	0.46	-	10
3/4"	H6BF6-B	3/4" - 14 BSPP	brass	36.98	2.41	61.2	1.44	36.6	1-5/16"	0.50	-	10
3/4"	H6BF6-S	3/4" - 14 BSPP	303 stainless	103.67	2.41	61.2	1.44	36.6	1-5/16"	0.46	-	10
3/4"	H6BF6-SS	3/4" - 14 BSPP	316 stainless	250.45	2.41	61.2	1.44	36.6	1-5/16"	0.45	-	10
3/4"	H6OF6	1-1/16" - 12 ORB	steel	37.07	2.41	61.2	1.44	36.6	1-5/16"	0.46	-	10
1"	H8F8	1" - 11 1/2 NPTF	steel	40.54	2.87	72.9	1.79	45.5	1-5/8"	0.76	-	10
1"	H8F8-B	1" - 11 1/2 NPTF	brass	48.40	2.87	72.9	1.79	45.5	1-5/8"	0.76	-	10
1"	H8F8-S	1" - 11 1/2 NPTF	303 stainless	164.21	2.87	72.9	1.79	45.5	1-5/8"	0.76	-	10
1"	H8F8-SS	1" - 11 1/2 NPTF	316 stainless	294.75	2.87	72.9	1.79	45.5	1-5/8"	0.76	-	10
1"	H8BF8	1" - 11 BSPP	steel	44.01	2.87	72.9	1.79	45.5	1-5/8"	0.76	-	10
1"	H8BF8-B	1" - 11 BSPP	brass	51.78	2.87	72.9	1.79	45.5	1-5/8"	0.76	-	10
1"	H8BF8-S	1" - 11 BSPP	303 stainless	179.54	2.87	72.9	1.79	45.5	1-5/8"	0.77	-	10
1"	H8BF8-SS	1" - 11 BSPP	316 stainless	358.51	2.87	72.9	1.79	45.5	1-5/8"	0.76	-	10
1"	H8OF8	1-5/16" - 12 ORB	steel	67.76	2.87	72.9	1.79	45.5	1-5/8"	0.80	-	10

## H-Series Hydraulic Couplings

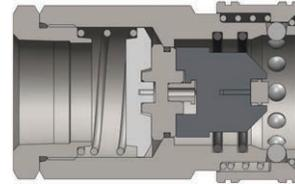

Body Size	H-Series ISO-B High Volume Interchange Coupler (Female Threads)											
	Part Detail			List Price	Length		Maximum OD		Hex Inch	Weight Lb	Package Qty	
	Part Number	Threads	Material		Inch	mm	Inch	mm			Bag	Box
1-1/4"	10HF10	1-1/4" - 11 1/2 NPTF	steel	<b>\$452.45</b>	4.50	114.3	2.60	66.0	2-3/8"	3.50	-	1
1-1/4"	10HF10-B	1-1/4" - 11 1/2 NPTF	brass	<b>360.40</b>	4.50	114.3	2.60	66.0	2-3/8"	3.50	-	1
1-1/4"	10HF10-S	1-1/4" - 11 1/2 NPTF	303 stainless	<b>866.73</b>	4.50	114.3	2.60	66.0	2-3/8"	3.51	-	1
1-1/4"	10HBF10	1-1/4" - 11 BSPP	steel	<b>463.31</b>	4.50	114.3	2.60	66.0	2-3/8"	3.50	-	1
1-1/2"	12HF10	1-1/4" - 11 1/2 NPTF	steel	<b>434.84</b>	4.81	122.2	3.00	76.2	2-5/8"	4.70	-	1
1-1/2"	12HF10-B	1-1/4" - 11 1/2 NPTF	brass	<b>545.87</b>	4.81	122.2	3.00	76.2	2-5/8"	4.68	-	1
1-1/2"	12HF10-S	1-1/4" - 11 1/2 NPTF	303 stainless	<b>1338.98</b>	4.81	122.2	3.00	76.2	2-5/8"	4.68	-	1
1-1/2"	12HOF10	1-5/8" - 12 ORB	steel	<b>517.07</b>	4.81	122.2	3.00	76.2	2-5/8"	4.72	-	1
1-1/2"	12HF12	1-1/2" - 11 1/2 NPTF	steel	<b>434.84</b>	4.81	122.2	3.00	76.2	2-5/8"	4.70	-	1
1-1/2"	12HF12-B	1-1/2" - 11 1/2 NPTF	brass	<b>438.94</b>	4.81	122.2	3.00	76.2	2-5/8"	4.58	-	1
1-1/2"	12HF12-S	1-1/2" - 11 1/2 NPTF	303 stainless	<b>1216.20</b>	4.81	122.2	3.00	76.2	2-5/8"	4.68	-	1
1-1/2"	12HF12-SS	1-1/2" - 11 1/2 NPTF	316 stainless	<b>2647.44</b>	4.81	122.2	3.00	76.2	2-5/8"	4.68	-	1
1-1/2"	12HBF12	1-1/2" - 11 BSPP	steel	<b>422.17</b>	4.81	122.2	3.00	76.2	2-5/8"	4.70	-	1
1-1/2"	12HBF12-B	1-1/2" - 11 BSPP	brass	<b>529.98</b>	4.81	122.2	3.00	76.2	2-5/8"	4.58	-	1
1-1/2"	12HBF12-S	1-1/2" - 11 BSPP	303 stainless	<b>1338.98</b>	4.81	122.2	3.00	76.2	2-5/8"	4.68	-	1
1-1/2"	12HBF12-SS	1-1/2" - 11 BSPP	316 stainless	<b>2647.45</b>	4.81	122.2	3.00	76.2	2-5/8"	4.68	-	1
1-1/2"	12HOF12	1-7/8" - 12 ORB	steel	<b>517.07</b>	4.81	122.2	3.00	76.2	2-5/8"	4.72	-	1
2-1/2"	20HF16	2" - 11 1/2 NPTF	steel	<b>1162.51</b>	5.57	141.5	4.10	104.1	3-3/4"	11.03	-	1
2-1/2"	20HF16-B	2" - 11 1/2 NPTF	brass	<b>1064.66</b>	5.57	141.5	4.10	104.1	3-3/4"	11.09	-	1
2-1/2"	20HF20	2 1/2" - 8 NPTF	steel	<b>1156.51</b>	6.04	153.4	4.10	104.1	3-3/4"	11.13	-	1
2-1/2"	20HF24	3" - 8 NPTF	steel	<b>1213.41</b>	6.96	176.8	4.35	110.5	4"	11.51	-	1

## H-Series Hydraulic Couplings

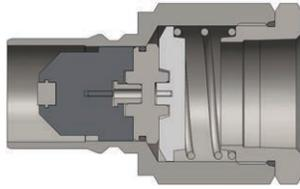

Body Size	H-Series ISO-B High Volume Interchange Nipple (Female Threads)											
	Part Detail			List Price	Length		Maximum OD		Hex Inch	Weight Lb	Package Qty	
	Part Number	Threads	Material		Inch	mm	Inch	mm			Bag	Box
1-1/4"	H10F10	1-1/4" - 11 1/2 NPTF	steel	<b>\$329.04</b>	4.25	108.0	2.60	66.0	2-3/8"	2.19	-	1
1-1/4"	H10F10-B	1-1/4" - 11 1/2 NPTF	brass	<b>268.86</b>	4.25	108.0	2.60	66.0	2-3/8"	2.19	-	1
1-1/4"	H10F10-S	1-1/4" - 11 1/2 NPTF	303 stainless	<b>675.78</b>	4.25	108.0	2.60	66.0	2-3/8"	2.19	-	1
1-1/4"	H10BF10	1-1/4" - 11 BSPP	steel	<b>376.44</b>	4.25	108.0	2.60	66.0	2-3/8"	2.19	-	1
1-1/2"	H12F10	1-1/4" - 11 1/2 NPTF	steel	<b>370.66</b>	4.76	120.9	2.88	73.2	2-5/8"	3.10	-	1
1-1/2"	H12F10-B	1-1/4" - 11 1/2 NPTF	brass	<b>335.40</b>	4.76	120.9	2.88	73.2	2-5/8"	3.10	-	1
1-1/2"	H12F10-S	1-1/4" - 11 1/2 NPTF	303 stainless	<b>926.63</b>	4.76	120.9	2.88	73.2	2-5/8"	3.10	-	1
1-1/2"	H12OF10	1-5/8" - 12 ORB	steel	<b>368.79</b>	4.76	120.9	2.88	73.2	2-5/8"	3.15	-	1
1-1/2"	H12F12	1-1/2" - 11 1/2 NPTF	steel	<b>370.66</b>	4.76	120.9	2.88	73.2	2-5/8"	3.10	-	1
1-1/2"	H12F12-B	1-1/2" - 11 1/2 NPTF	brass	<b>335.40</b>	4.76	120.9	2.88	73.2	2-5/8"	2.96	-	1
1-1/2"	H12F12-S	1-1/2" - 11 1/2 NPTF	303 stainless	<b>926.63</b>	4.76	120.9	2.88	73.2	2-5/8"	3.06	-	1
1-1/2"	H12F12-SS	1-1/2" - 11 1/2 NPTF	316 stainless	<b>1788.09</b>	4.76	120.9	2.88	73.2	2-5/8"	3.05	-	1
1-1/2"	H12BF12	1-1/2" - 11 BSPP	steel	<b>380.19</b>	4.76	120.9	2.88	73.2	2-5/8"	3.10	-	1
1-1/2"	H12BF12-B	1-1/2" - 11 BSPP	brass	<b>335.40</b>	4.76	120.9	2.88	73.2	2-5/8"	2.96	-	1
1-1/2"	H12BF12-S	1-1/2" - 11 BSPP	303 stainless	<b>926.63</b>	4.76	120.9	2.88	73.2	2-5/8"	3.06	-	1
1-1/2"	H12BF12-SS	1-1/2" - 11 BSPP	316 stainless	<b>1788.09</b>	4.76	120.9	2.88	73.2	2-5/8"	3.05	-	1
1-1/2"	H12OF12	1-7/8" - 12 ORB	steel	<b>368.79</b>	4.76	120.9	2.88	73.2	2-5/8"	3.15	-	1
2-1/2"	H20F16	2" - 11 1/2 NPTF	steel	<b>918.41</b>	5.48	139.2	4.10	104.1	3-3/4"	7.34	-	1
2-1/2"	H20F16-B	2" - 11 1/2 NPTF	brass	<b>806.71</b>	5.48	139.2	4.10	104.1	3-3/4"	7.35	-	1
2-1/2"	H20F20	2-1/2" - 8 NPTF	steel	<b>907.25</b>	5.95	151.1	4.10	104.1	3-3/4"	7.22	-	1
2-1/2"	H20F24	3" - 8 NPTF	steel	<b>957.65</b>	6.87	174.5	4.35	110.5	4"	7.56	-	1

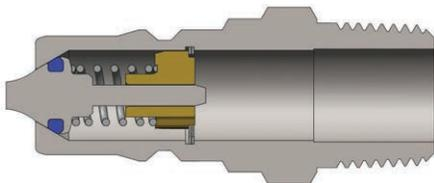

Body Size	H-Series ISO-B Interchange Nipple (Male Threads)											
	Part Detail			List Price	Length		Maximum OD		Hex Inch	Weight Lb	Package Qty	
	Part Number	Threads	Material		Inch	mm	Inch	mm			Bag	Box
1/4"	H2M3	3/8" - 18 NPTF	steel	<b>\$14.96</b>	2.03	51.6	0.83	21.1	3/4"	0.09	1	50
1/2"	H4M6-S	3/4" - 14 NPTF	303 stainless	<b>100.65</b>	2.13	58.7	1.17	29.7	1-1/16"	0.50	-	10

## H-Series Hydraulic Couplings

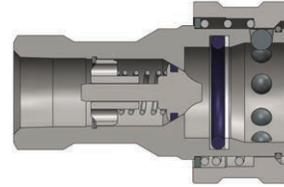

Body Size	H-Series ISO-B Steel Mill 'Slide Gate' Coupler (Female Threads)											
	Part Detail			List Price	Length		Maximum OD		Hex Inch	Weight Lb	Package Qty	
	Part Number	Threads	Material		Inch	mm	Inch	mm			Bag	Box
1/2"	4HF4-HV	1/2" - 14 NPTF	steel	\$58.89	2.86	72.6	1.86	47.2	1-1/16"	0.80	5	25

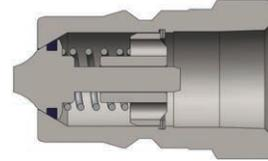

Body Size	H-Series ISO-B Steel Mill 'Slide Gate' Nipple (Female Threads)											
	Part Detail			List Price	Length		Maximum OD		Hex Inch	Weight Lb	Package Qty	
	Part Number	Threads	Material		Inch	mm	Inch	mm			Bag	Box
1/2"	H4F4-HV	1/2" - 14 NPTF	steel	\$23.49	1.94	49.3	1.17	29.7	1-1/16"	0.28	5	25

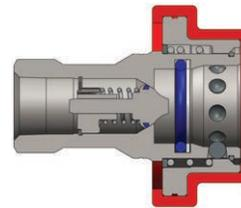

Body Size	H-Series ISO-B Food Grade Silicone Flanged Coupler (Female Threads)											
	Part Detail			List Price	Length		Maximum OD		Hex Inch	Weight Lb	Package Qty	
	Part Number	Threads	Material		Inch	mm	Inch	mm			Bag	Box
1/2"	D-4HF4-S-FSB	1/2" - 14 NPTF	303 stainless	\$155.57	2.86	72.6	2.52	64.0	1-1/16"	0.75	5	25
1/2"	D-4HF4-SS-FSB	1/2" - 14 NPTF	316 stainless	309.71	2.86	72.6	2.52	64.0	1-1/16"	0.75	5	25

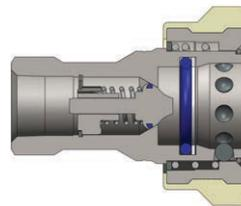
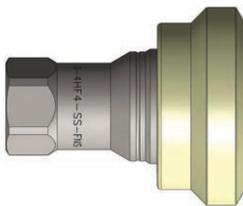

Body Size	H-Series ISO-B Food Grade Nylon Flanged Coupler (Female Threads)											
	Part Detail			List Price	Length		Maximum OD		Hex Inch	Weight Lb	Package Qty	
	Part Number	Threads	Material		Inch	mm	Inch	mm			Bag	Box
1/2"	D-4HF4-S-FNS	1/2" - 14 NPTF	303 stainless	\$157.54	2.86	72.6	2.38	60.5	1-1/16"	0.75	5	25
1/2"	D-4HF4-SS-FNS	1/2" - 14 NPTF	316 stainless	295.77	2.86	72.6	2.38	60.5	1-1/16"	0.75	5	25

## H-Series Hydraulic Couplings

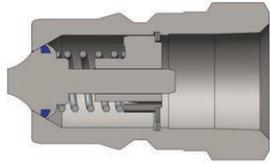

Body Size	H-Series ISO-B Food Grade Nipple (Female Threads)											
	Part Detail			List Price	Length		Maximum OD		Hex Inch	Weight Lb	Package Qty	
	Part Number	Threads	Material		Inch	mm	Inch	mm			Bag	Box
1/2"	D-H4F4-SV-8	1/2" - 14 NPTF	steel	<b>\$31.36</b>	1.94	49.3	1.17	29.7	1-1/16"	0.20	5	25
1/2"	D-H4F4-S	1/2" - 14 NPTF	303 stainless	<b>70.09</b>	1.94	49.3	1.17	29.7	1-1/16"	0.24	5	25
1/2"	D-H4F4-SS	1/2" - 14 NPTF	316 stainless	<b>134.33</b>	1.94	49.3	1.17	29.7	1-1/16"	0.24	5	25



Body Size	H-Series ISO-B Interchange Dust Caps and Plugs					
	Part Detail			List Price	Package Qty	
	Coupler Dust Plug	Nipple Dust Cap	Material		Bag	Box
1/8"	1HDP	H1DC	Nitrile	<b>\$3.16</b>	10	100
1/4"	2HDP-H2DC combo plug/cap		Nitrile	<b>3.16</b>	10	50
3/8"	3HDP-H3DC combo plug/cap		Nitrile	<b>3.51</b>	10	50
1/2"	4HDP-H4DC combo plug/cap		Nitrile	<b>3.80</b>	10	50
3/4"	6HDP-H6DC combo plug/cap		Nitrile	<b>8.52</b>	5	25
1"	8HDP-H8DC* combo plug/cap		Nitrile	<b>9.79</b>	5	25

\* 8HDP-H8DC fits both 1" and 1-1/4" body sizes

## H-Series Hydraulic Couplings



Body Size	H-Series ISO-B Interchange Coupler Rigid Dust Plug						
	Part Detail			List Price	Weight Lb	Package Qty	
	Part Number	Lanyard	Body			Bag	Box
1/4"	2HDP-A	SS bead chain	aluminum	<b>\$12.80</b>	0.02	10	50
3/8"	3HDP-A	SS bead chain	aluminum	<b>14.07</b>	0.02	10	50
1/2"	4HDP-A	SS bead chain	aluminum	<b>16.33</b>	0.03	10	50
3/4"	6HDP-A	SS bead chain	aluminum	<b>22.57</b>	0.09	5	25
1"	8HDP-A	SS bead chain	aluminum	<b>52.18</b>	0.14	5	25
1-1/2"	12HDP-A	SS bead chain	aluminum	<b>52.18</b>	0.29	-	10
2-1/2"	20HDP-A	SS chain	aluminum	<b>232.52</b>	0.42	-	5



Body Size	H-Series ISO-B Interchange Nipple Rigid Dust Cap						
	Part Detail			List Price	Weight Lb	Package Qty	
	Part Number	Lanyard	Body			Bag	Box
1/4"	H2DC-A	SS bead chain	aluminum	<b>\$12.80</b>	0.03	10	50
3/8"	H3DC-A	SS bead chain	aluminum	<b>14.07</b>	0.07	10	50
1/2"	H4DC-A	SS bead chain	aluminum	<b>16.33</b>	0.13	10	50
3/4"	H6DC-A	SS bead chain	aluminum	<b>23.35</b>	0.19	5	25
1"	H8DC-A	SS bead chain	aluminum	<b>56.30</b>	0.26	5	25
1-1/2"	H12DC-A	SS bead chain	aluminum	<b>58.16</b>	0.25	-	10
2-1/2"	H20DC-A	SS chain	aluminum	<b>239.57</b>	0.40	-	5

### H Series Profile

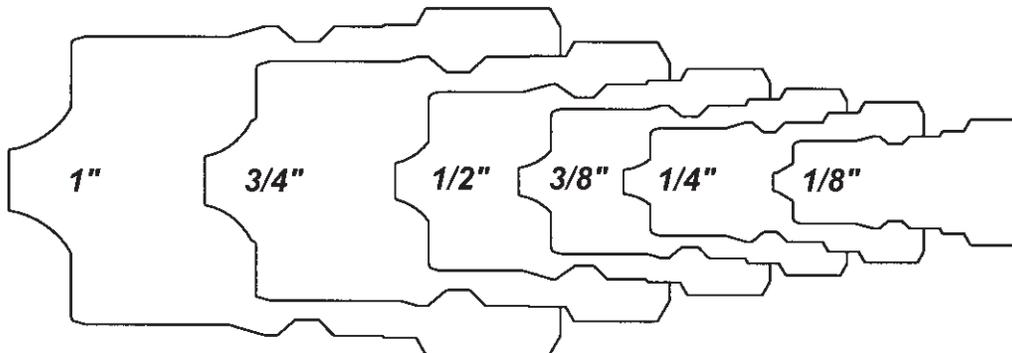

## H-Series Hydraulic Couplings

Body Size	H-Series ISO-B Coupler Seal Kits							
	Part Detail			List Price	Seal Kit Contents	Package Qty		
	Part Number	Coupler Style	Seal Material			Bag	Box	
1/8"	1H-SKIT	steel, 303 SS, 316 SS	Nitrile	<b>\$2.21</b>	O-Ring and PTFE Anti-Extrusion Ring	25	200	
1/8"	1H-BSKIT	brass	Nitrile	<b>2.13</b>	Two O-Rings	25	200	
1/8"	F-1H-SKIT	steel, 303 SS, 316 SS	FKM	<b>4.01</b>	O-Ring and PTFE Anti-Extrusion Ring	25	200	
1/8"	F-1H-BSKIT	brass	FKM	<b>3.77</b>	Two O-Rings	25	200	
1/8"	P-1H-SKIT	steel, 303 SS, 316 SS	EPDM	<b>3.02</b>	O-Ring and PTFE Anti-Extrusion Ring	25	200	
1/8"	P-1H-BSKIT	brass	EPDM	<b>2.81</b>	Two O-Rings	25	200	
1/4"	2H-SKIT	steel, 303 SS, 316 SS	Nitrile	<b>4.39</b>	O-Ring and PTFE Anti-Extrusion Ring	25	200	
1/4"	2H-BSKIT	brass	Nitrile	<b>4.13</b>	Two O-Rings	25	200	
1/4"	F-2H-SKIT	steel, 303 SS, 316 SS	FKM	<b>6.40</b>	O-Ring and PTFE Anti-Extrusion Ring	25	200	
1/4"	F-2H-BSKIT	brass	FKM	<b>6.02</b>	Two O-Rings	25	200	
1/4"	P-2H-SKIT	steel, 303 SS, 316 SS	EPDM	<b>5.99</b>	O-Ring and PTFE Anti-Extrusion Ring	25	200	
1/4"	P-2H-BSKIT	brass	EPDM	<b>5.64</b>	Two O-Rings	25	200	
3/8"	3H-SKIT	steel, 303 SS, 316 SS	Nitrile	<b>4.60</b>	O-Ring and PTFE Anti-Extrusion Ring	25	200	
3/8"	3H-BSKIT	brass	Nitrile	<b>4.33</b>	Two O-Rings	25	200	
3/8"	F-3H-SKIT	steel, 303 SS, 316 SS	FKM	<b>6.80</b>	O-Ring and PTFE Anti-Extrusion Ring	25	200	
3/8"	F-3H-BSKIT	brass	FKM	<b>6.40</b>	Two O-Rings	25	200	
3/8"	P-3H-SKIT	steel, 303 SS, 316 SS	EPDM	<b>6.40</b>	O-Ring and PTFE Anti-Extrusion Ring	25	200	
3/8"	P-3H-BSKIT	brass	EPDM	<b>6.02</b>	Two O-Rings	25	200	
1/2"	4H-SKIT	steel, 303 SS, 316 SS	Nitrile	<b>5.42</b>	O-Ring and PTFE Anti-Extrusion Ring	25	200	
1/2"	4H-BSKIT	brass	Nitrile	<b>5.05</b>	Two O-Rings	25	200	
1/2"	F-4H-SKIT	steel, 303 SS, 316 SS	FKM	<b>7.81</b>	O-Ring and PTFE Anti-Extrusion Ring	25	200	
1/2"	F-4H-BSKIT	brass	FKM	<b>7.33</b>	Two O-Rings	25	200	
1/2"	P-4H-SKIT	steel, 303 SS, 316 SS	EPDM	<b>7.42</b>	O-Ring and PTFE Anti-Extrusion Ring	25	200	
1/2"	P-4H-BSKIT	brass	EPDM	<b>6.96</b>	Two O-Rings	25	200	
3/4"	6H-SKIT	steel, 303 SS, 316 SS	Nitrile	<b>7.42</b>	O-Ring and PTFE Anti-Extrusion Ring	25	200	
3/4"	6H-BSKIT	brass	Nitrile	<b>6.96</b>	Two O-Rings	25	200	
3/4"	F-6H-SKIT	steel, 303 SS, 316 SS	FKM	<b>10.00</b>	O-Ring and PTFE Anti-Extrusion Ring	25	200	
3/4"	F-6H-BSKIT	brass	FKM	<b>9.40</b>	Two O-Rings	25	200	
3/4"	P-6H-SKIT	steel, 303 SS, 316 SS	EPDM	<b>9.61</b>	O-Ring and PTFE Anti-Extrusion Ring	25	200	
3/4"	P-6H-BSKIT	brass	EPDM	<b>9.02</b>	Two O-Rings	25	200	
1"	8H-SKIT	steel, 303 SS, 316 SS	Nitrile	<b>9.42</b>	O-Ring and PTFE Anti-Extrusion Ring	25	200	
1"	8H-BSKIT	brass	Nitrile	<b>8.84</b>	Two O-Rings	25	200	
1"	F-8H-SKIT	steel, 303 SS, 316 SS	FKM	<b>12.22</b>	O-Ring and PTFE Anti-Extrusion Ring	25	200	
1"	F-8H-BSKIT	brass	FKM	<b>11.45</b>	Two O-Rings	25	200	
1"	P-8H-SKIT	steel, 303 SS, 316 SS	EPDM	<b>11.78</b>	O-Ring and PTFE Anti-Extrusion Ring	25	200	
1"	P-8H-BSKIT	brass	EPDM	<b>11.08</b>	Two O-Rings	25	200	
1-1/4"	10H-SKIT	all	Nitrile	<b>11.31</b>	Adapter/Valve O-Ring & Two Body O-Rings	10	50	
1-1/4"	F-10-SKIT	all	FKM	<b>13.79</b>	Adapter/Valve O-Ring & Two Body O-Rings	10	50	
1-1/4"	P-10-SKIT	all	EPDM	<b>13.37</b>	Adapter/Valve O-Ring & Two Body O-Rings	10	50	
1-1/2"	12H-SKIT	all	Nitrile	<b>13.55</b>	Adapter/Valve O-Ring & Two Body O-Rings	10	50	
1-1/2"	F-12H-SKIT	all	FKM	<b>17.57</b>	Adapter/Valve O-Ring & Two Body O-Rings	10	50	
1-1/2"	P-12H-SKIT	all	EPDM	<b>16.85</b>	Adapter/Valve O-Ring & Two Body O-Rings	10	50	

## H-Series Hydraulic Couplings

Body Size	H-Series ISO-B Repair Kits						
	Part Detail			List Price	Repair Kit Contents (for one coupler or nipple)	Package Qty	
	Part Number	Coupler Style	Seal Material			Bag	Box
1/4"	2H-RKIT	steel	Nitrile	<b>\$5.91</b>	Steel Valve Assembly and Retaining Ring	1	25
1/4"	2H-BRKIT	brass	Nitrile	<b>7.00</b>	Brass Valve Assembly and Retaining Ring	1	25
1/4"	2H-SRKIT	303 stainless	Nitrile	<b>10.34</b>	303 SS Valve Assembly and Retaining Ring	1	25
1/4"	2H-SSRKIT	316 stainless	Nitrile	<b>14.85</b>	316 SS Valve Assembly and Retaining Ring	1	25
3/8"	3H-RKIT	steel	Nitrile	<b>7.85</b>	Steel Valve Assembly and Retaining Ring	1	25
3/8"	3H-BRKIT	brass	Nitrile	<b>9.14</b>	Brass Valve Assembly and Retaining Ring	1	25
3/8"	3H-SRKIT	303 stainless	Nitrile	<b>14.02</b>	303 SS Valve Assembly and Retaining Ring	1	25
3/8"	3H-SSRKIT	316 stainless	Nitrile	<b>18.50</b>	316 SS Valve Assembly and Retaining Ring	1	25
1/2"	4H-RKIT	steel	Nitrile	<b>10.73</b>	Steel Valve Assembly and Retaining Ring	1	25
1/2"	4H-BRKIT	brass	Nitrile	<b>15.67</b>	Brass Valve Assembly and Retaining Ring	1	25
1/2"	4H-SRKIT	303 stainless	Nitrile	<b>19.03</b>	303 SS Valve Assembly and Retaining Ring	1	25
1/2"	4H-SSRKIT	316 stainless	Nitrile	<b>32.10</b>	316 SS Valve Assembly and Retaining Ring	1	25
3/4"	6H-RKIT	steel	Nitrile	<b>12.13</b>	Steel Valve Assembly and Retaining Ring	1	25
3/4"	6H-BRKIT	brass	Nitrile	<b>17.32</b>	Brass Valve Assembly and Retaining Ring	1	25
3/4"	6H-SRKIT	303 stainless	Nitrile	<b>18.94</b>	303 SS Valve Assembly and Retaining Ring	1	25
3/4"	6H-SSRKIT	316 stainless	Nitrile	<b>81.12</b>	316 SS Valve Assembly and Retaining Ring	1	25
1"	8H-RKIT	steel	Nitrile	<b>17.05</b>	Steel Valve Assembly and Retaining Ring	1	25
1"	8H-BRKIT	brass	Nitrile	<b>30.58</b>	Brass Valve Assembly and Retaining Ring	1	25
1"	8H-SRKIT	303 stainless	Nitrile	<b>49.37</b>	303 SS Valve Assembly and Retaining Ring	1	25
1"	8H-SSRKIT	316 stainless	Nitrile	<b>87.60</b>	316 SS Valve Assembly and Retaining Ring	1	25
1-1/4"	10H-RKIT	steel	Nitrile	<b>20.89</b>	Steel Valve Assembly and Adapter O-Ring	1	25
1-1/4"	10H-BRKIT	brass	Nitrile	<b>37.12</b>	Brass Valve Assembly and Adapter O-Ring	1	25
1-1/4"	10H-SRKIT	303 stainless	Nitrile	<b>59.28</b>	303 SS Valve Assembly and Adapter O-Ring	1	25
1-1/4"	10H-SSRKIT	316 stainless	Nitrile	<b>109.49</b>	316 SS Valve Assembly and Adapter O-Ring	1	25
1-1/2"	12H-RKIT	steel	Nitrile	<b>26.59</b>	Steel Valve Assembly and Adapter O-Ring	1	25
1-1/2"	12H-BRKIT	brass	Nitrile	<b>45.88</b>	Brass Valve Assembly and Adapter O-Ring	1	25
1-1/2"	12H-SRKIT	303 stainless	Nitrile	<b>68.14</b>	303 SS Valve Assembly and Adapter O-Ring	1	25
1-1/2"	12H-SSRKIT	316 stainless	Nitrile	<b>131.40</b>	316 SS Valve Assembly and Adapter O-Ring	1	25



# HS-Series Hydraulic Couplings

## Interchange Data:

- Interchangeable to ISO7241 Series 'B'
- Parker 60-Series Steam Couplings

## Materials:

- Machined components are manufactured using solid steel, brass, or 303 stainless steel bar stock.
- Stainless steel balls, retaining rings, and springs maximize corrosion resistance and extend service life.
- Steel componentry is plated using ROHS Compliant Trivalent Chrome.
- Large diameter steel steam-sleeves are hardened to resist deformation and maximize coupler service life.
- Steel nipples are hardened to provide heavy duty performance and resist brinelling.
- All couplers have a steel steam-sleeve as standard.

## Seal Components:

- EPDM steam-grade seals are standard, providing a temperature range of -70°F to +400°F (-57°C to +204°C).
- Brass couplers have a redundant o-ring sealing system (Dual O-Rings/no PTFE Back-up Ring)
- Stainless couplers have an O-Ring/PTFE Anti-Extrusion ring sealing system.
- Valve seals are crimped in place to maintain integrity during excessive flow conditions.

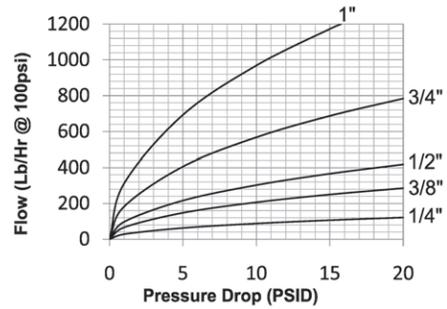

## Rated Pressure Chart:

Body Size	HS-Series ISO-B Steam Interchange (Connected)															
	Brass Coupler/Plug				Brass Coupler/Steel Plug				Brass Coupler/303 SS Plug				303SS Coupler/Plug			
	Max. Working		Burst		Max. Working		Burst		Max. Working		Burst		Max. Working		Burst	
	PSI	Bar	PSI	Bar	PSI	Bar	PSI	Bar	PSI	Bar	PSI	Bar	PSI	Bar	PSI	Bar
1/4"	200	14	14,500	1,000	200	14	14,500	1,000	200	14	14,500	1,000	200	14	31,500	2,150
3/8"	200	14	12,000	800	200	14	14,500	1,000	200	14	14,500	1,000	200	14	26,500	1,800
1/2"	200	14	11,500	750	200	14	14,500	1,000	200	14	14,500	1,000	200	14	27,500	1,900
3/4"	200	14	9,280	640	200	14	9,280	640	200	14	9,280	640	200	14	16,000	1,100
1"	200	14	5,800	400	200	14	5,800	400	200	14	5,800	400	200	14	15,000	1,000

## Technical Specifications:

Body Size	Interchange Standards				Functional Parameters					
	U.S. Military	U.S. Government	International Standards	ANSI/NFPA Standards	Locking Ball Quantity	Air Inclusion	Fluid Loss	Vacuum Inch HG	Flow ΔP = 10 PSI	
1/4"	-	-	ISO7241 'B'	B93.113M-B	8	1.1cc	0.9cc	27.4	88Lbs/Hr	
3/8"	-	-	ISO7241 'B'	B93.113M-B	9	2.6cc	1.8cc	27.4	206Lbs/Hr	
1/2"	-	-	ISO7241 'B'	B93.113M-B	9	3.8cc	2.9cc	27.4	302Lbs/Hr	
3/4"	-	-	ISO7241 'B'	B93.113M-B	12	10.8cc	9.7cc	27.4	567Lbs/Hr	
1"	-	-	ISO7241 'B'	B93.113M-B	12	15.9cc	15.3cc	27.4	968Lbs/Hr	

Note: Maximum working pressure has been calculated using saturated steam at 194°C (382°F) for general purpose continuous steam service. For advanced operating pressure or super-heated steam applications, contact the factory for further information.



## HS-Series Hydraulic Couplings

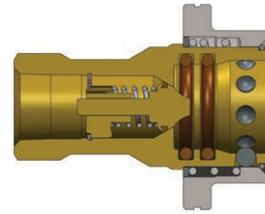

Body Size	H-Series ISO-B Steam Interchange Coupler (Female Threads)											
	Part Detail			List Price	Length		Maximum OD		Hex Inch	Weight Lb	Package Qty	
	Part Number	Threads	Material		Inch	mm	Inch	mm			Bag	Box
1/4"	2HSF2-B	1/4" - 18 NPTF	brass	<b>\$44.92</b>	2.26	57.4	1.42	36.1	3/4"	0.30	5	50
1/4"	2HSF2-S	1/4" - 18 NPTF	303 stainless	<b>91.85</b>	2.26	57.4	1.42	36.1	3/4"	0.30	5	50
1/4"	2HSBF2-B	1/4" - 19 BSPP	brass	<b>44.92</b>	2.26	57.4	1.42	36.1	3/4"	0.30	5	50
1/4"	2HSBF2-S	1/4" - 19 BSPP	303 stainless	<b>91.85</b>	2.26	57.4	1.42	36.1	3/4"	0.30	5	50
3/8"	3HSF3-B	3/8" - 18 NPTF	brass	<b>48.39</b>	2.51	63.8	1.73	43.9	7/8"	0.50	-	50
3/8"	3HSF3-S	3/8" - 18 NPTF	303 stainless	<b>113.39</b>	2.51	63.8	1.73	43.9	7/8"	0.50	-	50
3/8"	3HSBF3-B	3/8" - 19 BSPP	brass	<b>48.39</b>	2.51	63.8	1.73	43.9	7/8"	0.50	-	50
3/8"	3HSBF3-S	3/8" - 19 BSPP	303 stainless	<b>113.39</b>	2.51	63.8	1.73	43.9	7/8"	0.50	-	50
1/2"	4HSF4-B	1/2" - 14 NPTF	brass	<b>67.52</b>	2.86	72.6	2.29	58.2	1-1/16"	0.75	-	25
1/2"	4HSF4-S	1/2" - 14 NPTF	303 stainless	<b>171.42</b>	2.86	72.6	2.29	58.2	1-1/16"	0.75	-	25
1/2"	4HSBF4-B	1/2" - 14 BSPP	brass	<b>67.52</b>	2.86	72.6	2.29	58.2	1-1/16"	0.75	-	25
1/2"	4HSBF4-S	1/2" - 14 BSPP	303 stainless	<b>171.42</b>	2.86	72.6	2.29	58.2	1-1/16"	0.75	-	25
3/4"	6HSF6-B	3/4" - 14 NPTF	brass	<b>105.71</b>	3.55	90.2	2.61	66.3	1-5/16"	1.31	-	10
3/4"	6HSF6-S	3/4" - 14 NPTF	303 stainless	<b>271.58</b>	3.55	90.2	2.61	66.3	1-5/16"	1.31	-	10
3/4"	6HSBF6-B	3/4" - 14 BSPP	brass	<b>105.71</b>	3.55	90.2	2.61	66.3	1-5/16"	1.31	-	10
3/4"	6HSBF6-S	3/4" - 14 BSPP	303 stainless	<b>271.58</b>	3.55	90.2	2.61	66.3	1-5/16"	1.31	-	10
1"	8HSF8-B	1" - 11 1/2 NPTF	brass	<b>171.63</b>	4.13	104.9	2.98	75.7	1-5/8"	1.95	-	10
1"	8HSF8-S	1" - 11 1/2 NPTF	303 stainless	<b>464.48</b>	4.13	104.9	2.98	75.7	1-5/8"	1.95	-	10
1"	8HSBF8-B	1" - 11 BSPP	brass	<b>171.63</b>	4.13	104.9	2.98	75.7	1-5/8"	1.95	-	10
1"	8HSBF8-S	1" - 11 BSPP	303 stainless	<b>464.48</b>	4.13	104.9	2.98	75.7	1-5/8"	1.95	-	10



Do not disconnect steam couplings while under pressure! Maximum operating temperature for steam service couplings is 194°C (382°F), with an intermittent maximum temperature of 204°C (400°F). Be sure to use safety chains, or equivalent means, to prevent the line from thrashing around in a case where the coupling becomes disconnected.

## HS-Series Hydraulic Couplings

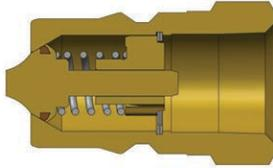

Body Size	H-Series ISO-B Steam Interchange Nipple (Female Threads)											
	Part Detail			List Price	Length		Maximum OD		Hex Inch	Weight Lb	Package Qty	
	Part Number	Threads	Material		Inch	mm	Inch	mm			Bag	Box
1/4"	HS2F2	1/4" - 18 NPTF	steel	<b>\$14.28</b>	1.55	39.4	0.83	21.1	3/4"	0.08	10	50
1/4"	HS2F2-B	1/4" - 18 NPTF	brass	<b>13.87</b>	1.55	39.4	0.83	21.1	3/4"	0.08	10	50
1/4"	HS2F2-S	1/4" - 18 NPTF	303 stainless	<b>30.91</b>	1.55	39.4	0.83	21.1	3/4"	0.08	10	50
1/4"	HS2BF2	1/4" - 19 BSPP	steel	<b>14.28</b>	1.55	39.4	0.83	21.1	3/4"	0.08	10	50
1/4"	HS2BF2-B	1/4" - 19 BSPP	brass	<b>13.87</b>	1.55	39.4	0.83	21.1	3/4"	0.08	10	50
1/4"	HS2BF2-S	1/4" - 19 BSPP	303 stainless	<b>30.91</b>	1.55	39.4	0.83	21.1	3/4"	0.08	10	50
3/8"	HS3F3	3/8" - 18 NPTF	steel	<b>19.17</b>	1.70	43.2	0.97	24.6	7/8"	0.13	10	50
3/8"	HS3F3-B	3/8" - 18 NPTF	brass	<b>19.63</b>	1.70	43.2	0.97	24.6	7/8"	0.13	10	50
3/8"	HS3F3-S	3/8" - 18 NPTF	303 stainless	<b>49.70</b>	1.70	43.2	0.97	24.6	7/8"	0.13	10	50
3/8"	HS3BF3	3/8" - 19 BSPP	steel	<b>19.17</b>	1.70	43.2	0.97	24.6	7/8"	0.13	10	50
3/8"	HS3BF3-B	3/8" - 19 BSPP	brass	<b>19.63</b>	1.70	43.2	0.97	24.6	7/8"	0.13	10	50
3/8"	HS3BF3-S	3/8" - 19 BSPP	303 stainless	<b>49.70</b>	1.70	43.2	0.97	24.6	7/8"	0.13	10	50
1/2"	HS4F4	1/2" - 14 NPTF	steel	<b>26.67</b>	1.94	49.3	1.17	29.7	1-1/16"	0.24	5	25
1/2"	HS4F4-B	1/2" - 14 NPTF	brass	<b>24.67</b>	1.94	49.3	1.17	29.7	1-1/16"	0.24	5	25
1/2"	HS4F4-S	1/2" - 14 NPTF	303 stainless	<b>78.44</b>	1.94	49.3	1.17	29.7	1-1/16"	0.24	5	25
1/2"	HS4BF4	1/2" - 14 BSPP	steel	<b>26.67</b>	1.94	49.3	1.17	29.7	1-1/16"	0.24	5	25
1/2"	HS4BF4-B	1/2" - 14 BSPP	brass	<b>24.67</b>	1.94	49.3	1.17	29.7	1-1/16"	0.24	5	25
1/2"	HS4BF4-S	1/2" - 14 BSPP	303 stainless	<b>78.44</b>	1.94	49.3	1.17	29.7	1-1/16"	0.24	5	25
3/4"	HS6F6	3/4" - 14 NPTF	steel	<b>41.86</b>	2.41	61.2	1.44	36.6	1-5/16"	0.46	-	10
3/4"	HS6F6-B	3/4" - 14 NPTF	brass	<b>43.32</b>	2.41	61.2	1.44	36.6	1-5/16"	0.46	-	10
3/4"	HS6F6-S	3/4" - 14 NPTF	303 stainless	<b>123.83</b>	2.41	61.2	1.44	36.6	1-5/16"	0.46	-	10
3/4"	HS6BF6	3/4" - 14 BSPP	steel	<b>41.86</b>	2.41	61.2	1.44	36.6	1-5/16"	0.46	-	10
3/4"	HS6BF6-B	3/4" - 14 BSPP	brass	<b>43.32</b>	2.41	61.2	1.44	36.6	1-5/16"	0.46	-	10
3/4"	HS6BF6-S	3/4" - 14 BSPP	303 stainless	<b>123.83</b>	2.41	61.2	1.44	36.6	1-5/16"	0.46	-	10
1"	HS8F8	1" - 11 1/2 NPTF	steel	<b>55.22</b>	2.87	72.9	1.79	45.5	1-5/8"	0.76	-	10
1"	HS8F8-B	1" - 11 1/2 NPTF	brass	<b>56.64</b>	2.87	72.9	1.79	45.5	1-5/8"	0.76	-	10
1"	HS8F8-S	1" - 11 1/2 NPTF	303 stainless	<b>196.12</b>	2.87	72.9	1.79	45.5	1-5/8"	0.76	-	10
1"	HS8BF8	1" - 11 BSPP	steel	<b>55.22</b>	2.87	72.9	1.79	45.5	1-5/8"	0.76	-	10
1"	HS8BF8-B	1" - 11 BSPP	brass	<b>56.64</b>	2.87	72.9	1.79	45.5	1-5/8"	0.76	-	10
1"	HS8BF8-S	1" - 11 BSPP	303 stainless	<b>196.12</b>	2.87	72.9	1.79	45.5	1-5/8"	0.76	-	10

# K-Series Hydraulic Couplings

## Interchange Data:

- Interchangeable to ISO7241 Series 'A'
- Parker 6600-Series, Aeroquip/Eaton FD56 (5600)
- Faster ANV, Hansen HA15000, Safeway S56-Series

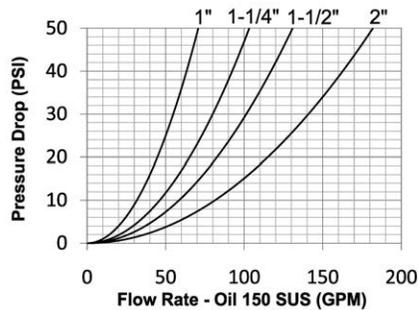
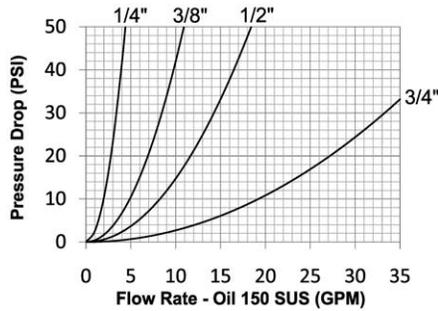

## Materials:

- Machined components are manufactured using solid steel bar stock.
- Stainless steel balls, retaining rings, and springs maximize corrosion resistance and extend service life.
- Steel componentry is plated using ROHS Compliant Trivalent Chrome.
- Steel coupler sleeves are hardened to resist deformation and maximize service life.
- Steel nipples are hardened to provide heavy duty performance and resist brinelling.

## Seal Components:

- Nitrile (Buna-N) seals are standard, providing a temperature range of -40°F to +250°F (-40°C to +121°C).
- Couplers have a PTFE Anti-Extrusion ring.
- Valve seals are crimped in place to maintain integrity during excessive flow conditions and pressurized connection.

## Rated Pressure Chart:

Body Size	K-Series ISO-A Interchange (Connected)			
	Steel Coupler/Plug			
	Maximum Working		Burst	
	PSI	Bar	PSI	Bar
1/4"	5,000	345	18,270	1,200
3/8"	4,000	275	18,270	1,200
1/2"	4,000	275	16,500	1,100
3/4"	4,000	275	14,800	1,000
1"	4,000	275	12,400	850
1-1/4"	3,000	200	12,600	850
1-1/2"	3,000	200	12,600	850
2"	1,450	100	5,800	400

## Technical Specifications:

Body Size	Interchange Standards				Functional Parameters				
	U.S. Military	U.S. Government	International Standards	ANSI/NFPA Standards	Locking Ball Quantity	Air Inclusion	Fluid Loss	Vacuum Inch HG	Flow $\Delta P = 22$ PSI
1/4"	-	-	ISO7241 'A'	B93.113M-A	6	0.6cc	0.3cc	26.5	2.9 GPM
3/8"	-	-	ISO7241 'A'	B93.113M-A	9	2.6cc	1.8cc	26.5	7 GPM
1/2"	-	-	ISO7241 'A'	B93.113M-A	9	3.8cc	2.9cc	26.5	12 GPM
3/4"	-	-	ISO7241 'A'	B93.113M-A	12	10.8cc	9.7cc	26.5	28 GPM
1"	-	-	ISO7241 'A'	B93.113M-A	15	15.9cc	15.3cc	26.5	50 GPM
1-1/4"	-	-	ISO7241 'A'	B93.113M-A	16	31.7cc	29.1cc	26.5	70 GPM
1-1/2"	-	-	ISO7241 'A'	B93.113M-A	16	56.4cc	52.2cc	26.5	90 GPM
2"	-	-	ISO7241 'A'	B93.113M-A	15	N/A	N/A	26.5	120 GPM

## K-Series Hydraulic Couplings

### List Price Seal Option Adders:

Body Size	Standard Seal Options										Kalrez® Seal Options							
	FKM		EPDM		FDA FKM		Mil-Nitrile		Fuel Nitrile		Silicone		4079		6375		7075	
	Pre	Add \$	Pre	Add \$	Pre	Add \$	Pre	Add \$	Pre	Add \$	Pre	Add \$	Pre	Add \$	Pre	Add \$	Pre	Add \$
1/4"	F-	\$0.00	P-	\$2.60	D-	\$3.00	M-	\$2.50	JF-	\$2.90	S-	\$3.10	K4-	POR	K6-	POR	K7-	POR
3/8"	F-	.00	P-	3.00	D-	3.50	M-	2.90	JF-	3.70	S-	3.80	K4-	POR	K6-	POR	K7-	POR
1/2"	F-	.00	P-	3.50	D-	4.00	M-	3.60	JF-	3.80	S-	4.30	K4-	POR	K6-	POR	K7-	POR
3/4"	F-	.00	P-	4.00	D-	6.20	M-	5.20	JF-	5.80	S-	6.00	K4-	POR	K6-	POR	K7-	POR
1"	F-	.00	P-	6.20	D-	7.60	M-	6.80	JF-	6.90	S-	7.60	K4-	POR	K6-	POR	K7-	POR
1-1/4"	F-	N/A	P-	N/A	D-	N/A	M-	N/A	JF-	N/A	S-	N/A	K4-	N/A	K6-	N/A	K7-	N/A
1-1/2"	F-	N/A	P-	N/A	D-	N/A	M-	N/A	JF-	N/A	S-	N/A	K4-	N/A	K6-	N/A	K7-	N/A
2"	F-	N/A	P-	N/A	D-	N/A	M-	N/A	JF-	N/A	S-	N/A	K4-	N/A	K6-	N/A	K7-	N/A

### List Price Option Adders:

Body Size	Valve Options										Sleeve		Treatments			
	Unvalved		Actuator*		Steel		Brass		303 SS		316 SS		Locking		Oxy-Clean	
	Suf	Add \$	Suf	Add \$	Suf	Add \$	Suf	Add \$	Suf	Add \$	Suf	Add \$	Suf	Add \$	Suf	Add \$
1/4"	-E	-\$1.50	-VA	N/A	-ZV	Std.	-BV	POR	-SV	N/A	SSV	N/A	-LS	\$4.80	-C1	\$12.00
3/8"	-E	-2.30	-VA	\$4.30	-ZV	Std.	-BV	POR	-SV	\$2.45	SSV	\$2.70	-LS	4.80	-C1	12.00
1/2"	-E	-4.60	-VA	6.20	-ZV	Std.	-BV	POR	-SV	4.30	SSV	4.80	-LS	4.80	-C1	14.00
3/4"	-E	-5.80	-VA	8.00	-ZV	Std.	-BV	POR	-SV	5.65	SSV	6.00	-LS	6.00	-C1	14.00
1"	-E	-8.50	-VA	12.00	-ZV	Std.	-BV	POR	-SV	7.50	SSV	8.80	-LS	9.80	-C1	16.00
1-1/4"	-E	N/A	-VA	N/A	-ZV	Std.	-BV	N/A	-SV	N/A	SSV	N/A	-LS	N/A	-C1	N/A
1-1/2"	-E	N/A	-VA	N/A	-ZV	Std.	-BV	N/A	-SV	N/A	SSV	N/A	-LS	N/A	-C1	N/A
2"	-E	N/A	-VA	N/A	-ZV	Std.	-BV	N/A	-SV	N/A	SSV	N/A	-LS	N/A	-C1	N/A

\* Brass Valve Actuator

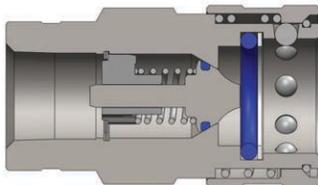

Body Size	K-Series ISO-A Interchange Coupler (Female Threads)											
	Part Detail			List Price	Length		Maximum OD		Hex Inch	Weight Lb	Package Qty	
	Part Number	Threads	Material		Inch	mm	Inch	mm			Bag	Box
1/4"	2KF1	1/8" - 27 NPTF	steel	\$26.06	1.76	44.7	1	25.4	3/4"	0.27	10	50
1/4"	2KF2	1/4" - 18 NPTF	steel	21.14	1.76	44.7	1	25.4	3/4"	0.26	10	50
1/4"	2KBF2	1/4" - 19 BSPP	steel	26.06	1.76	44.7	1	25.4	3/4"	0.26	10	50
1/4"	2KOF2	7/16" - 20 ORB	steel	26.06	1.76	44.7	1	25.4	3/4"	0.25	10	50
3/8"	3KF3	3/8" - 18 NPTF	steel	28.38	2.23	56.6	1.23	31.2	1"	0.39	10	50
3/8"	3KBF3	3/8" - 19 BSPP	steel	33.01	2.23	56.6	1.23	31.2	1"	0.38	10	50
3/8"	3KOF3	9/16" - 18 ORB	steel	33.01	2.23	56.6	1.23	31.2	1"	0.39	10	50
1/2"	4KF4	1/2" - 14 NPTF	steel	28.38	2.62	66.5	1.49	37.8	1-1/4"	0.67	5	25
1/2"	4KBF4	1/2" - 14 BSPP	steel	33.01	2.62	66.5	1.49	37.8	1-1/4"	0.67	5	25
1/2"	4KOF4	3/4" - 16 ORB	steel	33.01	2.62	66.5	1.49	37.8	1-1/4"	0.69	5	25
1/2"	4KOF5	7/8" - 14 ORB	steel	34.75	2.62	66.5	1.49	37.8	1-1/4"	0.66	5	25
1/2"	4KF6	3/4" - 14 NPTF	steel	46.91	2.62	66.5	1.49	37.8	1-1/4"	0.71	5	25
1/2"	4KBF6	3/4" - 14 BSPP	steel	50.05	2.62	66.5	1.49	37.8	1-1/4"	0.71	5	25

## K-Series Hydraulic Couplings

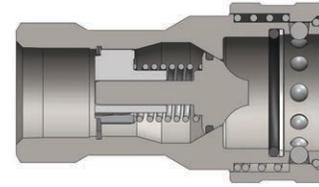

Body Size	K-Series ISO-A Interchange Coupler (Female Threads)											
	Part Detail			List Price	Length		Maximum OD		Hex Inch	Weight Lb	Package Qty	
	Part Number	Threads	Material		Inch	mm	Inch	mm			Bag	Box
3/4"	6KF6	3/4" - 14 NPTF	steel	\$55.60	3.23	82.0	1.86	47.2	1-5/16"	1.90	-	10
3/4"	6KBF6	3/4" - 14 BSPP	steel	69.49	3.23	82.0	1.86	47.2	1-5/16"	1.90	-	10
3/4"	6KOF6	1-1/16" - 12 ORB	steel	69.49	3.23	82.0	1.86	47.2	1-5/16"	1.90	-	10
1"	8KF8	1" - 11 1/2 NPTF	steel	81.08	3.88	98.6	2.10	53.3	1-5/8"	2.14	-	10
1"	8KBF8	1" - 11 BSPP	steel	101.93	3.88	98.6	2.10	53.3	1-5/8"	2.14	-	10
1"	8KOF8	1-5/16" - 12 ORB	steel	101.93	3.88	98.6	2.10	53.3	1-5/8"	2.14	-	10

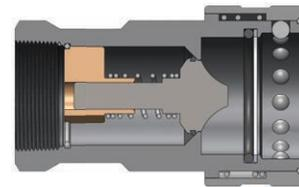

Body Size	K-Series ISO-A Interchange Coupler (Female Threads)											
	Part Detail			List Price	Length		Maximum OD		Hex Inch	Weight Lb	Package Qty	
	Part Number	Threads	Material		Inch	mm	Inch	mm			Bag	Box
1-1/4"	10KF10	1-1/4" - 11 1/2 NPT	steel	\$214.57	4.61	117.0	2.76	70.0	2"	2.93	-	10
1-1/4"	10KBF10	1-1/4" - 11 BSPP	steel	238.40	4.61	117.0	2.76	70.0	2"	2.93	-	10
1-1/2"	12KF12	1-1/2" - 11 1/2 NPT	steel	357.61	5.24	133.0	3.33	84.5	2-3/8"	4.78	-	1
1-1/2"	12KBF12	1-1/2" - 11 BSPP	steel	393.37	5.24	133.0	3.33	84.5	2-3/8"	4.78	-	1
2"	16KF16	2" - 11 1/2 NPT	steel	709.26	6.50	165.0	3.94	100.0	3"	8.49	-	1
2"	16KBF16	2" - 11 BSPP	steel	750.97	6.50	165.0	3.94	100.0	3"	8.49	-	1

### K Profiles

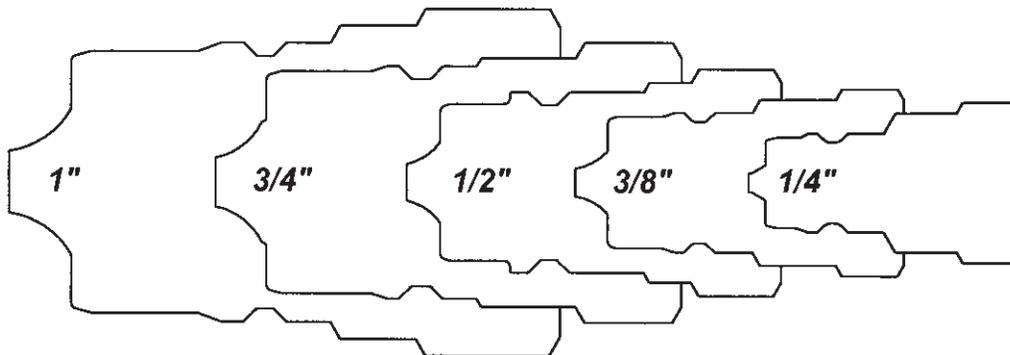

## K-Series Hydraulic Couplings

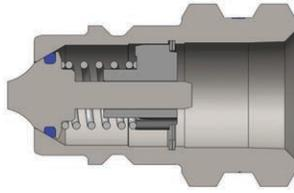

Body Size	K-Series ISO-A Interchange Nipple (Female Threads)											
	Part Detail			List Price	Length		Maximum OD		Hex Inch	Weight Lb	Package Qty	
	Part Number	Threads	Material		Inch	mm	Inch	mm			Bag	Box
1/4"	K2F1	1/8" - 27 NPTF	steel	<b>\$14.13</b>	1.22	31.0	0.87	22.1	3/4"	0.08	10	50
1/4"	K2F2	1/4" - 18 NPTF	steel	<b>9.56</b>	1.22	31.0	0.87	22.1	3/4"	0.07	10	50
1/4"	K2BF2	1/4" - 19 BSPP	steel	<b>14.13</b>	1.22	31.0	0.87	22.1	3/4"	0.07	10	50
1/4"	K2OF2	7/16" - 20 ORB	steel	<b>14.13</b>	1.22	31.0	0.87	22.1	3/4"	0.08	10	50
3/8"	K3F3	3/8" - 18 NPTF	steel	<b>12.45</b>	1.70	43.2	0.97	24.6	7/8"	0.11	10	50
3/8"	K3BF3	3/8" - 19 BSPP	steel	<b>18.53</b>	1.70	43.2	0.97	24.6	7/8"	0.11	10	50
3/8"	K3OF3	9/16" - 18 ORB	steel	<b>18.53</b>	1.70	43.2	0.97	24.6	7/8"	0.13	10	50
1/2"	K4F4	1/2" - 14 NPTF	steel	<b>13.32</b>	1.77	45.0	1.23	31.2	1-1/16"	0.21	5	25
1/2"	K4BF4	1/2" - 14 BSPP	steel	<b>19.12</b>	1.77	45.0	1.23	31.2	1-1/16"	0.21	5	25
1/2"	K4OF4	3/4" - 16 ORB	steel	<b>19.12</b>	1.77	45.0	1.23	31.2	1-1/16"	0.22	5	25
1/2"	K4OF5	7/8" - 14 ORB	steel	<b>20.85</b>	1.77	45.0	1.23	31.2	1-1/16"	0.21	5	25
1/2"	K4F6	3/4" - 14 NPTF	steel	<b>25.48</b>	1.77	45.0	1.37	34.8	1-3/16"	0.33	5	25
1/2"	K4BF6	3/4" - 14 BSPP	steel	<b>27.80</b>	1.77	45.0	1.37	34.8	1-3/16"	0.33	5	25

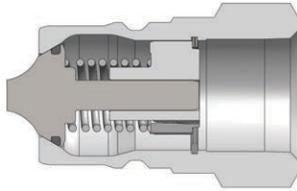

Body Size	K-Series ISO-A Interchange Nipple (Female Threads)											
	Part Detail			List Price	Length		Maximum OD		Hex Inch	Weight Lb	Package Qty	
	Part Number	Threads	Material		Inch	mm	Inch	mm			Bag	Box
3/4"	K6F6	3/4" - 14 NPTF	steel	<b>\$28.38</b>	2.43	61.7	1.44	36.6	1-5/16"	0.49	-	10
3/4"	K6BF6	3/4" - 14 BSPP	steel	<b>36.48</b>	2.43	61.7	1.44	36.6	1-5/16"	0.49	-	10
3/4"	K6OF6	1-1/16" - 12 ORB	steel	<b>36.48</b>	2.43	61.7	1.44	36.6	1-5/16"	0.47	-	10
1"	K8F8	1" - 11 1/2 NPTF	steel	<b>44.01</b>	2.87	72.9	1.79	45.5	1-5/8"	0.75	-	10
1"	K8BF8	1" - 11 BSPP	steel	<b>50.96</b>	2.87	72.9	1.79	45.5	1-5/8"	0.75	-	10
1"	K8OF8	1-5/16" - 12 ORB	steel	<b>50.96</b>	2.87	72.9	1.79	45.5	1-5/8"	0.72	-	10
1-1/4"	K10F10	1-1/4" - 11 1/2 NPT	steel	<b>122.78</b>	2.95	75.0	2.31	58.7	2"	1.26	-	10
1-1/4"	K10BF10	1-1/4" - 11 BSPP	steel	<b>143.05</b>	2.95	75.0	2.31	58.7	2"	1.26	-	10
1-1/2"	K12F12	1-1/2" - 11 1/2 NPT	steel	<b>184.76</b>	3.29	83.5	2.74	69.6	2-3/8"	2.05	-	1
1-1/2"	K12BF12	1-1/2" - 11 BSPP	steel	<b>220.52</b>	3.29	83.5	2.74	69.6	2-3/8"	2.05	-	1
2"	K16F16	2" - 11 1/2 NPT	steel	<b>345.69</b>	4.13	105.0	3.46	87.9	3"	3.64	-	1
2"	K16BF16	2" - 11 BSPP	steel	<b>387.41</b>	4.13	105.0	3.46	87.9	3"	3.64	-	1

## K-Series Hydraulic Couplings



Body Size	K-Series ISO-A Interchange Combination Dust Cap and Plug					
	Part Detail			List Price	Package Qty	
	Combination Dust Plug & Cap	Material	Bag		Box	
1/4"	2KDP-K2DC	Nitrile	<b>\$3.16</b>	10	50	
3/8"	3KDP-K3DC	Nitrile	<b>3.51</b>	10	50	
1/2"	See Below					
3/4"	6KDP-K6DC	Nitrile	<b>5.29</b>	5	25	
1"	8KDP-K8DC	Nitrile	<b>6.68</b>	5	25	



Body Size	K-Series ISO-A Interchange Color Coded Dust Plug					
	Part Detail			List Price	Package Qty	
	Part Number	Color	Material		Bag	Box
1/2"	4KDP	Black	Nitrile	<b>\$3.16</b>	10	50
1/2"	4K-R-DP	Red	Nitrile	<b>3.16</b>	10	50
1/2"	4K-O-DP	Orange	Nitrile	<b>3.16</b>	10	50
1/2"	4K-Y-DP	Yellow	Nitrile	<b>3.16</b>	10	50
1/2"	4K-G-DP	Green	Nitrile	<b>3.16</b>	10	50
1/2"	4K-B-DP	Blue	Nitrile	<b>3.16</b>	10	50



Body Size	K-Series ISO-A Interchange Color Coded Dust Cap					
	Part Detail			List Price	Package Qty	
	Part Number	Color	Material		Bag	Box
1/2"	K4DC	Black	Nitrile	<b>\$3.16</b>	10	50
1/2"	K4-R-DC	Red	Nitrile	<b>3.16</b>	10	50
1/2"	K4-O-DC	Orange	Nitrile	<b>3.16</b>	10	50
1/2"	K4-Y-DC	Yellow	Nitrile	<b>3.16</b>	10	50
1/2"	K4-G-DC	Green	Nitrile	<b>3.16</b>	10	50
1/2"	K4-B-DC	Blue	Nitrile	<b>3.16</b>	10	50

Body Size	K-Series ISO-A Coupler Seal Kits						
	Part Detail			List Price	Seal Kit Contents	Package Qty	
	Part Number	Coupler Style	Seal Material			Bag	Box
1/4"	2K-SKIT	all	Nitrile	<b>\$2.21</b>	O-Ring and PTFE Anti-Extrusion Ring	25	200
3/8"	3K-SKIT	all	Nitrile	<b>4.60</b>	O-Ring and PTFE Anti-Extrusion Ring	25	200
1/2"	4K-SKIT	all	Nitrile	<b>5.42</b>	O-Ring and PTFE Anti-Extrusion Ring	25	200
3/4"	6K-SKIT	all	Nitrile	<b>7.42</b>	O-Ring and PTFE Anti-Extrusion Ring	25	200
1"	8K-SKIT	all	Nitrile	<b>9.42</b>	O-Ring and PTFE Anti-Extrusion Ring	25	200
1-1/4"	10K-SKIT	all	Nitrile	<b>13.69</b>	O-Ring and PTFE Anti-Extrusion Ring	10	50
1-1/2"	12K-SKIT	all	Nitrile	<b>14.92</b>	O-Ring and PTFE Anti-Extrusion Ring	10	50
2"	16K-SKIT	all	Nitrile	<b>16.37</b>	O-Ring and PTFE Anti-Extrusion Ring	10	50



# AG-Series Hydraulic Couplings

## Interchange Data:

- Pioneer Agricultural Interchange
- Parker/Pioneer 4000 Series, Faster NS/NV-Series
- Safeway Series-S20, Stucchi IR-Series, Snap-Tite 60-Series

## Materials:

- Machined components are manufactured using solid steel bar stock.
- Stainless steel balls, retaining rings, and springs maximize corrosion resistance and extend service life.
- Steel componentry is plated using ROHS Compliant Trivalent Chrome.
- Steel coupler sleeves are hardened to resist deformation and maximize service life.
- Steel nipples are hardened to provide heavy duty performance and resist brinelling.

## Seal Components:

- Nitrile (Buna-N) seals are standard, providing a temperature range of -40°F to +250°F (-40°C to +121°C).
- Couplers have a PTFE Anti-Extrusion ring.
- Poppet valve seals are crimped in place to maintain integrity during excessive flow conditions and pressurized connection.
- Piloted ball valve has a seal that is crimped to prevent low-pressure leakage.

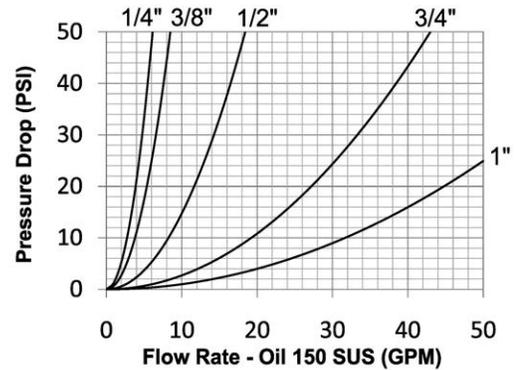

## Rated Pressure Chart:

Body Size	AG-Series Agricultural Interchange (Connected)							
	Ball Steel Coupler/Plug				Poppet Steel Coupler/Plug			
	Maximum Working		Burst		Maximum Working		Burst	
	PSI	Bar	PSI	Bar	PSI	Bar	PSI	Bar
1/4"	4,000	275	24,400	1,700	4,000	275	21,000	1,500
3/8"	4,000	275	25,000	1,700	4,000	275	23,100	1,600
1/2"	4,000	275	16,500	1,100	4,000	275	16,500	1,100
3/4"	3,000	200	15,800	1,050	3,000	200	10,300	700
1"	3,000	200	13,500	900	3,000	200	13,000	900

## Technical Specifications:

Body Size	Interchange Standards				Functional Parameters				
	U.S. Military	U.S. Government	International Standards	ANSI/NFPA Standards	Locking Ball Quantity	Air Inclusion	Fluid Loss	Vacuum Inch HG	Flow $\Delta P = 22$ PSI
1/4"	-	-	-	-	8	1.1cc	0.9cc	26.5	4 GPM
3/8"	-	-	-	-	9	2.6cc	1.8cc	26.5	6 GPM
1/2"	-	-	ISO7241 'A'	-	9	3.8cc	2.9cc	26.5	12 GPM
3/4"	-	-	ISO5675	-	12	10.8cc	9.7cc	26.5	28 GPM
1"	-	-	-	-	12	15.9cc	15.3cc	26.5	48 GPM

## AG Series Profiles

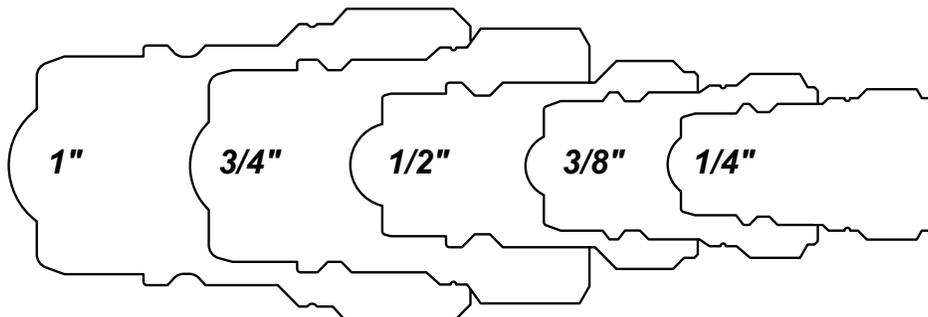

## AG-Series Hydraulic Couplings

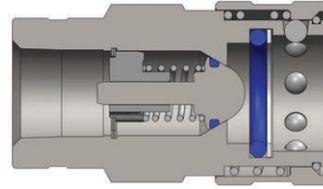
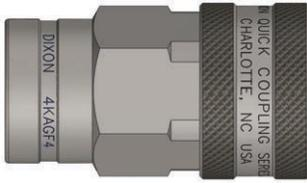

Body Size	AG-Series Agricultural Interchange Ball Valve Coupler (Female Threads)											
	Part Detail			List Price	Length		Maximum OD		Hex Inch	Weight Lb	Package Qty	
	Part Number	Threads	Material		Inch	mm	Inch	mm			Bag	Box
1/4"	2AGF2	1/4" - 18 NPTF	steel	<b>\$24.43</b>	2.11	53.5	1.06	27.0	7/8"	0.24	10	50
3/8"	3AGF3	3/8" - 18 NPTF	steel	<b>25.63</b>	2.40	61.0	1.34	34.0	1-1/16"	0.51	10	50
1/2"	4AGF4	1/2" - 14 NPTF	steel	<b>29.20</b>	2.62	66.5	1.49	37.8	1-1/4"	0.58	5	25
1/2"	4AGBF4	1/2" - 14 BSPP	steel	<b>33.97</b>	2.62	66.5	1.49	37.8	1-1/4"	0.58	5	25
1/2"	4AGOF4	3/4" - 16 ORB	steel	<b>33.97</b>	2.62	66.5	1.49	37.8	1-1/4"	0.64	5	25
1/2"	4AGOF5	7/8" - 14 ORB	steel	<b>35.76</b>	2.62	66.5	1.49	37.8	1-1/4"	0.59	5	25
1/2"	4AGF6	3/4" - 14 NPTF	steel	<b>48.28</b>	2.62	66.5	1.49	37.8	1-1/4"	0.71	5	25
3/4"	6AGF6	3/4" - 14 NPTF	steel	<b>65.56</b>	3.35	85.0	1.89	48.0	1-1/2"	1.00	-	10
1"	8AGF8	1" - 11 1/2 NPTF	steel	<b>88.21</b>	3.80	96.5	2.17	55.0	1-13/16"	1.89	-	10

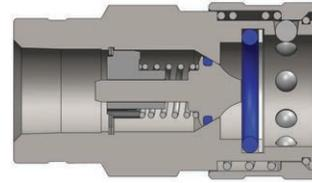

Body Size	AG-Series Agricultural Interchange Poppet Valve Coupler (Female Threads)											
	Part Detail			List Price	Length		Maximum OD		Hex Inch	Weight Lb	Package Qty	
	Part Number	Threads	Material		Inch	mm	Inch	mm			Bag	Box
1/4"	2AGF2-PV	1/4" - 18 NPTF	steel	<b>\$24.43</b>	2.11	53.5	1.06	27.0	7/8"	0.24	10	50
3/8"	3AGF3-PV	3/8" - 18 NPTF	steel	<b>25.63</b>	2.40	61.0	1.34	34.0	1-1/16"	0.51	10	50
1/2"	4AGF4-PV	1/2" - 14 NPTF	steel	<b>27.55</b>	2.62	66.5	1.49	37.8	1-1/4"	0.58	5	25
1/2"	4AGBF4-PV	1/2" - 14 BSPP	steel	<b>32.05</b>	2.62	66.5	1.49	37.8	1-1/4"	0.58	5	25
1/2"	4AGOF4-PV	3/4" - 16 ORB	steel	<b>32.05</b>	2.62	66.5	1.49	37.8	1-1/4"	0.64	5	25
1/2"	4AGOF5-PV	7/8" - 14 ORB	steel	<b>33.73</b>	2.62	66.5	1.49	37.8	1-1/4"	0.59	5	25
1/2"	4AGF6-PV	3/4" - 14 NPTF	steel	<b>45.55</b>	2.62	66.5	1.49	37.8	1-1/4"	0.71	5	25
3/4"	6AGF6-PV	3/4" - 14 NPTF	steel	<b>65.56</b>	3.35	85.0	1.89	48.0	1-1/2"	1.00	-	10
1"	8AGF8-PV	1" - 11 1/2 NPTF	steel	<b>88.21</b>	3.80	96.5	2.17	55.0	1-13/16"	1.89	-	10

## AG-Series Hydraulic Couplings

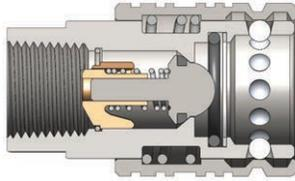

Body Size	AG-Series Agricultural Push-Pull Ball Valve Coupler (Female Threads)											
	Part Detail			List Price	Length		Maximum OD		Hex Inch	Weight Lb	Package Qty	
	Part Number	Threads	Material		Inch	mm	Inch	mm			Bag	Box
1/2"	4AGF4-PS	1/2" - 14 NPTF	steel	<b>\$41.73</b>	2.50	63.5	1.49	37.8	1-1/16"	0.75	5	25
1/2"	4AGOF4-PS	3/4" - 16 ORB	steel	<b>43.15</b>	2.98	75.8	1.489	37.8	1-1/16"	0.83	5	25
1/2"	4AGOF5-PS	7/8" - 14 ORB	steel	<b>44.64</b>	2.98	75.8	1.489	37.8	1-1/16"	0.75	5	25
1/2"	4AGF6-PS	3/4" - 14 NPTF	steel	<b>44.65</b>	3.06	77.8	1.489	37.8	1-3/16"	0.75	5	25

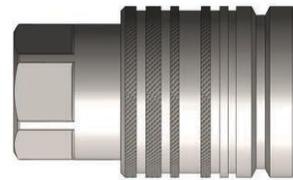
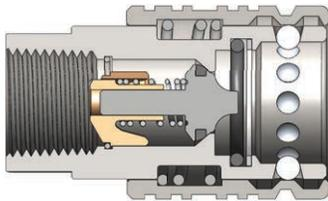

Body Size	AG-Series Agricultural Push-Pull Poppet Valve Coupler (Female Threads)											
	Part Detail			List Price	Length		Maximum OD		Hex Inch	Weight Lb	Package Qty	
	Part Number	Threads	Material		Inch	mm	Inch	mm			Bag	Box
1/2"	4AGF4-PV-PS	1/2" - 14 NPTF	steel	<b>\$41.73</b>	2.50	63.5	1.49	37.8	1-1/16"	0.75	5	25
1/2"	4AGOF4-PV-PS	3/4" - 16 ORB	steel	<b>43.15</b>	2.98	75.8	1.49	37.8	1-1/16"	0.83	5	25
1/2"	4AGOF5-PV-PS	7/8" - 14 ORB	steel	<b>44.65</b>	2.98	75.8	1.49	37.8	1-1/16"	0.75	5	25
1/2"	4AGF6-PV-PS	3/4" - 14 NPTF	steel	<b>42.91</b>	3.06	77.8	1.49	37.8	1-3/16"	0.75	5	25

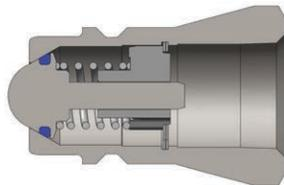

Body Size	AG-Series Agricultural Interchange Ball Valve Nipple (Female Threads)											
	Part Detail			List Price	Length		Maximum OD		Hex Inch	Weight Lb	Package Qty	
	Part Number	Threads	Material		Inch	mm	Inch	mm			Bag	Box
1/4"	AG2F2	1/4" - 18 NPTF	steel	<b>\$9.84</b>	1.42	36.0	0.86	21.8	3/4"	0.08	10	50
3/8"	AG3F3	3/8" - 18 NPTF	steel	<b>11.92</b>	1.59	40.5	1.08	27.4	15/16"	0.16	10	50
1/2"	AG4F4	1/2" - 14 NPTF	steel	<b>12.51</b>	1.77	45.0	1.23	31.2	1-1/16"	0.20	5	25
1/2"	AG4BF4	1/2" - 14 BSPP	steel	<b>16.69</b>	1.77	45.0	1.23	31.2	1-1/16"	0.20	5	25
1/2"	AG4OF4	3/4" - 16 ORB	steel	<b>16.69</b>	1.77	45.0	1.23	31.2	1-1/16"	0.25	5	25
1/2"	AG4OF5	7/8" - 14 ORB	steel	<b>17.88</b>	1.77	45.0	1.23	31.2	1-1/16"	0.25	5	25
1/2"	AG4F6	3/4" - 14 NPTF	steel	<b>19.08</b>	1.77	45.0	1.37	34.8	1-3/16"	0.25	5	25
3/4"	AG6F6	3/4" - 14 NPTF	steel	<b>32.19</b>	2.20	56.0	1.58	40.1	1-3/8"	0.50	-	10
1"	AG8F8	1" - 11 1/2 NPTF	steel	<b>47.68</b>	2.48	63.0	1.87	47.5	1-5/8"	0.62	-	10

## AG-Series Hydraulic Couplings

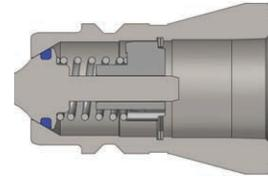

Body Size	AG-Series Agricultural Interchange Poppet Valve Nipple (Female Threads)											
	Part Detail			List Price	Length		Maximum OD		Hex Inch	Weight Lb	Package Qty	
	Part Number	Threads	Material		Inch	mm	Inch	mm			Bag	Box
1/4"	AG2F2-PV	1/4" - 18 NPTF	steel	\$9.84	1.42	36.0	0.86	21.8	3/4"	0.08	10	50
3/8"	AG3F3-PV	3/8" - 18 NPTF	steel	11.92	1.59	40.5	1.08	27.4	15/16"	0.16	10	50
1/2"	AG4F4-PV	1/2" - 14 NPTF	steel	12.51	1.77	45.0	1.23	31.2	1-1/16"	0.20	5	25
1/2"	AG4BF4-PV	1/2"-14 BSPP	steel	16.69	1.77	45.0	1.23	31.2	1-1/16"	0.20	5	25
1/2"	AG4OF4-PV	3/4" - 16 ORB	steel	16.69	1.77	45.0	1.23	31.2	1-1/16"	0.25	5	25
1/2"	AG4OF5-PV	7/8" - 14 ORB	steel	17.88	1.77	45.0	1.23	31.2	1-1/16"	0.25	5	25
1/2"	AG4F6-PV	3/4" - 14 NPTF	steel	19.08	1.77	45.0	1.37	34.8	1-3/16"	0.25	5	25
3/4"	AG6F6-PV	3/4" - 14 NPTF	steel	32.19	2.20	56.0	1.58	40.1	1-3/8"	0.50	-	10
1"	AG8F8-PV	1" - 11 1/2 NPTF	steel	47.68	2.48	63.0	1.87	47.5	1-5/8"	0.62	-	10



Body Size	AG-Series Agricultural Interchange Coupler Dust Plug						
	Part Detail			List Price	Weight Lb	Package Qty	
	Part Number	Lanyard	Body			Bag	Box
1/4"	2AGDP	Elastomer	Elastomer	\$4.35	0.02	10	50
3/8"	3AGDP	Elastomer	Elastomer	6.26	0.04	10	50
1/2"	For 1/2" Please refer to the color coded K-Series Dust Plugs on pg. 78						
3/4"	6AGDP	Elastomer	Elastomer	9.45	0.07	5	25
1"	8AGDP	Elastomer	Elastomer	10.88	0.10	5	25



Body Size	AG-Series Agricultural Interchange Nipple Dust Cap						
	Part Detail			List Price	Weight Lb	Package Qty	
	Part Number	Lanyard	Body			Bag	Box
1/4"	AG2DC	Elastomer	Elastomer	\$4.56	0.02	10	50
3/8"	AG3DC	Elastomer	Elastomer	5.25	0.04	10	50
1/2"	For 1/2" Please refer to the color coded K-Series Dust Caps on pg. 78						
3/4"	AG6DC	Elastomer	Elastomer	13.15	0.07	5	25
1"	AG8DC	Elastomer	Elastomer	15.07	0.10	5	25

# V-Series Hydraulic Couplings

## Interchange Data:

- Interchangeable to MIL-C-51234
- Snap-Tite H/IH and Faster TNV/TNL

## Materials:

- Machined components are manufactured using solid steel, brass, or 316 stainless steel bar stock.
- Stainless steel balls, retaining rings, and springs maximize corrosion resistance and extend service life.
- Steel componentry is plated using ROHS Compliant Trivalent Chrome.
- Steel coupler sleeves are hardened to resist deformation and maximize service life.
- Steel nipples are machined from high-strength steel and induction hardened.
- Tubular 'TV' valves are constructed from steel bar stock and are designed for optimum performance in pneumatic applications.

## Seal Components:

- Nitrile (Buna-N) seals are standard, providing a temperature range of -40°F to +250°F (-40°C to +121°C).
- All couplers incorporate a PTFE anti-extrusion ring to protect the seal components from dynamic impulse damage.
- 1/4" to 1" valve seals are crimped in place to maintain integrity during excessive flow conditions and pressurized connection.
- 1 1/4" to 2" valve O-rings are retained by a unique seal-groove profile and are field replaceable.

Note: Air flow data is presented using a coupler with a 'TV' valve and unvalved nipple. This configuration provides the optimal performance for pneumatic applications.

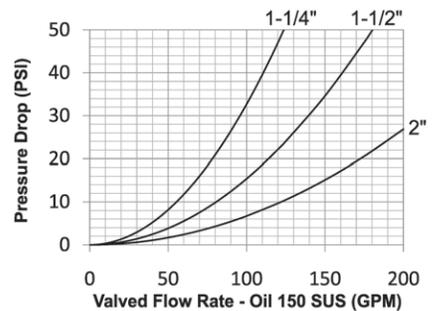
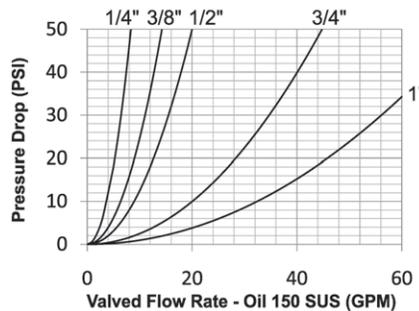
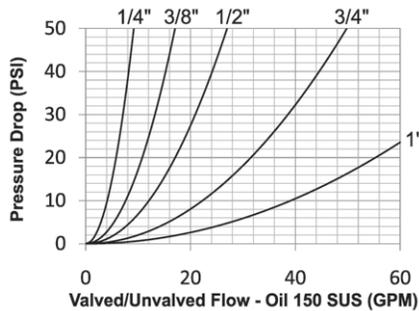
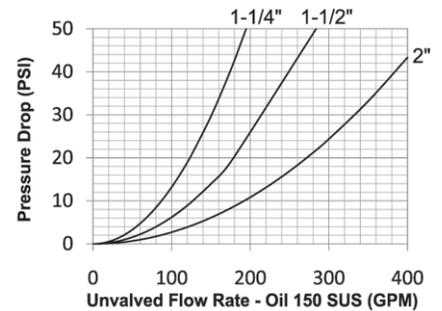
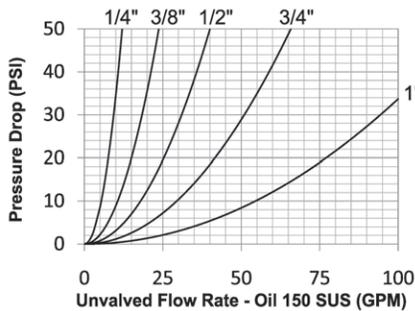
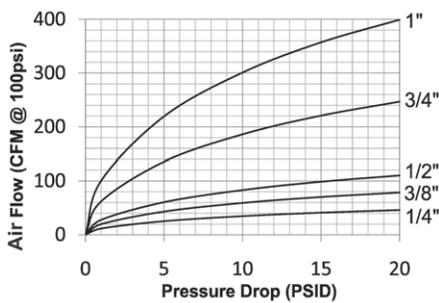

## V Series Profiles

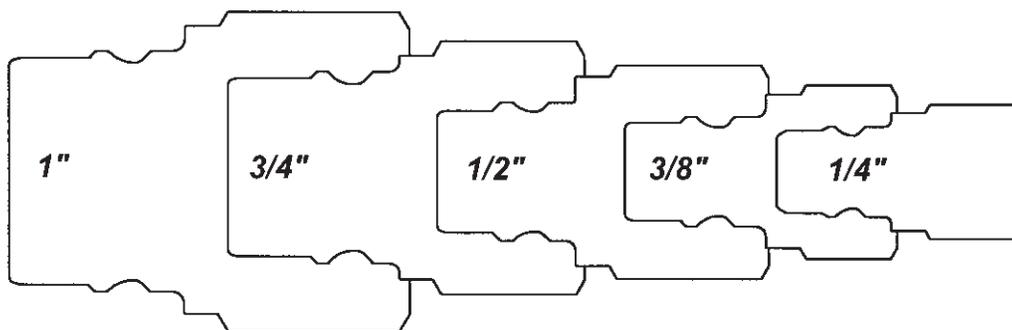

## V-Series Hydraulic Couplings

### Rated Pressure Chart:

Body Size	V-Series Snap-Tite H/IH Interchange (Valved Connected)											
	Steel Coupler/Plug				Brass Coupler/Plug				316 Stainless Coupler/Plug			
	Maximum Working		Burst		Maximum Working		Burst		Maximum Working		Burst	
	PSI	Bar	PSI	Bar	PSI	Bar	PSI	Bar	PSI	Bar	PSI	Bar
1/4"	6,500	450	12,700	876	2,250	150	5,000	345	5,000	345	10,000	700
3/8"	4,500	310	10,500	700	2,250	150	5,300	350	4,000	275	8,000	550
1/2"	4,000	275	9,600	650	2,000	130	5,700	390	3,750	260	7,500	500
3/4"	3,500	240	9,100	600	2,000	130	5,300	350	2,000	130	7,500	500
1"	2,000	130	9,500	650	1,750	120	5,000	345	2,000	130	5,000	345
1-1/4"	1,750	120	5,000	345	350	24	1,000	70	1,500	100	3,000	200
1-1/2"	1,500	100	5,000	345	350	24	1,200	80	1,500	100	3,000	200
2"	1,500	100	4,000	275	400	28	1,000	70	500	34	1,000	70

Body Size	V-Series Snap-Tite H/IH Interchange (Unvalved Connected)											
	Steel Coupler/Plug				Brass Coupler/Plug				316 SS Coupler/Plug			
	Maximum Working		Burst		Maximum Working		Burst		Maximum Working		Burst	
	PSI	Bar	PSI	Bar	PSI	Bar	PSI	Bar	PSI	Bar	PSI	Bar
1/4"	11,000	760	29,500	2,000	4,000	275	14,200	980	10,000	670	29,200	2,000
3/8"	11,000	760	29,900	2,000	4,000	275	14,500	1,000	8,000	550	27,900	1,900
1/2"	11,000	760	29,300	2,000	4,000	275	14,500	1,000	8,000	550	24,600	1,700
3/4"	9,000	620	19,300	1,300	3,500	250	11,100	750	7,000	480	22,600	1,500
1"	6,000	400	15,900	1,100	3,000	200	8,200	560	4,000	275	15,500	1,000
1-1/4"	5,000	345	10,000	700	1,000	70	4,000	275	3,000	200	10,000	700
1-1/2"	5,000	345	10,000	700	1,000	70	4,000	275	3,000	200	10,000	700
2"	4,000	275	8,000	550	750	50	2,800	190	1,000	70	6,000	400

### Technical Specifications:

Body Size	Interchange Standards			Functional Parameters				
	U.S. Military	International Standards	ANSI/NFPA Standards	Locking Ball Quantity	Air Inclusion	Fluid Loss	Vacuum Inch HG	Flow $\Delta P = 22$ PSI
1/4"	MIL-C-51234	-	-	6	2.0cc	0.2cc	26.7	5.5 GPM
3/8"	MIL-C-51234	-	-	6	3.5cc	3.2cc	26.7	9.5 GPM
1/2"	MIL-C-51234	-	-	9	4.0cc	4.0cc	26.7	13 GPM
3/4"	MIL-C-51234	-	-	9	14.0cc	14.0cc	26.7	30 GPM
1"	MIL-C-51234	-	-	12	21.0cc	20.0cc	26.7	48 GPM
1-1/4"	MIL-C-51234	-	-	12	45.0cc	45.0cc	N/R	82 GPM
1-1/2"	MIL-C-51234	-	-	12	80.0cc	80.0cc	N/R	120 GPM
2"	MIL-C-51234	-	-	12	150.0cc	150.0cc	N/R	185 GPM

Note: Minimum burst pressure ratings were established under laboratory conditions using a Static Burst Unit (SBU). For high impulse applications and to meet Det Norske Veritas (DNV) compliance, the operating pressure must be divided by two (2) to ensure a 4:1 safety factor during system operation.

## V-Series Hydraulic Couplings

### List Price Seal Option Adders:

Body Size	Standard Seal Options												Kalrez® Seal Options							
	FKM		EPDM		Steam-EP		FDA FKM		Mil-Nitrile		Fuel Nitrile		Silicone		4079		6375		7075	
	Pre	Add \$	Pre	Add \$	Pre	Add \$	Pre	Add \$	Pre	Add \$	Pre	Add \$	Pre	Add \$	Pre	Add \$	Pre	Add \$	Pre	Add \$
1/4"	F-	\$0.00	P-	\$3.82	PS-	\$3.82	D-	\$3.82	M-	\$3.74	JF-	\$4.05	S-	\$3.82	K4-	POR	K6-	POR	K7-	POR
3/8"	F-	.00	P-	5.29	PS-	5.29	D-	5.29	M-	5.17	JF-	5.56	S-	5.29	K4-	POR	K6-	POR	K7-	POR
1/2"	F-	.00	P-	5.74	PS-	5.74	D-	4.93	M-	4.48	JF-	4.93	S-	4.93	K4-	POR	K6-	POR	K7-	POR
3/4"	F-	.00	P-	6.29	PS-	6.29	D-	5.67	M-	5.52	JF-	5.67	S-	5.67	K4-	POR	K6-	POR	K7-	POR
1"	F-	.00	P-	6.76	PS-	6.76	D-	6.47	M-	6.34	JF-	6.47	S-	6.47	K4-	POR	K6-	POR	K7-	POR
1-1/4"	F-	.00	P-	11.03	PS-	11.03	D-	10.06	M-	9.84	JF-	10.06	S-	10.06	K4-	POR	K6-	POR	K7-	POR
1-1/2"	F-	.00	P-	11.03	PS-	11.03	D-	10.06	M-	9.84	JF-	10.06	S-	10.06	K4-	POR	K6-	POR	K7-	POR
2"	F-	.00	P-	12.91	PS-	12.91	D-	11.46	M-	10.15	JF-	11.46	S-	11.46	K4-	POR	K6-	POR	K7-	POR

### List Price Option Adders:

Body Size	Valve Options									Sleeve Options						Treatments			
	Unvalved		Tubular		Steel		Brass		316 SS		Sleeve-Lock		Flanged		Sil-Flange		Oxy-Clean		
	Suf	Add \$	Suf	Add \$	Suf	Add \$	Suf	Add \$	Suf	Add \$	Suf	Add \$	Suf	Add \$	Suf	Add \$	Suf	Add \$	Suf
1/4"	-E	-	-TV	\$2.40	-ZV	\$0.00	-BV	\$0.00	SSV	\$2.60	-LS	\$4.20	-FS	N/A	FSB	N/A	-C1	\$12.00	
3/8"	-E	-	-TV	2.40	-ZV	.00	-BV	.00	SSV	2.70	-LS	4.90	-FS	N/A	FSB	N/A	-C1	12.00	
1/2"	-E	-	-TV	2.40	-ZV	.00	-BV	.00	SSV	4.80	-LS	5.50	-FS	N/A	FSB	N/A	-C1	14.00	
3/4"	-E	-	-TV	2.40	-ZV	.00	-BV	.00	SSV	6.00	-LS	6.60	-FS	N/A	FSB	N/A	-C1	14.00	
1"	-E	-	-TV	2.40	-ZV	.00	-BV	.00	SSV	8.80	-LS	10.00	-FS	N/A	FSB	N/A	-C1	16.00	
1-1/4"	-E	-	-TV	N/A	-ZV	.00	-BV	.00	SSV	32.55	-LS	19.00	-FS	N/A	FSB	N/A	-C1	20.00	
1-1/2"	-E	-	-TV	N/A	-ZV	.00	-BV	.00	SSV	38.20	-LS	26.50	-FS	N/A	FSB	N/A	-C1	20.00	
2"	-E	-	-TV	N/A	-ZV	.00	-BV	.00	SSV	46.90	-LS	26.50	-FS	N/A	FSB	N/A	-C1	20.00	

### Large V Series Profiles



## V-Series Hydraulic Couplings

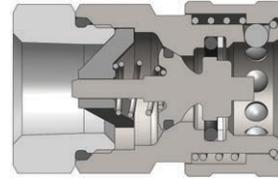

Body Size	V-Series Snap-Tite H/IH Interchange Valved Coupler (Female Threads)											
	Part Detail			List Price	Length		Maximum OD		Hex Inch	Weight Lb	Package Qty	
	Part Number	Threads	Material		Inch	mm	Inch	mm			Bag	Box
1/4"	2VF1	1/8" - 27 NPTF	steel	\$25.60	1.68	42.7	0.99	25.1	7/8"	0.22	5	50
1/4"	2VF2	1/4" - 18 NPTF	steel	24.39	1.68	42.7	0.99	25.1	7/8"	0.20	5	50
1/4"	2VF2-B	1/4" - 18 NPTF	brass	30.55	1.68	42.7	0.99	25.1	7/8"	0.20	5	50
1/4"	2VF2-SS	1/4" - 18 NPTF	316 stainless	104.32	1.68	42.7	0.99	25.1	7/8"	0.20	5	50
1/4"	2VBF2	1/4" - 19 BSPP	steel	24.39	1.81	46.0	0.99	25.1	7/8"	0.20	5	50
1/4"	2VBF2-B	1/4" - 19 BSPP	brass	30.55	1.81	46.0	0.99	25.1	7/8"	0.20	5	50
1/4"	2VBF2-SS	1/4" - 19 BSPP	316 stainless	104.32	1.81	46.0	0.99	25.1	7/8"	0.20	5	50
1/4"	2VOF2	7/16" - 20 ORB	steel	25.41	1.81	46.0	0.99	25.1	7/8"	0.23	5	50
3/8"	3VF3	3/8" - 18 NPTF	steel	33.27	1.94	49.3	1.18	30.0	1"	0.37	5	50
3/8"	3VF3-B	3/8" - 18 NPTF	brass	39.72	1.94	49.3	1.18	30.0	1"	0.37	5	50
3/8"	3VF3-SS	3/8" - 18 NPTF	316 stainless	149.79	1.94	49.3	1.18	30.0	1"	0.38	5	50
3/8"	3VBF3	3/8" - 19 BSPP	steel	33.27	2.01	51.1	1.18	30.0	1"	0.37	5	50
3/8"	3VBF3-B	3/8" - 19 BSPP	brass	39.73	2.01	51.1	1.18	30.0	1"	0.37	5	50
3/8"	3VBF3-SS	3/8" - 19 BSPP	316 stainless	149.79	2.01	51.1	1.18	30.0	1"	0.38	5	50
3/8"	3VOF3	9/16" - 18 ORB	steel	35.97	2.01	51.1	1.18	30.0	1"	0.40	5	50
3/8"	3VF4	1/2" - 14 NPTF	steel	42.75	2.01	51.1	1.18	30.0	1"	0.49	5	50
1/2"	4VF4	1/2" - 14 NPTF	steel	40.44	2.13	54.1	1.36	34.5	1-3/16"	0.49	5	25
1/2"	4VF4-B	1/2" - 14 NPTF	brass	58.18	2.13	54.1	1.36	34.5	1-3/16"	0.49	5	25
1/2"	4VF4-SS	1/2" - 14 NPTF	316 stainless	206.42	2.13	54.1	1.36	34.5	1-3/16"	0.52	5	25
1/2"	4VBF4	1/2" - 14 BSPP	steel	40.44	2.13	54.1	1.36	34.5	1-3/16"	0.49	5	25
1/2"	4VBF4-B	1/2" - 14 BSPP	brass	58.20	2.13	54.1	1.36	34.5	1-3/16"	0.49	5	25
1/2"	4VBF4-SS	1/2" - 14 BSPP	316 stainless	206.42	2.13	54.1	1.36	34.5	1-3/16"	0.52	5	25
1/2"	4VOF4	3/4" - 16 ORB	steel	43.51	2.13	54.1	1.36	34.5	1-3/16"	0.54	5	25
1/2"	4VF6	3/4" - 14 NPTF	steel	48.41	2.13	54.1	1.36	34.5	1-3/16"	0.58	5	25
3/4"	6VF6	3/4" - 14 NPTF	steel	62.58	2.47	62.7	1.67	42.4	1-1/2"	0.88	5	20
3/4"	6VF6-B	3/4" - 14 NPTF	brass	90.33	2.47	62.7	1.67	42.4	1-1/2"	0.88	5	20
3/4"	6VF6-SS	3/4" - 14 NPTF	316 stainless	295.52	2.47	62.7	1.67	42.4	1-1/2"	0.94	5	20
3/4"	6VBF6	3/4" - 14 BSPP	steel	62.58	2.96	75.2	1.67	42.4	1-1/2"	0.88	5	20
3/4"	6VBF6-B	3/4" - 14 BSPP	brass	90.33	2.96	75.2	1.67	42.4	1-1/2"	0.88	5	20
3/4"	6VBF6-SS	3/4" - 14 BSPP	316 stainless	295.52	2.96	75.2	1.67	42.4	1-1/2"	0.94	5	20
3/4"	6VOF6	1-1/16" - 12 ORB	steel	73.01	2.96	75.2	1.67	42.4	1-1/2"	0.99	5	20
1"	8VF8	1" - 11 1/2 NPTF	steel	97.23	2.70	68.6	2.06	52.3	1-7/8"	1.33	-	10
1"	8VF8-B	1" - 11 1/2 NPTF	brass	140.99	2.70	68.6	2.06	52.3	1-7/8"	1.33	-	10
1"	8VF8-SS	1" - 11 1/2 NPTF	316 stainless	455.47	2.70	68.6	2.06	52.3	1-7/8"	1.33	-	10
1"	8VBF8	1" - 11 BSPP	steel	97.12	2.97	75.4	2.06	52.3	1-7/8"	1.33	-	10
1"	8VBF8-B	1" - 11 BSPP	brass	140.99	2.97	75.4	2.06	52.3	1-7/8"	1.33	-	10
1"	8VBF8-SS	1" - 11 BSPP	316 stainless	455.47	2.97	75.4	2.06	52.3	1-7/8"	1.33	-	10
1"	8VOF8	1-5/16" - 12 ORB	steel	115.12	2.97	75.4	2.06	52.3	1-7/8"	1.42	-	10



## V-Series Hydraulic Couplings

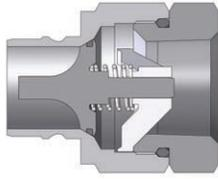

Body Size	V-Series Snap-Tite H/IH Interchange Valved Nipple (Female Threads)											
	Part Detail			List Price	Length		Maximum OD		Hex Inch	Weight Lb	Package Qty	
	Part Number	Threads	Material		Inch	mm	Inch	mm			Bag	Box
1/4"	V2F1	1/8" - 27 NPTF	steel	<b>\$18.08</b>	1.62	41.1	0.97	24.6	7/8"	0.17	5	50
1/4"	V2F2	1/4" - 18 NPTF	steel	<b>16.72</b>	1.62	41.1	0.97	24.6	7/8"	0.14	5	50
1/4"	V2F2-B	1/4" - 18 NPTF	brass	<b>21.77</b>	1.62	41.1	0.97	24.6	7/8"	0.14	5	50
1/4"	V2F2-SS	1/4" - 18 NPTF	316 stainless	<b>72.77</b>	1.62	41.1	0.97	24.6	7/8"	0.15	5	50
1/4"	V2BF2	1/4" - 19 BSPP	steel	<b>16.72</b>	1.75	44.5	0.97	24.6	7/8"	0.14	5	50
1/4"	V2BF2-B	1/4" - 19 BSPP	brass	<b>21.77</b>	1.75	44.5	0.97	24.6	7/8"	0.14	5	50
1/4"	V2BF2-SS	1/4" - 19 BSPP	316 stainless	<b>72.77</b>	1.75	44.5	0.97	24.6	7/8"	0.14	5	50
1/4"	V2OF2	7/16" - 20 ORB	steel	<b>18.78</b>	1.75	44.5	0.97	24.6	7/8"	0.16	5	50
3/8"	V3F3	3/8" - 18 NPTF	steel	<b>20.85</b>	1.87	47.5	1.10	27.9	1"	0.23	5	50
3/8"	V3F3-B	3/8" - 18 NPTF	brass	<b>30.55</b>	1.87	47.5	1.10	27.9	1"	0.23	5	50
3/8"	V3F3-SS	3/8" - 18 NPTF	316 stainless	<b>106.93</b>	1.87	47.5	1.10	27.9	1"	0.23	5	50
3/8"	V3BF3	3/8" - 19 BSPP	steel	<b>20.84</b>	1.94	49.3	1.10	27.9	1"	0.23	5	50
3/8"	V3BF3-B	3/8" - 19 BSPP	brass	<b>30.55</b>	1.94	49.3	1.10	27.9	1"	0.23	5	50
3/8"	V3BF3-SS	3/8" - 19 BSPP	316 stainless	<b>106.93</b>	1.94	49.3	1.10	27.9	1"	0.23	5	50
3/8"	V3OF3	9/16" - 18 ORB	steel	<b>23.53</b>	1.94	49.3	1.10	27.9	1"	0.25	5	50
3/8"	V3F4	1/2" - 14 NPTF	steel	<b>29.57</b>	1.94	49.3	1.10	27.9	1"	0.27	5	50
1/2"	V4F4	1/2" - 14 NPTF	steel	<b>24.91</b>	1.99	50.5	1.31	33.3	1-3/16"	0.30	5	25
1/2"	V4F4-B	1/2" - 14 NPTF	brass	<b>40.62</b>	1.99	50.5	1.31	33.3	1-3/16"	0.30	5	25
1/2"	V4F4-SS	1/2" - 14 NPTF	316 stainless	<b>147.03</b>	1.99	50.5	1.31	33.3	1-3/16"	0.30	5	25
1/2"	V4BF4	1/2" - 14 BSPP	steel	<b>24.92</b>	1.99	50.5	1.31	33.3	1-3/16"	0.30	5	25
1/2"	V4BF4-B	1/2" - 14 BSPP	brass	<b>40.62</b>	1.99	50.5	1.31	33.3	1-3/16"	0.30	5	25
1/2"	V4BF4-SS	1/2" - 14 BSPP	316 stainless	<b>147.03</b>	1.99	50.5	1.31	33.3	1-3/16"	0.30	5	25
1/2"	V4OF4	3/4" - 16 ORB	steel	<b>27.97</b>	1.99	50.5	1.31	33.3	1-3/16"	0.33	5	25
1/2"	V4F6	3/4" - 14 NPTF	steel	<b>41.40</b>	1.99	50.5	1.31	33.3	1-3/16"	0.38	5	25
3/4"	V6F6	3/4" - 14 NPTF	steel	<b>37.36</b>	2.31	58.7	1.65	41.9	1-1/2"	0.60	5	20
3/4"	V6F6-B	3/4" - 14 NPTF	brass	<b>52.54</b>	2.31	58.7	1.65	41.9	1-1/2"	0.60	5	20
3/4"	V6F6-SS	3/4" - 14 NPTF	316 stainless	<b>202.48</b>	2.31	58.7	1.65	41.9	1-1/2"	0.59	5	20
3/4"	V6BF6	3/4" - 14 BSPP	steel	<b>37.36</b>	2.80	71.1	1.65	41.9	1-1/2"	0.60	5	20
3/4"	V6BF6-B	3/4" - 14 BSPP	brass	<b>52.54</b>	2.80	71.1	1.65	41.9	1-1/2"	0.60	5	20
3/4"	V6BF6-SS	3/4" - 14 BSPP	316 stainless	<b>202.48</b>	2.80	71.1	1.65	41.9	1-1/2"	0.61	5	20
3/4"	V6OF6	1-1/16" - 12 ORB	steel	<b>47.75</b>	2.80	71.1	1.65	41.9	1-1/2"	0.66	5	20
1"	V8F8	1" - 11 1/2 NPTF	steel	<b>59.70</b>	2.60	66.0	2.06	52.3	1-7/8"	0.93	-	10
1"	V8F8-B	1" - 11 1/2 NPTF	brass	<b>101.47</b>	2.60	66.0	2.06	52.3	1-7/8"	0.93	-	10
1"	V8F8-SS	1" - 11 1/2 NPTF	316 stainless	<b>330.38</b>	2.60	66.0	2.06	52.3	1-7/8"	0.94	-	10
1"	V8BF8	1" - 11 BSPP	steel	<b>59.70</b>	2.87	72.9	2.06	52.3	1-7/8"	0.93	-	10
1"	V8BF8-B	1" - 11 BSPP	brass	<b>101.46</b>	2.87	72.9	2.06	52.3	1-7/8"	0.94	-	10
1"	V8BF8-SS	1" - 11 BSPP	316 stainless	<b>330.38</b>	2.87	72.9	2.06	52.3	1-7/8"	0.93	-	10
1"	V8OF8	1-5/16" - 12 ORB	steel	<b>70.67</b>	2.857	72.6	2.06	52.3	1-7/8"	0.98	-	10

## V-Series Hydraulic Couplings

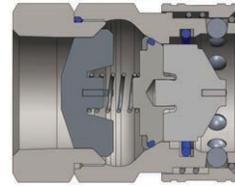

Body Size	V-Series Snap-Tite H/IH Interchange Valved Coupler (Female Threads)											
	Part Detail			List Price	Length		Maximum OD		Hex Inch	Weight Lb	Package Qty	
	Part Number	Threads	Material		Inch	mm	Inch	mm			Bag	Box
1-1/4"	10VF10	1-1/4" - 11 1/2 NPTF	steel	<b>\$230.41</b>	3.54	89.9	2.19	55.6	2"	1.94	-	10
1-1/4"	10VF10-B	1-1/4" - 11 1/2 NPTF	brass	<b>289.79</b>	3.54	89.9	2.19	55.6	2"	1.94	-	10
1-1/4"	10VF10-SS	1-1/4" - 11 1/2 NPTF	316 stainless	<b>752.83</b>	3.54	89.9	2.19	55.6	2"	1.95	-	10
1-1/4"	10VBF10	1-1/4" - 11 BSPP	steel	<b>230.41</b>	3.54	89.9	2.19	55.6	2"	1.94	-	10
1-1/4"	10VBF10-B	1-1/4" - 11 BSPP	brass	<b>289.79</b>	3.54	89.9	2.19	55.6	2"	1.94	-	10
1-1/4"	10VBF10-SS	1-1/4" - 11 BSPP	316 stainless	<b>796.86</b>	3.54	89.9	2.19	55.6	2"	1.95	-	10
1-1/4"	10VOF10	1-5/8" - 12 ORB	steel	<b>267.81</b>	3.54	89.9	2.19	55.6	2"	1.92	-	10
1-1/2"	12VF12	1-1/2" - 11 1/2 NPTF	steel	<b>318.61</b>	3.27	83.1	2.74	69.6	2-1/2"	2.95	-	5
1-1/2"	12VF12-B	1-1/2" - 11 1/2 NPTF	brass	<b>402.31</b>	3.27	83.1	2.74	69.6	2-1/2"	2.95	-	5
1-1/2"	12VF12-SS	1-1/2" - 11 1/2 NPTF	316 stainless	<b>1022.29</b>	3.27	83.1	2.74	69.6	2-1/2"	2.94	-	5
1-1/2"	12VBF12	1-1/2" - 11 BSPP	steel	<b>318.61</b>	3.27	83.1	2.74	69.6	2-1/2"	2.95	-	5
1-1/2"	12VBF12-B	1-1/2" - 11 BSPP	brass	<b>402.31</b>	3.27	83.1	2.74	69.6	2-1/2"	2.95	-	5
1-1/2"	12VBF12-SS	1-1/2" - 11 BSPP	316 stainless	<b>1082.13</b>	3.27	83.1	2.74	69.6	2-1/2"	2.95	-	5
1-1/2"	12VOF12	1-7/8" - 12 ORB	steel	<b>377.35</b>	3.27	83.1	2.74	69.6	2-1/2"	3.01	-	5
2"	16VF16	2" - 11 1/2 NPTF	steel	<b>605.88</b>	3.92	99.6	3.83	97.3	3-1/2"	6.19	-	5
2"	16VF16-B	2" - 11 1/2 NPTF	brass	<b>852.55</b>	3.92	99.6	3.83	97.3	3-1/2"	6.19	-	5
2"	16VF16-SS	2" - 11 1/2 NPTF	316 stainless	<b>1832.84</b>	3.92	99.6	3.83	97.3	3-1/2"	6.20	-	5
2"	16VBF16	2" - 11 BSPP	steel	<b>663.75</b>	3.92	99.6	3.83	97.3	3-1/2"	6.19	-	5
2"	16VBF16-B	2" - 11 BSPP	brass	<b>852.55</b>	3.92	99.6	3.83	97.3	3-1/2"	6.19	-	5
2"	16VBF16-SS	2" - 11 BSPP	316 stainless	<b>1940.06</b>	3.92	99.6	3.83	97.3	3-1/2"	6.19	-	5

## V-Series Hydraulic Couplings

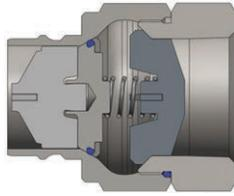

Body Size	V-Series Snap-Tite H/IH Interchange Valved Nipple (Female Threads)											
	Part Detail			List Price	Length		Maximum OD		Hex Inch	Weight Lb	Package Qty	
	Part Number	Threads	Material		Inch	mm	Inch	mm			Bag	Box
1-1/4"	V10F10	1-1/4" - 11 1/2 NPTF	steel	<b>\$187.11</b>	3.41	86.6	2.19	55.6	2"	0.52	-	10
1-1/4"	V10F10-B	1-1/4" - 11 1/2 NPTF	brass	<b>204.90</b>	3.41	86.6	2.19	55.6	2"	0.52	-	10
1-1/4"	V10F10-SS	1-1/4" - 11 1/2 NPTF	316 stainless	<b>548.66</b>	3.41	86.6	2.19	55.6	2"	0.50	-	10
1-1/4"	V10BF10	1-1/4" - 11 BSPP	steel	<b>187.11</b>	3.41	86.6	2.19	55.6	2"	0.52	-	10
1-1/4"	V10BF10-B	1-1/4" - 11 BSPP	brass	<b>195.14</b>	3.41	86.6	2.19	55.6	2"	0.52	-	10
1-1/4"	V10BF10-SS	1-1/4" - 11 BSPP	316 stainless	<b>548.67</b>	3.41	86.6	2.19	55.6	2"	0.51	-	10
1-1/4"	V10OF10	1-5/8" - 12 ORB	steel	<b>209.99</b>	3.41	86.6	2.19	55.6	2"	0.59	-	10
1-1/2"	V12F12	1-1/2" - 11 1/2 NPTF	steel	<b>229.77</b>	3.11	79.0	2.74	69.6	2-1/2"	2.13	-	5
1-1/2"	V12F12-B	1-1/2" - 11 1/2 NPTF	brass	<b>271.65</b>	3.11	79.0	2.74	69.6	2-1/2"	2.13	-	5
1-1/2"	V12F12-SS	1-1/2" - 11 1/2 NPTF	316 stainless	<b>765.07</b>	3.11	79.0	2.74	69.6	2-1/2"	2.12	-	5
1-1/2"	V12BF12	1-1/2" - 11 BSPP	steel	<b>229.77</b>	3.11	79.0	2.74	69.6	2-1/2"	2.13	-	5
1-1/2"	V12BF12-B	1-1/2" - 11 BSPP	brass	<b>271.65</b>	3.11	79.0	2.74	69.6	2-1/2"	2.14	-	5
1-1/2"	V12BF12-SS	1-1/2" - 11 BSPP	316 stainless	<b>765.07</b>	3.11	79.0	2.74	69.6	2-1/2"	2.14	-	5
1-1/2"	V12OF12	1-7/8" - 12 ORB	steel	<b>268.10</b>	3.11	79.0	2.74	69.6	2-1/2"	2.21	-	5
2"	V16F16	2" - 11 1/2 NPTF	steel	<b>438.03</b>	3.72	94.5	3.83	97.3	3-1/2"	4.75	-	5
2"	V16F16-B	2" - 11 1/2 NPTF	brass	<b>576.59</b>	3.72	94.5	3.83	97.3	3-1/2"	4.75	-	5
2"	V16F16-SS	2" - 11 1/2 NPTF	316 stainless	<b>1418.38</b>	3.72	94.5	3.83	97.3	3-1/2"	4.76	-	5
2"	V16BF16	2" - 11 BSPP	steel	<b>479.90</b>	3.72	94.5	3.83	97.3	3-1/2"	4.75	-	5
2"	V16BF16-B	2" - 11 BSPP	brass	<b>576.59</b>	3.72	94.5	3.83	97.3	3-1/2"	4.75	-	5
2"	V16BF16-SS	2" - 11 BSPP	316 stainless	<b>1501.38</b>	3.72	94.5	3.83	97.3	3-1/2"	4.73	-	5

## V-Series Hydraulic Couplings

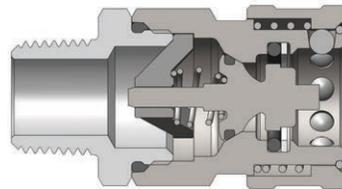

Body Size	V-Series Snap-Tite H/IH Interchange Valved Coupler (Male Threads)											
	Part Detail			List Price	Length		Maximum OD		Hex Inch	Weight Lb	Package Qty	
	Part Number	Threads	Material		Inch	mm	Inch	mm			Bag	Box
1/4"	2VM1	1/8" - 27 NPTF	steel	<b>\$27.66</b>	2.12	53.8	0.99	25.1	7/8"	0.21	5	50
1/4"	2VM2	1/4" - 18 NPTF	steel	<b>25.75</b>	2.12	53.8	0.99	25.1	7/8"	0.23	5	50
1/4"	2VM2-B	1/4" - 18 NPTF	brass	<b>31.32</b>	2.12	53.8	0.99	25.1	7/8"	0.22	5	50
1/4"	2VM2-SS	1/4" - 18 NPTF	316 stainless	<b>118.42</b>	2.12	53.8	0.99	25.1	7/8"	0.23	5	50
3/8"	3VM3	3/8" - 18 NPTF	steel	<b>37.36</b>	2.32	58.9	1.18	30.0	1"	0.24	5	50
3/8"	3VM3-B	3/8" - 18 NPTF	brass	<b>40.61</b>	2.32	58.9	1.18	30.0	1"	0.24	5	50
3/8"	3VM3-SS	3/8" - 18 NPTF	316 stainless	<b>161.46</b>	2.32	58.9	1.18	30.0	1"	0.26	5	50
1/2"	4VM4	1/2" - 14 NPTF	steel	<b>42.49</b>	2.54	64.5	1.36	34.5	1-3/16"	0.48	5	25
1/2"	4VM4-B	1/2" - 14 NPTF	brass	<b>59.30</b>	2.54	64.5	1.36	34.5	1-3/16"	0.47	5	25
1/2"	4VM4-SS	1/2" - 14 NPTF	316 stainless	<b>240.57</b>	2.54	64.5	1.36	34.5	1-3/16"	0.47	5	25
3/4"	6VM6	3/4" - 14 NPTF	steel	<b>64.99</b>	3.07	78.0	1.67	42.4	1-1/2"	0.92	5	20
3/4"	6VM6-B	3/4" - 14 NPTF	brass	<b>90.33</b>	3.07	78.0	1.67	42.4	1-1/2"	0.91	5	20
3/4"	6VM6-SS	3/4" - 14 NPTF	316 stainless	<b>371.04</b>	3.07	78.0	1.67	42.4	1-1/2"	0.91	5	20
1"	8VM8	1" - 11 1/2 NPTF	steel	<b>109.31</b>	3.32	84.3	2.06	52.3	1-7/8"	1.35	-	10
1"	8VM8-B	1" - 11 1/2 NPTF	brass	<b>172.95</b>	3.32	84.3	2.06	52.3	1-7/8"	1.32	-	10
1"	8VM8-SS	1" - 11 1/2 NPTF	316 stainless	<b>491.14</b>	3.32	84.3	2.06	52.3	1-7/8"	1.38	-	10
1-1/4"	10VM10	1-1/4" - 11 1/2 NPTF	steel	<b>257.93</b>	3.59	91.2	2.19	55.6	2"	1.84	-	10
1-1/4"	10VM10-B	1-1/4" - 11 1/2 NPTF	brass	<b>361.02</b>	3.59	91.2	2.19	55.6	2"	1.78	-	10
1-1/4"	10VM10-SS	1-1/4" - 11 1/2 NPTF	316 stainless	<b>837.56</b>	3.59	91.2	2.19	55.6	2"	1.79	-	10
1-1/2"	12VM12	1-1/2" - 11 1/2 NPTF	steel	<b>364.68</b>	4.01	101.9	2.74	69.6	2-1/2"	2.98	-	5
1-1/2"	12VM12-B	1-1/2" - 11 1/2 NPTF	brass	<b>509.11</b>	4.01	101.9	2.74	69.6	2-1/2"	2.95	-	5
1-1/2"	12VM12-SS	1-1/2" - 11 1/2 NPTF	316 stainless	<b>1244.45</b>	4.01	101.9	2.74	69.6	2-1/2"	2.95	-	5
2"	16VM16	2" - 11 1/2 NPTF	steel	<b>675.32</b>	4.54	115.3	3.83	97.3	3-1/2"	6.01	-	5
2"	16VM16-B	2" - 11 1/2 NPTF	brass	<b>898.96</b>	4.54	115.3	3.83	97.3	3-1/2"	6.00	-	5
2"	16VM16-SS	2" - 11 1/2 NPTF	316 stainless	<b>1940.06</b>	4.54	115.3	3.83	97.3	3-1/2"	6.09	-	5

## V-Series Hydraulic Couplings

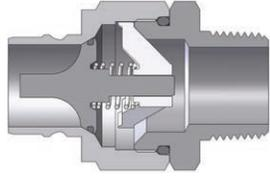

Body Size	V-Series Snap-Tite H/IH Interchange Valved Nipple (Male Threads)											
	Part Detail			List Price	Length		Maximum OD		Hex Inch	Weight Lb	Package Qty	
	Part Number	Threads	Material		Inch	mm	Inch	mm			Bag	Box
1/4"	V2M1	1/8" - 27 NPTF	steel	<b>\$20.10</b>	2.06	52.3	0.97	24.6	7/8"	0.15	5	50
1/4"	V2M2	1/4" - 18 NPTF	steel	<b>18.08</b>	2.06	52.3	0.97	24.6	7/8"	0.16	5	50
1/4"	V2M2-B	1/4" - 18 NPTF	brass	<b>22.97</b>	2.06	52.3	0.97	24.6	7/8"	0.16	5	50
1/4"	V2M2-SS	1/4" - 18 NPTF	316 stainless	<b>86.84</b>	2.06	52.3	0.97	24.6	7/8"	0.16	5	50
3/8"	V3M3	3/8" - 18 NPTF	steel	<b>22.53</b>	2.25	57.2	1.10	27.9	1"	0.21	5	50
3/8"	V3M3-B	3/8" - 18 NPTF	brass	<b>31.88</b>	2.25	57.2	1.10	27.9	1"	0.21	5	50
3/8"	V3M3-SS	3/8" - 18 NPTF	316 stainless	<b>118.59</b>	2.25	57.2	1.10	27.9	1"	0.21	5	50
1/2"	V4M4	1/2" - 14 NPTF	steel	<b>26.96</b>	2.40	61.0	1.31	33.3	1-3/16"	0.31	5	25
1/2"	V4M4-B	1/2" - 14 NPTF	brass	<b>42.45</b>	2.40	61.0	1.31	33.3	1-3/16"	0.31	5	25
1/2"	V4M4-SS	1/2" - 14 NPTF	316 stainless	<b>181.16</b>	2.40	61.0	1.31	33.3	1-3/16"	0.33	5	25
3/4"	V6M6	3/4" - 14 NPTF	steel	<b>39.74</b>	2.91	73.9	1.65	41.9	1-1/2"	0.62	5	20
3/4"	V6M6-B	3/4" - 14 NPTF	brass	<b>58.94</b>	2.91	73.9	1.65	41.9	1-1/2"	0.62	5	20
3/4"	V6M6-SS	3/4" - 14 NPTF	316 stainless	<b>278.02</b>	2.91	73.9	1.65	41.9	1-1/2"	0.63	5	20
1"	V8M8	1" - 11 1/2 NPTF	steel	<b>71.82</b>	3.22	81.8	2.06	52.3	1-7/8"	1.09	-	10
1"	V8M8-B	1" - 11 1/2 NPTF	brass	<b>114.65</b>	3.22	81.8	2.06	52.3	1-7/8"	1.09	-	10
1"	V8M8-SS	1" - 11 1/2 NPTF	316 stainless	<b>366.04</b>	3.22	81.8	2.06	52.3	1-7/8"	1.15	-	10
1-1/4"	V10M10	1-1/4" - 11 1/2 NPTF	steel	<b>214.58</b>	3.46	87.9	2.19	55.6	2"	1.31	-	10
1-1/4"	V10M10-B	1-1/4" - 11 1/2 NPTF	brass	<b>276.11</b>	3.46	87.9	2.19	55.6	2"	1.31	-	10
1-1/4"	V10M10-SS	1-1/4" - 11 1/2 NPTF	316 stainless	<b>671.14</b>	3.46	87.9	2.19	55.6	2"	1.35	-	10
1-1/2"	V12M12	1-1/2" - 11 1/2 NPTF	steel	<b>275.83</b>	3.85	97.8	2.74	69.6	2-1/2"	2.27	-	5
1-1/2"	V12M12-B	1-1/2" - 11 1/2 NPTF	brass	<b>378.43</b>	3.85	97.8	2.74	69.6	2-1/2"	2.27	-	5
1-1/2"	V12M12-SS	1-1/2" - 11 1/2 NPTF	316 stainless	<b>935.09</b>	3.85	97.8	2.74	69.6	2-1/2"	2.35	-	5
2"	V16M16	2" - 11 1/2 NPTF	steel	<b>507.46</b>	4.34	110.2	3.83	97.3	3-1/2"	4.77	-	5
2"	V16M16-B	2" - 11 1/2 NPTF	brass	<b>745.66</b>	4.34	110.2	3.83	97.3	3-1/2"	4.77	-	5
2"	V16M16-SS	2" - 11 1/2 NPTF	316 stainless	<b>889.29</b>	4.34	110.2	3.83	97.3	3-1/2"	4.79	-	5

## V-Series Hydraulic Couplings

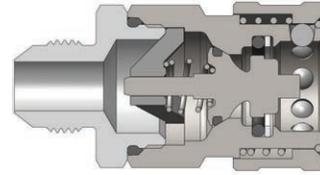

Body Size	V-Series Snap-Tite H/IH Interchange Valved Coupler (JIC Male Threads)											
	Part Detail			List Price	Length		Maximum OD		Hex Inch	Weight Lb	Package Qty	
	Part Number	Threads	Material		Inch	mm	Inch	mm			Bag	Box
1/4"	2VJM2	7/16" - 20 JIC	steel	<b>\$26.79</b>	2.12	53.8	0.99	25.1	7/8"	0.25	5	50
3/8"	3VJM3	9/16" - 18 JIC	steel	<b>41.10</b>	2.32	58.9	1.18	30.0	1"	0.30	5	50
1/2"	4VJM4	3/4" - 16 JIC	steel	<b>50.14</b>	2.54	64.5	1.36	34.5	1-3/16"	0.51	5	25
3/4"	6VJM6	1-1/16" - 12 JIC	steel	<b>72.14</b>	3.07	78.0	1.67	42.4	1-1/2"	0.98	5	20
1"	8VJM8	1-5/16" - 12 JIC	steel	<b>120.90</b>	3.32	84.3	2.06	52.3	1-7/8"	1.49	-	10
1-1/4"	10VJM10	1-5/8" - 12 JIC	steel	<b>281.24</b>	3.59	91.2	2.19	55.6	2"	1.98	-	10

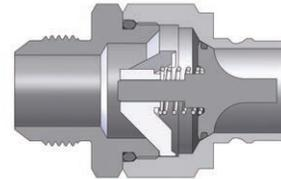

Body Size	V-Series Snap-Tite H/IH Interchange Valved Nipple (JIC Male Threads)											
	Part Detail			List Price	Length		Maximum OD		Hex Inch	Weight Lb	Package Qty	
	Part Number	Threads	Material		Inch	mm	Inch	mm			Bag	Box
1/4"	V2JM2	7/16" - 20 JIC	steel	<b>\$22.53</b>	2.06	52.3	0.97	24.6	7/8"	0.18	5	50
3/8"	V3JM3	9/16" - 18 JIC	steel	<b>28.99</b>	2.25	57.2	1.1	27.9	1"	0.25	5	50
1/2"	V4JM4	3/4" - 16 JIC	steel	<b>34.63</b>	2.40	61.0	1.31	33.3	1-3/16"	0.38	5	25
3/4"	V6JM6	1-1/16" - 12 JIC	steel	<b>46.92</b>	2.91	73.9	1.65	41.9	1-1/2"	0.72	5	20
1"	V8JM8	1-5/16" - 12 JIC	steel	<b>89.03</b>	3.22	81.8	2.06	52.3	1-7/8"	1.36	-	10
1-1/4"	V10JM10	1-5/8" - 12 JIC	steel	<b>266.24</b>	3.46	87.9	2.19	55.6	2"	1.46	-	10

## V-Series Hydraulic Couplings

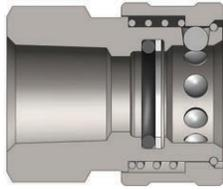

Body Size	V-Series Snap-Tite H/H Interchange Unvalved Coupler (Female Threads)											
	Part Detail			List Price	Length		Maximum OD		Hex Inch	Weight Lb	Package Qty	
	Part Number	Threads	Material		Inch	mm	Inch	mm			Bag	Box
1/4"	2VF2-E	1/4" - 18 NPTF	steel	<b>\$14.83</b>	1.36	34.5	0.99	25.1	7/8"	0.18	5	50
1/4"	2VF2-B-E	1/4" - 18 NPTF	brass	<b>17.10</b>	1.36	34.5	0.99	25.1	7/8"	0.18	5	50
1/4"	2VF2-SS-E	1/4" - 18 NPTF	316 stainless	<b>66.68</b>	1.36	34.5	0.99	25.1	7/8"	0.18	5	50
1/4"	2VBF2-E	1/4" - 19 BSPP	steel	<b>15.97</b>	1.36	34.5	0.99	25.1	7/8"	0.18	5	50
1/4"	2VBF2-B-E	1/4" - 19 BSPP	brass	<b>16.28</b>	1.36	34.5	0.99	25.1	7/8"	0.17	5	50
1/4"	2VBF2-SS-E	1/4" - 19 BSPP	316 stainless	<b>66.69</b>	1.36	34.5	0.99	25.1	7/8"	0.18	5	50
3/8"	3VF3-E	3/8" - 18 NPTF	steel	<b>21.64</b>	1.50	38.1	1.18	30.0	7/8"	0.28	5	50
3/8"	3VF3-B-E	3/8" - 18 NPTF	brass	<b>28.33</b>	1.50	38.1	1.18	30.0	7/8"	0.27	5	50
3/8"	3VF3-SS-E	3/8" - 18 NPTF	316 stainless	<b>85.35</b>	1.50	38.1	1.18	30.0	7/8"	0.29	5	50
3/8"	3VBF3-E	3/8" - 19 BSPP	steel	<b>21.64</b>	1.50	38.1	1.18	30.0	7/8"	0.27	5	50
3/8"	3VBF3-B-E	3/8" - 19 BSPP	brass	<b>28.33</b>	1.50	38.1	1.18	30.0	7/8"	0.26	5	50
3/8"	3VBF3-SS-E	3/8" - 19 BSPP	316 stainless	<b>85.35</b>	1.50	38.1	1.18	30.0	7/8"	0.29	5	50
1/2"	4VF4-E	1/2" - 14 NPTF	steel	<b>27.30</b>	1.64	41.7	1.37	34.8	1-3/16"	0.39	5	25
1/2"	4VF4-B-E	1/2" - 14 NPTF	brass	<b>33.81</b>	1.64	41.7	1.37	34.8	1-3/16"	0.39	5	25
1/2"	4VF4-SS-E	1/2" - 14 NPTF	316 stainless	<b>108.05</b>	1.64	41.7	1.37	34.8	1-3/16"	0.38	5	25
1/2"	4VBF4-E	1/2" - 14 BSPP	steel	<b>27.30</b>	1.64	41.7	1.37	34.8	1-3/16"	0.39	5	25
1/2"	4VBF4-B-E	1/2" - 14 BSPP	brass	<b>32.21</b>	1.64	41.7	1.37	34.8	1-3/16"	0.40	5	25
1/2"	4VBF4-SS-E	1/2" - 14 BSPP	316 stainless	<b>108.05</b>	1.64	41.7	1.37	34.8	1-3/16"	0.40	5	25
3/4"	6VF6-E	3/4" - 14 NPTF	steel	<b>41.83</b>	1.96	49.8	1.67	42.4	1-1/2"	0.64	5	20
3/4"	6VF6-B-E	3/4" - 14 NPTF	brass	<b>48.06</b>	1.96	49.8	1.67	42.4	1-1/2"	0.62	5	20
3/4"	6VF6-SS-E	3/4" - 14 NPTF	316 stainless	<b>172.05</b>	1.96	49.8	1.67	42.4	1-1/2"	0.61	5	20
3/4"	6VBF6-E	3/4" - 14 BSPP	steel	<b>41.83</b>	1.96	49.8	1.67	42.4	1-1/2"	0.64	5	20
3/4"	6VBF6-B-E	3/4" - 14 BSPP	brass	<b>48.05</b>	1.96	49.8	1.67	42.4	1-1/2"	0.63	5	20
3/4"	6VBF6-SS-E	3/4" - 14 BSPP	316 stainless	<b>172.05</b>	1.96	49.8	1.67	42.4	1-1/2"	0.64	5	20
1"	8VF8-E	1" - 11 1/2 NPTF	steel	<b>53.93</b>	2.10	53.3	1.99	50.5	1-13/16"	1.05	-	10
1"	8VF8-B-E	1" - 11 1/2 NPTF	brass	<b>79.05</b>	2.10	53.3	1.99	50.5	1-13/16"	1.02	-	10
1"	8VF8-SS-E	1" - 11 1/2 NPTF	316 stainless	<b>235.57</b>	2.10	53.3	1.99	50.5	1-13/16"	1.02	-	10
1"	8VBF8-E	1" - 11 BSPP	steel	<b>53.93</b>	2.10	53.3	1.99	50.5	1-13/16"	1.04	-	10
1"	8VBF8-B-E	1" - 11 BSPP	brass	<b>75.28</b>	2.10	53.3	1.99	50.5	1-13/16"	1.03	-	10
1"	8VBF8-SS-E	1" - 11 BSPP	316 stainless	<b>235.57</b>	2.10	53.3	1.99	50.5	1-13/16"	1.04	-	10
1-1/4"	10VF10-E	1-1/4" - 11 1/2 NPTF	steel	<b>109.70</b>	2.28	57.9	2.19	55.6	2"	1.08	-	10
1-1/4"	10VF10-B-E	1-1/4" - 11 1/2 NPTF	brass	<b>140.10</b>	2.28	57.9	2.19	55.6	2"	1.10	-	10
1-1/4"	10VF10-SS-E	1-1/4" - 11 1/2 NPTF	316 stainless	<b>362.31</b>	2.28	57.9	2.19	55.6	2"	1.10	-	10
1-1/4"	10VBF10-E	1-1/4" - 11 BSPP	steel	<b>109.70</b>	2.28	57.9	2.19	55.6	2"	1.10	-	10
1-1/4"	10VBF10-B-E	1-1/4" - 11 BSPP	brass	<b>140.12</b>	2.28	57.9	2.19	55.6	2"	1.09	-	10
1-1/4"	10VBF10-SS-E	1-1/4" - 11 BSPP	316 stainless	<b>383.50</b>	2.28	57.9	2.19	55.6	2"	1.10	-	10
1-1/2"	12VF12-E	1-1/2" - 11 1/2 NPTF	steel	<b>166.67</b>	2.57	65.3	2.74	69.6	2-1/2"	1.78	-	5
1-1/2"	12VF12-B-E	1-1/2" - 11 1/2 NPTF	brass	<b>308.65</b>	2.57	65.3	2.74	69.6	2-1/2"	1.78	-	5
1-1/2"	12VF12-SS-E	1-1/2" - 11 1/2 NPTF	316 stainless	<b>652.20</b>	2.57	65.3	2.74	69.6	2-1/2"	1.78	-	5
2"	16VF16-E	2" - 11 1/2 NPTF	steel	<b>258.25</b>	2.48	63.0	3.56	90.4	3-1/4"	3.12	-	5
2"	16VF16-B-E	2" - 11 1/2 NPTF	brass	<b>715.60</b>	2.48	63.0	3.56	90.4	3-1/4"	3.13	-	5
2"	16VF16-SS-E	2" - 11 1/2 NPTF	316 stainless	<b>790.50</b>	2.48	63.0	3.56	90.4	3-1/4"	3.13	-	5

## V-Series Hydraulic Couplings

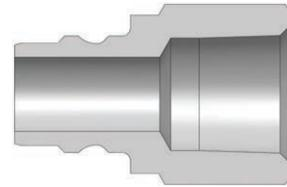

Body Size	V-Series Snap-Tite H/H Interchange Unvalved Nipple (Female Threads)											
	Part Detail			List Price	Length		Maximum OD		Hex Inch	Weight Lb	Package Qty	
	Part Number	Threads	Material		Inch	mm	Inch	mm			Bag	Box
1/4"	V2F2-E	1/4" - 18 NPTF	steel	<b>\$7.33</b>	1.27	32.3	0.69	17.5	5/8"	0.05	5	50
1/4"	V2F2-B-E	1/4" - 18 NPTF	brass	<b>8.02</b>	1.27	32.3	0.69	17.5	5/8"	0.06	5	50
1/4"	V2F2-SS-E	1/4" - 18 NPTF	316 stainless	<b>23.75</b>	1.27	32.3	0.69	17.5	5/8"	0.06	5	50
1/4"	V2BF2-E	1/4" - 19 BSPP	steel	<b>7.33</b>	1.27	32.3	0.69	17.5	5/8"	0.06	5	50
1/4"	V2BF2-B-E	1/4" - 19 BSPP	brass	<b>8.01</b>	1.27	32.3	0.69	17.5	5/8"	0.06	5	50
1/4"	V2BF2-SS-E	1/4" - 19 BSPP	316 stainless	<b>23.75</b>	1.27	32.3	0.69	17.5	5/8"	0.05	5	50
3/8"	V3F3-E	3/8" - 18 NPTF	steel	<b>8.18</b>	1.41	35.8	0.90	22.9	13/16"	0.08	5	50
3/8"	V3F3-B-E	3/8" - 18 NPTF	brass	<b>9.81</b>	1.41	35.8	0.90	22.9	13/16"	0.08	5	50
3/8"	V3F3-SS-E	3/8" - 18 NPTF	316 stainless	<b>34.52</b>	1.41	35.8	0.90	22.9	13/16"	0.08	5	50
3/8"	V3BF3-E	3/8" - 19 BSPP	steel	<b>8.17</b>	1.41	35.8	0.90	22.9	13/16"	0.07	5	50
3/8"	V3BF3-B-E	3/8" - 19 BSPP	brass	<b>9.81</b>	1.41	35.8	0.90	22.9	13/16"	0.08	5	50
3/8"	V3BF3-SS-E	3/8" - 19 BSPP	316 stainless	<b>34.52</b>	1.41	35.8	0.90	22.9	13/16"	0.07	5	50
1/2"	V4F4-E	1/2" - 14 NPTF	steel	<b>10.20</b>	1.72	43.7	1.10	27.9	1"	0.18	5	25
1/2"	V4F4-B-E	1/2" - 14 NPTF	brass	<b>11.93</b>	1.72	43.7	1.10	27.9	1"	0.18	5	25
1/2"	V4F4-SS-E	1/2" - 14 NPTF	316 stainless	<b>43.07</b>	1.72	43.7	1.10	27.9	1"	0.18	5	25
1/2"	V4BF4-E	1/2" - 14 BSPP	steel	<b>10.20</b>	1.72	43.7	1.10	27.9	1"	0.17	5	25
1/2"	V4BF4-B-E	1/2" - 14 BSPP	brass	<b>11.93</b>	1.72	43.7	1.10	27.9	1"	0.17	5	25
1/2"	V4BF4-SS-E	1/2" - 14 BSPP	316 stainless	<b>43.07</b>	1.72	43.7	1.10	27.9	1"	0.16	5	25
3/4"	V6F6-E	3/4" - 14 NPTF	steel	<b>14.51</b>	1.86	47.2	1.31	33.3	1-3/16"	0.22	5	20
3/4"	V6F6-B-E	3/4" - 14 NPTF	brass	<b>20.84</b>	1.86	47.2	1.31	33.3	1-3/16"	0.22	5	20
3/4"	V6F6-SS-E	3/4" - 14 NPTF	316 stainless	<b>60.85</b>	1.86	47.2	1.31	33.3	1-3/16"	0.22	5	20
3/4"	V6BF6-E	3/4" - 14 BSPP	steel	<b>14.51</b>	1.86	47.2	1.31	33.3	1-3/16"	0.23	5	20
3/4"	V6BF6-B-E	3/4" - 14 BSPP	brass	<b>20.84</b>	1.86	47.2	1.31	33.3	1-3/16"	0.22	5	20
3/4"	V6BF6-SS-E	3/4" - 14 BSPP	316 stainless	<b>60.85</b>	1.86	47.2	1.31	33.3	1-3/16"	0.22	5	20
1"	V8F8-E	1" - 11 1/2 NPTF	steel	<b>25.94</b>	2.08	52.8	1.65	41.9	1-1/2"	0.38	-	10
1"	V8F8-B-E	1" - 11 1/2 NPTF	brass	<b>27.06</b>	2.08	52.8	1.65	41.9	1-1/2"	0.38	-	10
1"	V8F8-SS-E	1" - 11 1/2 NPTF	316 stainless	<b>116.37</b>	2.08	52.8	1.65	41.9	1-1/2"	0.38	-	10
1"	V8BF8-E	1" - 11 BSPP	steel	<b>25.93</b>	2.08	52.8	1.65	41.9	1-1/2"	0.38	-	10
1"	V8BF8-B-E	1" - 11 BSPP	brass	<b>27.06</b>	2.08	52.8	1.65	41.9	1-1/2"	0.38	-	10
1"	V8BF8-SS-E	1" - 11 BSPP	316 stainless	<b>116.37</b>	2.08	52.8	1.65	41.9	1-1/2"	0.38	-	10
1-1/4"	V10F10-E	1-1/4" - 11 1/2 NPTF	steel	<b>50.63</b>	2.22	56.4	2.06	52.3	1-7/8"	0.57	-	10
1-1/4"	V10F10-B-E	1-1/4" - 11 1/2 NPTF	brass	<b>49.69</b>	2.22	56.4	2.06	52.3	1-7/8"	0.56	-	10
1-1/4"	V10F10-SS-E	1-1/4" - 11 1/2 NPTF	316 stainless	<b>205.12</b>	2.22	56.4	2.06	52.3	1-7/8"	0.56	-	10
1-1/4"	V10BF10-E	1-1/4" - 11 BSPP	steel	<b>50.63</b>	2.22	56.4	2.06	52.3	1-7/8"	0.57	-	10
1-1/4"	V10BF10-B-E	1-1/4" - 11 BSPP	brass	<b>49.68</b>	2.22	56.4	2.06	52.3	1-7/8"	0.55	-	10
1-1/4"	V10BF10-SS-E	1-1/4" - 11 BSPP	316 stainless	<b>205.12</b>	2.22	56.4	2.06	52.3	1-7/8"	0.55	-	10
1-1/2"	V12F12-E	1-1/2" - 11 1/2 NPTF	steel	<b>86.49</b>	2.44	62.0	2.33	59.2	2-1/8"	0.84	-	5
1-1/2"	V12F12-B-E	1-1/2" - 11 1/2 NPTF	brass	<b>137.76</b>	2.44	62.0	2.33	59.2	2-1/8"	0.84	-	5
1-1/2"	V12F12-SS-E	1-1/2" - 11 1/2 NPTF	316 stainless	<b>295.66</b>	2.44	62.0	2.33	59.2	2-1/8"	0.83	-	5
2"	V16F16-E	2" - 11 1/2 NPTF	steel	<b>114.28</b>	2.60	66.0	3.01	76.5	2-3/4"	1.34	-	5
2"	V16F16-B-E	2" - 11 1/2 NPTF	brass	<b>169.26</b>	2.60	66.0	3.01	76.5	2-3/4"	1.34	-	5
2"	V16F16-SS-E	2" - 11 1/2 NPTF	316 stainless	<b>408.51</b>	2.60	66.0	3.01	76.5	2-3/4"	1.35	-	5



## V-Series Hydraulic Couplings

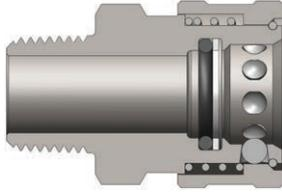

Body Size	V-Series Snap-Tite H/IH Interchange Unvalved Coupler (Male Threads)											
	Part Detail			List Price	Length		Maximum OD		Hex Inch	Weight Lb	Package Qty	
	Part Number	Threads	Material		Inch	mm	Inch	mm			Bag	Box
1/4"	2VM2-E	1/4" - 18 NPTF	steel	<b>\$16.76</b>	1.82	46.2	0.99	25.1	5/8"	0.19	5	50
1/4"	2VM2-B-E	1/4" - 18 NPTF	brass	<b>17.10</b>	1.82	46.2	0.99	25.1	5/8"	0.19	5	50
1/4"	2VM2-SS-E	1/4" - 18 NPTF	316 stainless	<b>74.08</b>	1.82	46.2	0.99	25.1	5/8"	0.19	5	50
3/8"	3VM3-E	3/8" - 18 NPTF	steel	<b>24.46</b>	1.76	44.7	1.18	30.0	13-16"	0.28	5	50
3/8"	3VM3-B-E	3/8" - 18 NPTF	brass	<b>28.33</b>	1.76	44.7	1.18	30.0	13/16"	0.28	5	50
3/8"	3VM3-SS-E	3/8" - 18 NPTF	316 stainless	<b>94.89</b>	1.76	44.7	1.18	30.0	13/16"	0.29	5	50
1/2"	4VM4-E	1/2" - 14 NPTF	steel	<b>30.80</b>	2.03	51.6	1.37	34.8	1"	0.38	5	25
1/2"	4VM4-B-E	1/2" - 14 NPTF	brass	<b>33.81</b>	2.03	51.6	1.37	34.8	1"	0.36	5	25
1/2"	4VM4-SS-E	1/2" - 14 NPTF	316 stainless	<b>120.06</b>	2.03	51.6	1.37	34.8	1"	0.38	5	25
3/4"	6VM6-E	3/4" - 14 NPTF	steel	<b>47.15</b>	2.29	58.2	1.67	42.4	1-3/16"	0.62	5	20
3/4"	6VM6-B-E	3/4" - 14 NPTF	brass	<b>48.05</b>	2.29	58.2	1.67	42.4	1-3/16"	0.62	5	20
3/4"	6VM6-SS-E	3/4" - 14 NPTF	316 stainless	<b>191.25</b>	2.29	58.2	1.67	42.4	1-3/16"	0.60	5	20
1"	8VM8-E	1" - 11 1/2 NPTF	steel	<b>60.82</b>	2.39	60.7	1.99	50.5	1-1/2"	0.88	-	10
1"	8VM8-B-E	1" - 11 1/2 NPTF	brass	<b>79.05</b>	2.39	60.7	1.99	50.5	1-1/2"	0.90	-	10
1"	8VM8-SS-E	1" - 11 1/2 NPTF	316 stainless	<b>261.81</b>	2.39	60.7	1.99	50.5	1-1/2"	0.89	-	10
1-1/4"	10VM10-E	1-1/4" - 11 1/2 NPTF	steel	<b>123.71</b>	2.78	70.6	2.19	55.6	1-7/8"	1.20	-	10
1-1/4"	10VM10-SS-E	1-1/4" - 11 1/2 NPTF	316 stainless	<b>402.69</b>	2.78	70.6	2.19	55.6	1-7/8"	1.20	-	10
1-1/2"	12VM12-E	1-1/2" - 11 1/2 NPTF	steel	<b>187.95</b>	3.08	78.2	2.74	69.6	2-1/8"	2.08	-	5
1-1/2"	12VM12-SS-E	1-1/2" - 11 1/2 NPTF	316 stainless	<b>793.92</b>	3.08	78.2	2.74	69.6	2-1/8"	2.08	-	5
2"	16VM16-E	2" - 11 1/2 NPTF	steel	<b>319.02</b>	3.10	78.7	3.56	90.4	2-1/2"	3.73	-	5
2"	16VM16-SS-E	2" - 11 1/2 NPTF	316 stainless	<b>878.56</b>	3.10	78.7	3.56	90.4	2-1/2"	3.73	-	5

## V-Series Hydraulic Couplings

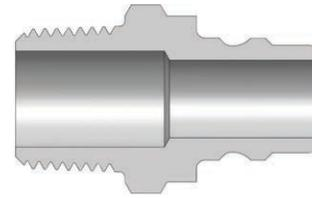

Body Size	V-Series Snap-Tite H/IH Interchange Unvalved Nipple (Male Threads)											
	Part Detail			List Price	Length		Maximum OD		Hex Inch	Weight Lb	Package Qty	
	Part Number	Threads	Material		Inch	mm	Inch	mm			Bag	Box
1/4"	V2M2-E	1/4" - 18 NPTF	steel	<b>\$7.33</b>	1.52	38.6	0.69	17.5	5/8"	0.16	5	50
1/4"	V2M2-B-E	1/4" - 18 NPTF	brass	<b>8.02</b>	1.52	38.6	0.69	17.5	5/8"	0.16	5	50
1/4"	V2M2-SS-E	1/4" - 18 NPTF	316 stainless	<b>23.75</b>	1.52	38.6	0.69	17.5	5/8"	0.16	5	50
3/8"	V3M3-E	3/8" - 18 NPTF	steel	<b>8.18</b>	1.72	43.7	0.90	22.9	13-16"	0.11	5	50
3/8"	V3M3-B-E	3/8" - 18 NPTF	brass	<b>9.81</b>	1.72	43.7	0.90	22.9	13/16"	0.11	5	50
3/8"	V3M3-SS-E	3/8" - 18 NPTF	316 stainless	<b>34.52</b>	1.72	43.7	0.90	22.9	13/16"	0.11	5	50
1/2"	V4M4-E	1/2" - 14 NPTF	steel	<b>9.72</b>	1.80	45.7	1.10	27.9	1"	0.15	5	25
1/2"	V4M4-B-E	1/2" - 14 NPTF	brass	<b>11.93</b>	1.80	45.7	1.10	27.9	1"	0.15	5	25
1/2"	V4M4-SS-E	1/2" - 14 NPTF	316 stainless	<b>43.07</b>	1.80	45.7	1.10	27.9	1"	0.15	5	25
3/4"	V6M6-E	3/4" - 14 NPTF	steel	<b>14.51</b>	2.19	55.6	1.31	33.3	1-3/16"	0.30	5	20
3/4"	V6M6-B-E	3/4" - 14 NPTF	brass	<b>24.04</b>	2.19	55.6	1.31	33.3	1-3/16"	0.28	5	20
3/4"	V6M6-SS-E	3/4" - 14 NPTF	316 stainless	<b>90.14</b>	2.19	55.6	1.31	33.3	1-3/16"	0.28	5	20
1"	V8M8-E	1" - 11 1/2 NPTF	steel	<b>29.88</b>	2.31	58.7	1.65	41.9	1-1/2"	0.40	-	10
1"	V8M8-B-E	1" - 11 1/2 NPTF	brass	<b>36.51</b>	2.31	58.7	1.65	41.9	1-1/2"	0.40	-	10
1"	V8M8-SS-E	1" - 11 1/2 NPTF	316 stainless	<b>142.99</b>	2.31	58.7	1.65	41.9	1-1/2"	0.40	-	10
1-1/4"	V10M10-E	1-1/4" - 11 1/2 NPTF	steel	<b>64.11</b>	2.14	54.4	2.06	52.3	1-7/8"	0.83	-	10
1-1/4"	V10M10-SS-E	1-1/4" - 11 1/2 NPTF	316 stainless	<b>227.97</b>	2.14	54.4	2.06	52.3	1-7/8"	0.83	-	10
1-1/2"	V12M12-E	1-1/2" - 11 1/2 NPTF	steel	<b>100.06</b>	2.34	59.4	2.33	59.2	2-1/8"	1.08	-	5
1-1/2"	V12M12-SS-E	1-1/2" - 11 1/2 NPTF	316 stainless	<b>328.62</b>	2.34	59.4	2.33	59.2	2-1/8"	1.07	-	5
2"	V16M16-E	2" - 11 1/2 NPTF	steel	<b>160.60</b>	3.06	77.7	2.74	69.6	2-1/2"	1.44	-	5
2"	V16M16-SS-E	2" - 11 1/2 NPTF	316 stainless	<b>454.03</b>	3.06	77.7	2.74	69.6	2-1/2"	1.44	-	5



Body Size	V-Series Dust Caps and Dust Plugs					
	Part Detail			List Price	Package Qty	
	Coupler Dust Plug	Nipple Dust Cap	Material		Bag	Box
1/4"	1HDP	V2DC	Nitrile	<b>\$3.16</b>	10	50
3/8"	3VDP-V3DC	Combo dust cap/plug	Nitrile	<b>3.51</b>	10	50
1/2"	3KDP-K3DC	Combo dust cap/plug	Nitrile	<b>3.51</b>	10	50
3/4"	6VDP-V6DC	Combo dust cap/plug	Nitrile	<b>8.52</b>	5	25
1"	8VDP-V8DC	Combo dust cap/plug	Nitrile	<b>10.53</b>	5	25

## V-Series Hydraulic Couplings

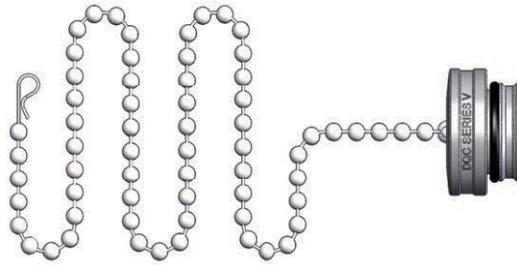

Body Size	V-Series Coupler Rigid Dust Plug						
	Part Detail			List Price	Weight Lb	Package Qty	
	Part Number	Lanyard	Body			Bag	Box
1/4"	2VDP-A	SS Bead Chain	aluminum	<b>\$10.12</b>	0.02	5	50
3/8"	3VDP-A	SS Bead Chain	aluminum	<b>10.88</b>	0.02	5	50
1/2"	4VDP-A	SS Bead Chain	aluminum	<b>11.56</b>	0.03	5	25
3/4"	6VDP-A	SS Bead Chain	aluminum	<b>15.60</b>	0.09	5	20
1"	8VDP-A	SS Bead Chain	aluminum	<b>17.38</b>	0.14	-	10
1-1/4"	10VDP-A	SS Bead Chain	aluminum	<b>25.81</b>	0.29	-	10
1-1/2"	12VDP-A	SS Bead Chain	aluminum	<b>52.80</b>	0.31	-	10
2"	16VDP-A	SS Bead Chain	aluminum	<b>90.07</b>	0.49	-	10

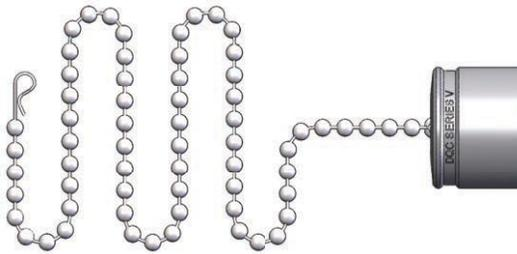

Body Size	V-Series Nipple Rigid Dust Cap						
	Part Detail			List Price	Weight Lb	Package Qty	
	Part Number	Lanyard	Body			Bag	Box
1/4"	V2DC-A	SS Bead Chain	aluminum	<b>\$10.12</b>	0.03	5	50
3/8"	V3DC-A	SS Bead Chain	aluminum	<b>10.71</b>	0.07	5	50
1/2"	V4DC-A	SS Bead Chain	aluminum	<b>14.77</b>	0.13	5	25
3/4"	V6DC-A	SS Bead Chain	aluminum	<b>18.55</b>	0.19	5	20
1"	V8DC-A	SS Bead Chain	aluminum	<b>25.31</b>	0.26	-	10
1-1/4"	V10DC-A	SS Bead Chain	aluminum	<b>32.05</b>	0.25	-	10
1-1/2"	V12DC-A	SS Bead Chain	aluminum	<b>61.57</b>	0.37	-	10
2"	V16DC-A	SS Bead Chain	aluminum	<b>77.44</b>	0.52	-	10

## V-Series Hydraulic Couplings

Body Size	V-Series Snap-Tite H/IH Interchange Coupler Seal Kits						
	Part Detail			List Price	Seal Kit Contents	Package Qty	
	Part Number	Coupler Style	Seal Material			Bag	Box
1/4"	2V-SKIT	all	Nitrile	<b>\$5.05</b>	Body/Adapter O-Rings and PTFE Back-up	25	200
1/4"	F-2V-SKIT	all	FKM	<b>7.36</b>	Body/Adapter O-Rings and PTFE Back-up	25	200
1/4"	P-2V-SKIT	all	EPDM	<b>3.47</b>	Body/Adapter O-Rings and PTFE Back-up	25	200
3/8"	3V-SKIT	all	Nitrile	<b>5.30</b>	Body/Adapter O-Rings and PTFE Back-up	25	200
3/8"	F-3V-SKIT	all	FKM	<b>7.83</b>	Body/Adapter O-Rings and PTFE Back-up	25	200
3/8"	P-3V-SKIT	all	EPDM	<b>6.88</b>	Body/Adapter O-Rings and PTFE Back-up	25	200
1/2"	4V-SKIT	all	Nitrile	<b>6.21</b>	Body/Adapter O-Rings and PTFE Back-up	25	200
1/2"	F-4V-SKIT	all	FKM	<b>8.99</b>	Body/Adapter O-Rings and PTFE Back-up	25	200
1/2"	P-4V-SKIT	all	EPDM	<b>7.36</b>	Body/Adapter O-Rings and PTFE Back-up	25	200
3/4"	6V-SKIT	all	Nitrile	<b>8.52</b>	Body/Adapter O-Rings and PTFE Back-up	25	200
3/4"	F-6V-SKIT	all	FKM	<b>11.51</b>	Body/Adapter O-Rings and PTFE Back-up	25	200
3/4"	P-6V-SKIT	all	EPDM	<b>8.52</b>	Body/Adapter O-Rings and PTFE Back-up	25	200
1"	8V-SKIT	all	Nitrile	<b>10.84</b>	Body/Adapter O-Rings and PTFE Back-up	25	200
1"	F-8V-SKIT	all	FKM	<b>14.06</b>	Body/Adapter O-Rings and PTFE Back-up	25	200
1"	P-8V-SKIT	all	EPDM	<b>11.05</b>	Body/Adapter O-Rings and PTFE Back-up	25	200
1-1/4"	10V-SKIT	all	Nitrile	<b>13.01</b>	Body/Adapter/Valve O-Rings and Back-up	10	50
1-1/4"	F-10V-SKIT	all	FKM	<b>16.83</b>	Body/Adapter/Valve O-Rings and Back-up	10	50
1-1/4"	P-10V-SKIT	all	EPDM	<b>13.55</b>	Body/Adapter/Valve O-Rings and Back-up	10	50
1-1/2"	12V-SKIT	all	Nitrile	<b>15.59</b>	Body/Adapter/Valve O-Rings and Back-up	10	50
1-1/2"	F-12V-SKIT	all	FKM	<b>20.20</b>	Body/Adapter/Valve O-Rings and Back-up	10	50
1-1/2"	P-12V-SKIT	all	EPDM	<b>16.58</b>	Body/Adapter/Valve O-Rings and Back-up	10	50
2"	16V-SKIT	all	Nitrile	<b>16.72</b>	Body/Adapter/Valve O-Rings and Back-up	10	50
2"	F-16V-SKIT	all	FKM	<b>21.27</b>	Body/Adapter/Valve O-Rings and Back-up	10	50
2"	P-16V-SKIT	all	EPDM	<b>19.37</b>	Body/Adapter/Valve O-Rings and Back-up	10	50

## V-Series Hydraulic Couplings

V-Series Snap-Tite H/IH Interchange Coupler Repair Kits							
Body Size	Part Detail			List Price	Repair Kit Contents (for one coupler)	Package Qty	
	Part Number	Coupler Material	Seal Material			Bag	Box
1/4"	2V-RKIT	steel	Nitrile	<b>\$5.91</b>	Steel Valve Assembly and Adapter O-Ring	1	25
1/4"	2V-BRKIT	brass	Nitrile	<b>7.00</b>	Brass Valve Assembly and Adapter O-Ring	1	25
1/4"	2V-SSRKIT	316 stainless	Nitrile	<b>14.85</b>	316 SS Valve Assembly and Adapter O-Ring	1	25
3/8"	3V-RKIT	steel	Nitrile	<b>7.85</b>	Steel Valve Assembly and Adapter O-Ring	1	25
3/8"	3V-BRKIT	brass	Nitrile	<b>8.87</b>	Brass Valve Assembly and Adapter O-Ring	1	25
3/8"	3V-SSRKIT	316 stainless	Nitrile	<b>18.50</b>	316 SS Valve Assembly and Adapter O-Ring	1	25
1/2"	4V-RKIT	steel	Nitrile	<b>13.32</b>	Steel Valve Assembly and Adapter O-Ring	1	25
1/2"	4V-BRKIT	brass	Nitrile	<b>17.73</b>	Brass Valve Assembly and Adapter O-Ring	1	25
1/2"	4V-SSRKIT	316 stainless	Nitrile	<b>42.80</b>	316 SS Valve Assembly and Adapter O-Ring	1	25
3/4"	6V-RKIT	steel	Nitrile	<b>19.94</b>	Steel Valve Assembly and Adapter O-Ring	1	25
3/4"	6V-BRKIT	brass	Nitrile	<b>31.35</b>	Brass Valve Assembly and Adapter O-Ring	1	25
3/4"	6V-SSRKIT	316 stainless	Nitrile	<b>75.66</b>	316 SS Valve Assembly and Adapter O-Ring	1	25
1"	8V-RKIT	steel	Nitrile	<b>33.25</b>	Steel Valve Assembly and Adapter O-Ring	1	25
1"	8V-BRKIT	brass	Nitrile	<b>49.76</b>	Brass Valve Assembly and Adapter O-Ring	1	25
1"	8V-SSRKIT	316 stainless	Nitrile	<b>120.13</b>	316 SS Valve Assembly and Adapter O-Ring	1	25
1-1/4"	140030-10	steel	Nitrile	<b>34.71</b>	Steel Valve Assembly and Adapter O-Ring	1	25
1-1/4"	140032-10	316 stainless	Nitrile	<b>109.32</b>	316 SS Valve Assembly and Adapter O-Ring	1	25
1-1/2"	140030-12	steel	Nitrile	<b>43.37</b>	Steel Valve Assembly and Adapter O-Ring	1	25
1-1/2"	140032-12	316 stainless	Nitrile	<b>120.78</b>	316 SS Valve Assembly and Adapter O-Ring	1	25
2"	140030-16	steel	Nitrile	<b>54.24</b>	Steel Valve Assembly and Adapter O-Ring	1	25
2"	140032-16	316 stainless	Nitrile	<b>150.99</b>	316 SS Valve Assembly and Adapter O-Ring	1	25

V-Series Snap-Tite H/IH Interchange Nipple Repair Kits							
Body Size	Part Detail			List Price	Repair Kit Contents (for one nipple)	Package Qty	
	Part Number	Coupler Material	Seal Material			Bag	Box
1/4"	V2-RKIT	steel	Nitrile	<b>\$5.91</b>	Steel Valve Assembly and Adapter O-Ring	1	25
1/4"	V2-BRKIT	brass	Nitrile	<b>7.00</b>	Brass Valve Assembly and Adapter O-Ring	1	25
1/4"	V2-SSRKIT	316 stainless	Nitrile	<b>14.85</b>	316 SS Valve Assembly and Adapter O-Ring	1	25
3/8"	V3-RKIT	steel	Nitrile	<b>7.85</b>	Steel Valve Assembly and Adapter O-Ring	1	25
3/8"	V3-BRKIT	brass	Nitrile	<b>9.14</b>	Brass Valve Assembly and Adapter O-Ring	1	25
3/8"	V3-SSRKIT	316 stainless	Nitrile	<b>18.50</b>	316 SS Valve Assembly and Adapter O-Ring	1	25
1/2"	V4-RKIT	steel	Nitrile	<b>12.77</b>	Steel Valve Assembly and Adapter O-Ring	1	25
1/2"	V4-BRKIT	brass	Nitrile	<b>17.53</b>	Brass Valve Assembly and Adapter O-Ring	1	25
1/2"	V4-SSRKIT	316 stainless	Nitrile	<b>40.39</b>	316 SS Valve Assembly and Adapter O-Ring	1	25
3/4"	V6-RKIT	steel	Nitrile	<b>19.70</b>	Steel Valve Assembly and Adapter O-Ring	1	25
3/4"	V6-BRKIT	brass	Nitrile	<b>30.32</b>	Brass Valve Assembly and Adapter O-Ring	1	25
3/4"	V6-SSRKIT	316 stainless	Nitrile	<b>73.24</b>	316 SS Valve Assembly and Adapter O-Ring	1	25
1"	V8-RKIT	steel	Nitrile	<b>28.87</b>	Steel Valve Assembly and Adapter O-Ring	1	25
1"	V8-BRKIT	brass	Nitrile	<b>37.13</b>	Brass Valve Assembly and Adapter O-Ring	1	25
1"	V8-SSRKIT	316 stainless	Nitrile	<b>89.67</b>	316 SS Valve Assembly and Adapter O-Ring	1	25
1-1/4"	140030-10	steel	Nitrile	<b>34.71</b>	Steel Valve Assembly and Adapter O-Ring	1	25
1-1/4"	140032-10	316 stainless	Nitrile	<b>109.32</b>	316 SS Valve Assembly and Adapter O-Ring	1	25
1-1/2"	140030-12	steel	Nitrile	<b>43.37</b>	Steel Valve Assembly and Adapter O-Ring	1	25
1-1/2"	140032-12	316 stainless	Nitrile	<b>120.78</b>	316 SS Valve Assembly and Adapter O-Ring	1	25
2"	140030-16	steel	Nitrile	<b>54.24</b>	Steel Valve Assembly and Adapter O-Ring	1	25
2"	140032-16	316 stainless	Nitrile	<b>150.99</b>	316 SS Valve Assembly and Adapter O-Ring	1	25

# TR-Series Hydraulic Couplings

## Interchange Data:

- TEMA European Interchange
- TEMA 3800, 5000, 7500, 10000 Series
- CEJN Series 525

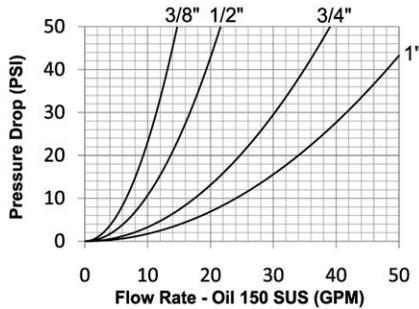

## Materials:

- Machined components are manufactured using solid steel bar stock.
- Stainless steel balls, retaining rings, and springs maximize corrosion resistance and extend service life.
- Steel componentry is plated using ROHS Compliant Trivalent Chrome.
- Steel coupler sleeves are hardened to resist deformation and maximize service life.
- Steel nipples are hardened to provide heavy duty performance.

## Seal Components:

- Nitrile (Buna-N) seals are standard, providing a temperature range of -40°F to +250°F (-40°C to +121°C).
- Couplers have a redundant O-Ring sealing system (dual O-Rings with inner PTFE back-up ring).
- Valve seals are crimped in place to maintain integrity during excessive flow conditions and pressurized connection.

## Rated Pressure Chart:

Body Size	R-Series TEMA European Interchange (Connected)			
	Steel Coupler/Plug			
	Maximum Working		Burst	
	PSI	Bar	PSI	Bar
3/8"	5,000	345	20,000	1,400
1/2"	4,000	275	16,500	1,100
3/4"	4,000	275	15,400	1,000
1"	3,200	220	12,800	900

## Technical Specifications:

Body Size	Interchange Standards				Functional Parameters				
	U.S. Military	U.S. Government	International Standards	ANSI/NFPA Standards	Locking Ball Quantity	Air Inclusion	Fluid Loss	Vacuum Inch HG	Flow $\Delta P = 22$ PSI
3/8"	-	-	-	-	9	2.8cc	1.9cc	28	10 GPM
1/2"	-	-	-	-	9	3.9cc	3.1cc	28	15 GPM
3/4"	-	-	-	-	9	10.5cc	10.1cc	28	26 GPM
1"	-	-	-	-	9	14.7cc	14.2cc	28	36 GPM

## TR Interchange Profiles

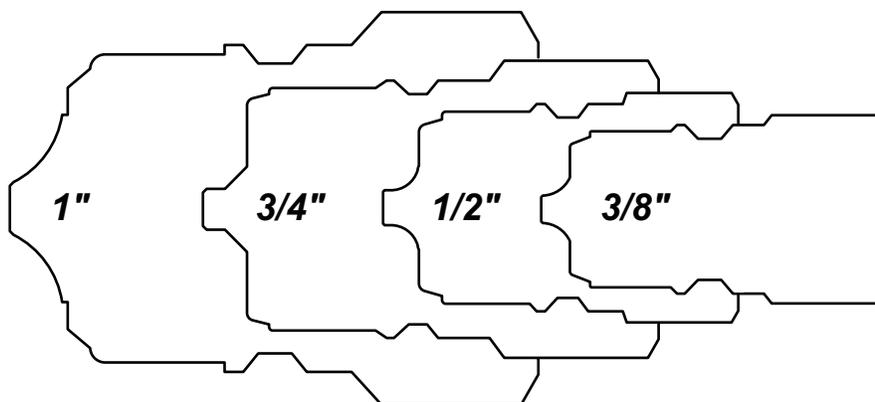

## TR-Series Hydraulic Couplings

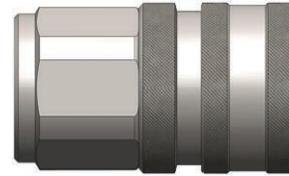
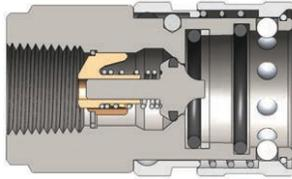

Body Size	TR-Series TEMA European Interchange Coupler (Female Threads)											
	Part Detail			List Price	Length		Maximum OD		Hex mm	Weight Lb	Package Qty	
	Part Number	Threads	Material		Inch	mm	Inch	mm			Bag	Box
3/8"	3TRF3	3/8" - 18 NPTF	steel	<b>\$85.23</b>	2.52	64.0	1.38	35.0	30	0.51	10	50
3/8"	3TRBF3	3/8" - 19 BSPP	steel	<b>85.23</b>	2.52	64.0	1.38	35.0	30	0.51	10	50
1/2"	4TRF4	1/2" - 14 NPTF	steel	<b>101.21</b>	2.62	66.5	1.57	40.0	36	0.80	5	25
1/2"	4TRBF4	1/2" - 14 BSPP	steel	<b>101.21</b>	2.62	66.5	1.57	40.0	36	0.80	5	25
3/4"	6TRF6	3/4" - 14 NPTF	steel	<b>129.99</b>	3.35	85.0	2.05	52.0	41	1.40	-	10
3/4"	6TRBF6	3/4" - 14 BSPP	steel	<b>129.99</b>	3.35	85.0	2.05	52.0	41	1.40	-	10
1"	8TRF8	1" - 11 1/2 NPTF	steel	<b>196.76</b>	3.90	99.0	2.56	65.0	55	1.95	-	10
1"	8TRBF8	1" - 11 BSPP	steel	<b>196.76</b>	3.90	99.0	2.56	65.0	55	1.95	-	10

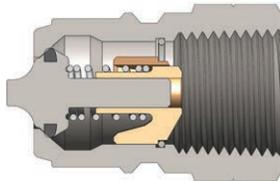

Body Size	TR-Series TEMA European Interchange Nipple (Female Threads)											
	Part Detail			List Price	Length		Maximum OD		Hex mm	Weight Lb	Package Qty	
	Part Number	Threads	Material		Inch	mm	Inch	mm			Bag	Box
3/8"	TR3F3	3/8" - 18 NPTF	steel	<b>\$31.00</b>	1.59	40.5	1.00	25.4	22	0.16	10	50
3/8"	TR3BF3	3/8" - 19 BSPP	steel	<b>31.00</b>	1.59	40.5	1.00	25.4	22	0.16	10	50
1/2"	TR4F4	1/2" - 14 NPTF	steel	<b>35.74</b>	1.63	41.5	1.23	31.1	27	0.26	5	25
1/2"	TR4BF4	1/2" - 14 BSPP	steel	<b>35.74</b>	1.63	41.5	1.23	31.1	27	0.26	5	25
3/4"	TR6F6	3/4" - 14 NPTF	steel	<b>56.93</b>	2.20	56.0	1.63	41.5	36	0.46	-	10
3/4"	TR6BF6	3/4" - 14 BSPP	steel	<b>56.93</b>	2.20	56.0	1.63	41.5	36	0.46	-	10
1"	TR8F8	1" - 11 1/2 NPTF	steel	<b>84.16</b>	2.48	63.0	2.09	53.0	46	0.80	-	10
1"	TR8BF8	1" - 11 BSPP	steel	<b>84.16</b>	2.48	63.0	2.09	53.0	46	0.80	-	10

Body Size	TR-Series TEMA European Coupler Seal Kits						
	Part Detail			List Price	Seal Kit Contents	Package Qty	
	Part Number	Coupler Style	Seal Material			Bag	Box
3/8"	3TR-SKIT	all	Nitrile	<b>\$4.88</b>	Two O-Rings and One PTFE Back-Up Ring	25	200
1/2"	4TR-SKIT	all	Nitrile	<b>5.67</b>	Two O-Rings and One PTFE Back-Up Ring	25	200
3/4"	6TR-SKIT	all	Nitrile	<b>7.51</b>	Two O-Rings and One PTFE Back-Up Ring	25	200
1"	8TR-SKIT	all	Nitrile	<b>9.98</b>	Two O-Rings and One PTFE Back-Up Ring	25	200

Please contact the factory for dust caps and dust plugs

# HT-Series Hydraulic Couplings

## Interchange Data:

- Interchangeable to ISO16028
- Parker FEM-Series, Snap-Tite 74-Series, Hansen FF, Aeroquip/Eaton FD89, Stucchi FIRG/Series 'A', FASTER FFN/FFI/2FFN/2FFI, Safeway FF49-Series

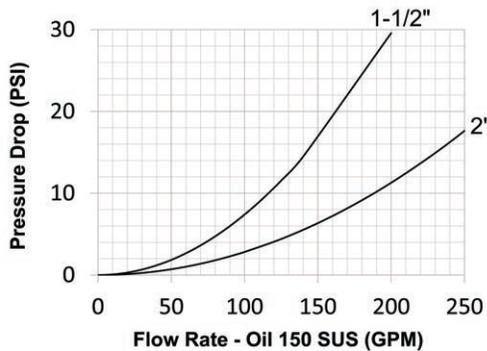
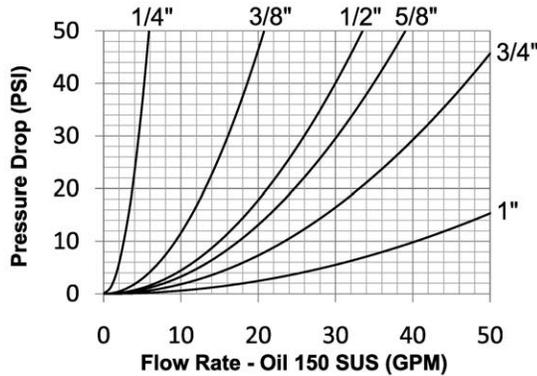

## Materials:

- Machined components are manufactured using solid steel or 316 stainless steel bar stock.
- Stainless steel balls, retaining rings, and springs maximize corrosion resistance and extend service life.
- Steel componentry is plated using ROHS Compliant Zinc Nickel for superior corrosion resistance.
- Steel coupler sleeves are hardened to resist deformation and maximize service life.
- Steel nipples are hardened to provide resistance to brinelling during impulse service.

## Seal Components:

- 3/8", 1/2", and 3/4" nipples have molded Polyurethane valve seals, with a temperature range of -65°F to +212°F (-54°C to +100°C).
- 1/4", 5/8" and 1" to 2" nipples have Nitrile-Energized PTFE valve seals, with a temperature range of -40°F to +250°F (-40°C to +121°C).
- Couplers have a polyurethane valve stem O-Ring, with a temperature range of -65°F to +212°F (-54°C to +100°C).
- Ancillary coupler and nipple seals are Nitrile (Buna-N), temperature range of -40°F to +250°F (-40°C to +121°C).
- PTFE or TPC-ET Anti-Extrusion ring protects main coupling valve seal from dynamic impulse pressure damage.

## Rated Pressure Chart:

Body Size	HT-Series ISO16028 Flushface															
	Steel Coupler/Plug Coupled				316SS Coupler/Plug Coupled				Steel Coupler Uncoupled				Steel Plug Uncoupled			
	Max. Working		Burst		Max. Working		Burst		Max. Working		Burst		Max. Working		Burst	
	PSI	Bar	PSI	Bar	PSI	Bar	PSI	Bar	PSI	Bar	PSI	Bar	PSI	Bar	PSI	Bar
1/4"	5000	345	20,000	1,379	-	-	-	-	5000	345	20,000	1,379	5000	345	20,000	1,379
3/8"	5000	345	20,000	1,379	3500	241	17,500	1,207	5000	345	20,000	1,379	5000	345	20,000	1,379
1/2"	5000	345	20,000	1,379	3400	234	17,000	1,172	5000	345	20,000	1,379	5000	345	20,000	1,379
5/8"	5000	345	20,000	1,379	2920	201	14,600	1,007	5000	345	20,000	1,379	5000	345	20,000	1,379
3/4"	5000	345	20,000	1,379	2920	201	14,600	1,007	5000	345	20,000	1,379	5000	345	20,000	1,379
1"	5000	345	20,000	1,379	2920	201	14,600	1,007	5000	345	20,000	1,379	5000	345	20,000	1,379
1-1/2"	3000	207	12,000	828	-	-	-	-	3000	207	12,000	828	3000	207	12,000	828
2"	3000	207	12,000	828	-	-	-	-	3000	207	12,000	828	3000	207	12,000	828

## Technical Specifications:

Body Size	Interchange Standards				Functional Parameters					
	U.S. Military	U.S. Government	International Standards	ANSI/NFPA Standards	Locking Ball Quantity	Air Inclusion	Fluid Loss	Vacuum Inch HG	Flow ΔP = 15 PSI	
1/4"	-	-	ISO16028	-	12	n/a	0.010cc	N/R	3.2 GPM	
3/8"	-	-	ISO16028	T3.20.15	12	n/a	0.010cc	N/R	11 GPM	
1/2"	-	-	ISO16028	-	12	n/a	0.010cc	N/R	18 GPM	
5/8"	-	-	ISO16028	-	12	n/a	0.020cc	N/R	21 GPM	
3/4"	-	-	ISO16028	-	12	n/a	0.030cc	N/R	28 GPM	
1"	-	-	ISO16028	-	12	n/a	0.030cc	N/R	50 GPM	
1-1/2"	-	-	-	-	18	n/a	0.050cc	N/R	140 GPM	
2"	-	-	-	-	20	n/a	0.070cc	N/R	225 GPM	



# HT-Series Hydraulic Couplings

**High Flow Performance!**

High strength laser-cut valve guide maximizes valve stability while minimizing flow restriction.

**Compact Profile!**

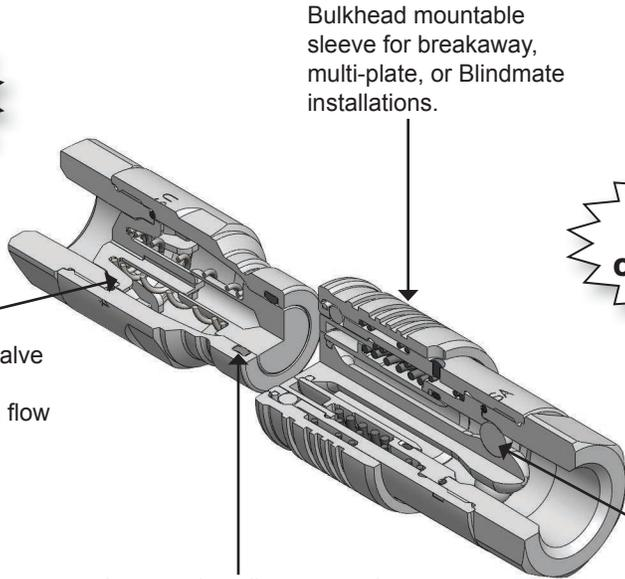

Bulkhead mountable sleeve for breakaway, multi-plate, or Blindmate installations.

**Easily Rebuildable Coupler & Nipple!**

DORS (dual opposing retention spheres) retention system prevents valve stem ejection during surge flow and pressure spike conditions.

Improved sealing system incorporates a high performance molded polyurethane or O-ring energized PTFE valve seal.

## List Price Seal Option Adders:

Body Size	Standard Seal Options												Kalrez® Seal Options						Treatments	
	FKM		EPDM		FDA FKM		Mil-Nitrile		Fuel Nitrile		Silicone		4079		6375		7075		Oxy-Clean	
	Pre	Add\$	Pre	Add\$	Pre	Add\$	Pre	Add\$	Pre	Add\$	Pre	Add\$	Pre	Add\$	Pre	Add\$	Pre	Add\$	Suf	Add\$
1/4"	F-	\$5.00	P-	\$5.00	D-	POR	M-	POR	JF-	POR	S-	POR	K4-	POR	K6-	POR	K7-	POR	-C1	\$16.00
3/8"	F-	5.65	P-	5.65	D-	POR	M-	POR	JF-	POR	S-	POR	K4-	POR	K6-	POR	K7-	POR	-C1	16.00
1/2"	F-	6.84	P-	6.84	D-	POR	M-	POR	JF-	POR	S-	POR	K4-	POR	K6-	POR	K7-	POR	-C1	16.00
5/8"	F-	6.84	P-	6.84	D-	POR	M-	POR	JF-	POR	S-	POR	K4-	POR	K6-	POR	K7-	POR	-C1	19.00
3/4"	F-	7.90	P-	7.90	D-	POR	M-	POR	JF-	POR	S-	POR	K4-	POR	K6-	POR	K7-	POR	-C1	21.00
1"	F-	12.18	P-	12.18	D-	POR	M-	POR	JF-	POR	S-	POR	K4-	POR	K6-	POR	K7-	POR	-C1	24.00
1-1/2"	F-	POR	P-	POR	D-	POR	M-	POR	JF-	POR	S-	POR	K4-	POR	K6-	POR	K7-	POR	-C1	POR
2"	F-	POR	P-	POR	D-	POR	M-	POR	JF-	POR	S-	POR	K4-	POR	K6-	POR	K7-	POR	-C1	POR

# HT-Series Hydraulic Couplings

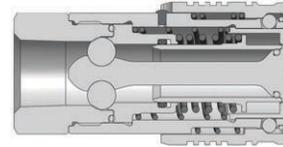

Body Size	HT-Series ISO16028 Flushface Interchange Coupler (Female Threads)											
	Part Detail			List Price	Length		Maximum OD		Hex Inch	Weight Lb	Package Qty	
	Part Number	Threads	Material		Inch	mm	Inch	mm			Bag	Box
1/4"	2HTF2	1/4" - 18 NPTF	steel	<b>\$74.13</b>	1.98	50.3	1.11	28.3	7/8"	0.23	-	25
1/4"	2HTBF2	1/4" - 19 BSPP	steel	<b>74.13</b>	1.98	50.3	1.11	28.3	7/8"	0.23	-	25
1/4"	2HTOF3	9/16" - 18 ORB	steel	<b>77.84</b>	1.98	50.3	1.11	28.3	7/8"	0.23	-	25
3/8"	3HTF3	3/8" - 18 NPTF	steel	<b>76.45</b>	2.50	63.5	1.24	31.5	1"	0.44	-	25
3/8"	3HTF3-SS	3/8" - 18 NPTF	316 stainless	<b>318.81</b>	2.50	63.5	1.24	31.5	1"	0.44	-	25
3/8"	3HTBF3	3/8" - 19 BSPP	steel	<b>76.45</b>	2.50	63.5	1.24	31.5	1"	0.44	-	25
3/8"	3HTBF3-SS	3/8" - 19 BSPP	316 stainless	<b>318.81</b>	2.50	63.5	1.24	31.5	1"	0.44	-	25
3/8"	3HTOF3	9/16" - 18 ORB	steel	<b>76.45</b>	2.50	63.5	1.24	31.5	1"	0.49	-	25
3/8"	3HTF4	1/2" - 14 NPTF	steel	<b>76.45</b>	2.72	69.1	1.24	31.5	1-1/8"	0.48	-	25
3/8"	3HTF4-SS	1/2" - 14 NPTF	316 stainless	<b>318.81</b>	2.72	69.1	1.24	31.5	1-1/8"	0.48	-	25
3/8"	3HTBF4	1/2" - 14 BSPP	steel	<b>76.45</b>	2.72	69.1	1.24	3.5	1-1/8"	0.48	-	25
3/8"	3HTBF4-SS	1/2" - 14 BSPP	316 stainless	<b>318.81</b>	2.72	69.1	1.24	31.5	1-1/8"	0.48	-	25
3/8"	3HTOF4	3/4" - 16 ORB	steel	<b>76.45</b>	2.72	69.1	1.24	31.5	1-1/8"	0.53	-	25
1/2"	4HTF4	1/2" - 14 NPTF	steel	<b>92.66</b>	3.02	76.7	1.54	39.1	1-3/16"	0.86	-	20
1/2"	4HTF4-SS	1/2" - 14 NPTF	316 stainless	<b>360.92</b>	3.02	76.7	1.54	39.1	1-3/16"	0.86	-	20
1/2"	4HTBF4	1/2" - 14 BSPP	steel	<b>92.66</b>	3.02	76.7	1.54	39.1	1-3/16"	0.86	-	20
1/2"	4HTBF4-SS	1/2" - 14 BSPP	316 stainless	<b>360.92</b>	3.02	76.7	1.54	39.1	1-3/16"	0.86	-	20
1/2"	4HTOF4	3/4" - 16 ORB	steel	<b>98.46</b>	3.02	76.7	1.54	39.1	1-3/16"	0.86	-	20
1/2"	4HTOF5	7/8" - 14 ORB	steel	<b>98.46</b>	3.12	79.2	1.54	39.1	1-5/16"	0.92	-	20
1/2"	4HTF6	3/4" - 14 NPTF	steel	<b>98.46</b>	3.22	81.8	1.54	39.1	1-5/16"	0.98	-	20
1/2"	4HTF6-SS	3/4" - 14 NPTF	316 stainless	<b>384.98</b>	3.22	81.8	1.54	39.1	1-5/16"	0.98	-	20
1/2"	4HTBF6	3/4" - 14 BSPP	steel	<b>98.46</b>	3.22	81.8	1.54	39.1	1-5/16"	0.98	-	20
1/2"	4HTBF6-SS	3/4" - 14 BSPP	316 stainless	<b>384.98</b>	3.22	81.8	1.54	39.1	1-5/16"	0.98	-	20
1/2"	4HTOF6	1-1/16" - 12 ORB	steel	<b>98.46</b>	3.42	86.9	1.54	39.1	1-5/16"	0.96	-	20
5/8"	5HTOF5	7/8" - 14 ORB	steel	<b>139.00</b>	3.32	84.3	1.67	42.4	1-1/2"	1.58	-	10
5/8"	5HTF6	3/4" - 14 NPTF	steel	<b>133.20</b>	3.32	84.3	1.67	42.4	1-1/2"	1.51	-	10
5/8"	5HTF6-SS	3/4" - 14 NPTF	316 stainless	<b>505.28</b>	3.32	84.3	1.67	42.4	1-1/2"	1.51	-	10
5/8"	5HTBF6	3/4" - 14 BSPP	steel	<b>133.20</b>	3.32	84.3	1.67	42.4	1-1/2"	1.51	-	10
5/8"	5HTBF6-SS	3/4" - 14 BSPP	316 stainless	<b>505.28</b>	3.32	84.3	1.67	42.4	1-1/2"	1.51	-	10
5/8"	5HTOF6	1-1/16" - 12 ORB	steel	<b>139.00</b>	3.32	84.3	1.67	42.4	1-1/2"	1.49	-	10
3/4"	6HTOF5	7/8" - 14 ORB	steel	<b>202.42</b>	3.70	94.0	1.85	47.0	1-1/2"	1.82	-	10
3/4"	6HTF6	3/4" - 14 NPTF	steel	<b>208.49</b>	3.70	94.0	1.85	47.0	1-1/2"	1.82	-	10
3/4"	6HTF6-SS	3/4" - 14 NPTF	316 stainless	<b>661.68</b>	3.70	94.0	1.85	47.0	1-1/2"	1.82	-	10
3/4"	6HTBF6	3/4" - 14 BSPP	steel	<b>208.49</b>	3.70	94.0	1.85	47.0	1-1/2"	1.82	-	10
3/4"	6HTBF6-SS	3/4" - 14 BSPP	316 stainless	<b>661.68</b>	3.70	94.0	1.85	47.0	1-1/2"	1.82	-	10
3/4"	6HTOF6	1-1/16" - 12 ORB	steel	<b>208.49</b>	3.70	94.0	1.85	47.0	1-1/2"	1.91	-	10
3/4"	6HTF8	1" - 11 1/2 NPTF	steel	<b>208.49</b>	3.82	97.0	1.92	48.8	1-3/4"	2.06	-	10
3/4"	6HTF8-SS	1" - 11 1/2 NPTF	316 stainless	<b>661.68</b>	3.82	97.0	1.92	48.8	1-3/4"	2.06	-	10
3/4"	6HTBF8	1" - 11 BSPP	steel	<b>208.49</b>	3.82	97.0	1.92	48.8	1-3/4"	2.06	-	10
3/4"	6HTBF8-SS	1" - 11 BSPP	316 stainless	<b>661.68</b>	3.82	97.0	1.92	48.8	1-3/4"	2.06	-	10
3/4"	6HTOF8	1-5/16" - 12 ORB	steel	<b>208.49</b>	3.82	97.0	1.92	48.8	1-3/4"	2.16	-	10
1"	8HTF8	1" - 11 1/2 NPTF	steel	<b>289.57</b>	4.24	107.7	2.29	58.2	1-3/4"	2.67	-	10
1"	8HTF8-SS	1" - 11 1/2 NPTF	316 stainless	<b>1142.90</b>	4.24	107.7	2.29	58.2	1-3/4"	2.67	-	10
1"	8HTBF8	1" - 11 BSPP	steel	<b>289.57</b>	4.24	107.7	2.29	58.2	1-3/4"	2.67	-	10
1"	8HTBF8-SS	1" - 11 BSPP	316 stainless	<b>1142.90</b>	4.24	107.7	2.29	58.2	1-3/4"	2.67	-	10
1"	8HTOF8	1-5/16" - 12 ORB	steel	<b>289.57</b>	4.24	107.7	2.29	58.2	1-3/4"	2.68	-	10
1"	8HTF10	1-1/4" - 11 1/2 NPTF	steel	<b>301.15</b>	4.34	110.2	2.29	58.2	2"	2.75	-	10
1"	8HTF10-SS	1-1/4" - 11 1/2 NPTF	316 stainless	<b>1203.06</b>	4.34	110.2	2.29	58.2	2"	2.75	-	10
1"	8HTBF10	1-1/4" - 11 BSPP	steel	<b>301.15</b>	4.29	109.0	2.29	58.2	2"	2.75	-	10
1"	8HTBF10-SS	1-1/4" - 11 BSPP	316 stainless	<b>1203.06</b>	4.29	109.0	2.29	58.2	2"	2.75	-	10
1"	8HTOF10	1-5/8" - 12 ORB	steel	<b>301.15</b>	4.24	107.7	2.29	58.2	2"	2.84	-	10

# HT-Series Hydraulic Couplings

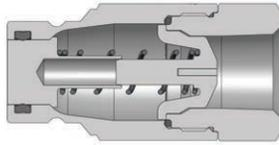

Body Size	HT-Series ISO16028 Flushface Interchange Nipple (Female Threads)											
	Part Detail			List Price	Length		Maximum OD		Hex Inch	Weight Lb	Package Qty	
	Part Number	Threads	Material		Inch	mm	Inch	mm			Bag	Box
1/4"	HT2F2	1/4" - 18 NPTF	steel	30.12	1.89	48.00	0.97	24.6	7/8"	0.16	-	25
1/4"	HT2BF2	1/4" - 19 BSPP	steel	30.12	1.89	48.00	0.97	24.6	7/8"	0.16	-	25
1/4"	HT2OF3	9/16" - 18 ORB	steel	31.62	1.89	48.00	0.97	24.6	7/8"	0.16	-	25
3/8"	HT3F3	3/8" - 18 NPTF	steel	32.43	2.48	63.0	1.10	27.9	1"	0.27	-	25
3/8"	HT3F3-SS	3/8" - 18 NPTF	316 stainless	126.33	2.48	63.0	1.10	27.9	1"	0.27	-	25
3/8"	HT3BF3	3/8" - 19 BSPP	steel	32.43	2.48	63.0	1.10	27.9	1"	0.27	-	25
3/8"	HT3BF3-SS	3/8" - 19 BSPP	316 stainless	126.33	2.48	63.0	1.10	27.9	1"	0.27	-	25
3/8"	HT3OF3	9/16" - 18 ORB	steel	32.43	2.48	63.0	1.10	27.9	1"	0.34	-	25
3/8"	HT3F4	1/2" - 14 NPTF	steel	32.43	2.70	68.6	1.24	31.5	1-1/8"	0.31	-	25
3/8"	HT3F4-SS	1/2" - 14 NPTF	316 stainless	126.33	2.70	68.6	1.24	31.5	1-1/8"	0.31	-	25
3/8"	HT3BF4	1/2" - 14 BSPP	steel	32.43	2.70	68.6	1.24	31.5	1-1/8"	0.31	-	25
3/8"	HT3BF4-SS	1/2" - 14 BSPP	316 stainless	126.33	2.70	68.6	1.24	31.5	1-1/8"	0.31	-	25
3/8"	HT3OF4	3/4" - 16 ORB	steel	32.43	2.70	68.6	1.24	31.5	1-1/8"	0.35	-	25
1/2"	HT4F4	1/2" - 14 NPTF	steel	52.12	2.63	66.8	1.31	33.3	1-3/16"	0.42	-	20
1/2"	HT4F4-SS	1/2" - 14 NPTF	316 stainless	216.55	2.63	66.8	1.31	33.3	1-3/16"	0.42	-	20
1/2"	HT4BF4	1/2" - 14 BSPP	steel	52.12	2.63	66.8	1.31	33.3	1-3/16"	0.42	-	20
1/2"	HT4BF4-SS	1/2" - 14 BSPP	316 stainless	216.55	2.63	66.8	1.31	33.3	1-3/16"	0.42	-	20
1/2"	HT4OF4	3/4" - 16 ORB	steel	57.92	2.63	66.8	1.31	33.3	1-3/16"	0.40	-	20
1/2"	HT4OF5	7/8" - 14 ORB	steel	57.92	2.63	69.3	1.31	33.3	1-5/16"	0.43	-	20
1/2"	HT4F6	3/4" - 14 NPTF	steel	57.92	2.73	71.9	1.44	36.6	1-5/16"	0.53	-	20
1/2"	HT4F6-SS	3/4" - 14 NPTF	316 stainless	240.61	2.83	71.9	1.44	36.6	1-5/16"	0.53	-	20
1/2"	HT4BF6	3/4" - 14 BSPP	steel	57.92	2.83	71.9	1.44	36.6	1-5/16"	0.53	-	20
1/2"	HT4BF6-SS	3/4" - 14 BSPP	316 stainless	240.61	2.83	71.9	1.44	36.6	1-5/16"	0.53	-	20
1/2"	HT4OF6	1-1/16" - 12 ORB	steel	57.92	3.03	77.0	1.44	36.6	1-5/16"	0.58	-	20
5/8"	HT5OF5	7/8" - 14 ORB	steel	74.13	2.88	73.2	1.65	41.9	1-1/2"	0.90	-	10
5/8"	HT5F6	3/4" - 14 NPTF	steel	74.13	2.88	73.2	1.65	41.9	1-1/2"	0.95	-	10
5/8"	HT5F6-SS	3/4" - 14 NPTF	316 stainless	288.74	2.88	73.2	1.65	41.9	1-1/2"	0.95	-	10
5/8"	HT5BF6	3/4" - 14 BSPP	steel	74.13	2.88	73.2	1.65	41.9	1-1/2"	0.95	-	10
5/8"	HT5BF6-SS	3/4" - 14 BSPP	316 stainless	288.74	2.88	73.2	1.65	41.9	1-1/2"	0.95	-	10
5/8"	HT5OF6	1-1/16" - 12 ORB	steel	74.13	2.88	73.2	1.65	41.9	1-1/2"	1.02	-	10
3/4"	HT6OF5	7/8" - 14 ORB	steel	92.22	3.42	86.9	1.65	41.9	1-1/2"	1.00	-	10
3/4"	HT6F6	3/4" - 14 NPTF	steel	94.98	3.42	86.9	1.65	41.9	1-1/2"	1.00	-	10
3/4"	HT6F6-SS	3/4" - 14 NPTF	316 stainless	445.14	3.42	86.9	1.65	41.9	1-1/2"	1.00	-	10
3/4"	HT6BF6	3/4" - 14 BSPP	steel	94.98	3.42	86.9	1.65	41.9	1-1/2"	1.00	-	10
3/4"	HT6BF6-SS	3/4" - 14 BSPP	316 stainless	445.14	3.42	86.9	1.65	41.9	1-1/2"	1.00	-	10
3/4"	HT6OF6	1-1/16" - 12 ORB	steel	94.98	3.42	86.9	1.65	41.9	1-1/2"	1.02	-	10
3/4"	HT6F8	1" - 11 1/2 NPTF	steel	94.98	3.54	89.9	1.92	48.8	1-3/4"	1.15	-	10
3/4"	HT6F8-SS	1" - 11 1/2 NPTF	316 stainless	445.14	3.54	89.9	1.92	48.8	1-3/4"	1.15	-	10
3/4"	HT6BF8	1" - 11 BSPP	steel	94.98	3.54	89.9	1.92	48.8	1-3/4"	1.15	-	10
3/4"	HT6BF8-SS	1" - 11 BSPP	316 stainless	445.14	3.54	89.9	1.92	48.8	1-3/4"	1.15	-	10
3/4"	HT6OF8	1-5/16" - 12 ORB	steel	94.98	3.54	89.9	1.92	48.8	1-3/4"	1.12	-	10
1"	HT8F8	1" - 11 1/2 NPTF	steel	179.54	3.50	88.9	1.96	49.8	1-3/4"	1.69	-	10
1"	HT8F8-SS	1" - 11 1/2 NPTF	316 stainless	643.64	3.50	88.9	1.96	49.8	1-3/4"	1.69	-	10
1"	HT8BF8	1" - 11 BSPP	steel	179.54	3.50	88.9	1.96	49.8	1-3/4"	1.69	-	10
1"	HT8BF8-SS	1" - 11 BSPP	316 stainless	643.64	3.50	88.9	1.96	49.8	1-3/4"	1.69	-	10
1"	HT8OF8	1-5/16" - 12 ORB	steel	179.54	3.50	88.9	1.96	49.8	1-3/4"	1.65	-	10
1"	HT8F10	1-1/4" - 11 1/2 NPTF	steel	179.54	3.61	91.7	2.19	55.6	2"	1.84	-	10
1"	HT8F10-SS	1-1/4" - 11 1/2 NPTF	316 stainless	643.64	3.61	91.7	2.19	55.6	2"	1.84	-	10
1"	HT8BF10	1-1/4" - 11 BSPP	steel	179.54	3.55	90.2	2.19	55.6	2"	1.84	-	10
1"	HT8BF10-SS	1-1/4" - 11 BSPP	316 stainless	643.64	3.55	90.2	2.19	55.6	2"	1.84	-	10
1"	HT8OF10	1-5/8" - 12 ORB	steel	179.54	3.51	89.2	2.19	55.6	2"	1.93	-	10

## HT-Series Hydraulic Couplings

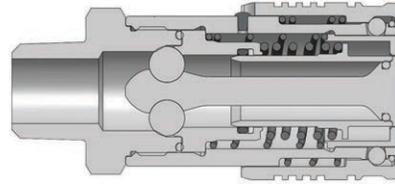

Body Size	HT-Series ISO16028 Flushface Interchange Coupler (Male Threads)											
	Part Detail			List Price	Length		Maximum OD		Hex Inch	Weight Lb	Package Qty	
	Part Number	Threads	Material		Inch	mm	Inch	mm			Bag	Box
3/8"	3HTM3	3/8" - 18 NPTF	steel	<b>\$81.08</b>	2.88	73.2	1.24	31.5	1-1/8"	0.46	5	25
3/8"	3HTM4	1/2" - 14 NPTF	steel	<b>81.08</b>	2.97	75.4	1.24	31.5	1-1/8"	0.48	5	25
1/2"	4HTM4	1/2" - 14 NPTF	steel	<b>98.46</b>	3.42	86.9	1.54	39.1	1-5/16"	0.97	-	20

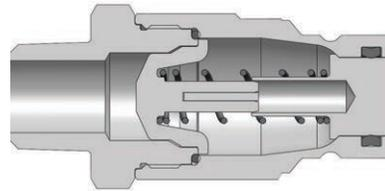

Body Size	HT-Series ISO16028 Flushface Interchange Nipple (Male Threads)											
	Part Detail			List Price	Length		Maximum OD		Hex Inch	Weight Lb	Package Qty	
	Part Number	Threads	Material		Inch	mm	Inch	mm			Bag	Box
3/8"	HT3M3	3/8" - 18 NPTF	steel	<b>\$37.07</b>	2.87	72.9	1.24	31.5	1-1/8"	0.31	5	25
3/8"	HT3M4	1/2" - 14 NPTF	steel	<b>37.07</b>	2.96	75.2	1.24	31.5	1-1/8"	0.38	5	25
1/2"	HT4M4	1/2" - 14 NPTF	steel	<b>63.71</b>	3.03	77.0	1.44	36.6	1-5/16"	0.42	-	20

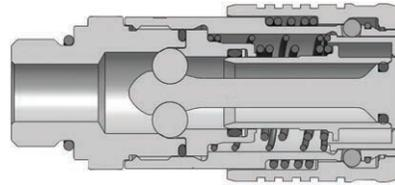

Body Size	HT-Series ISO16028 Flushface Interchange Coupler (Male ORB Threads)											
	Part Detail			List Price	Length		Maximum OD		Hex Inch	Weight Lb	Package Qty	
	Part Number	Threads	Material		Inch	mm	Inch	mm			Bag	Box
3/8"	3HTOM3	9/16" - 18 ORB	steel	<b>81.08</b>	2.75	69.9	1.24	31.5	1-1/8"	0.47	5	25
3/8"	3HTOM4	3/4" - 16 ORB	steel	<b>81.08</b>	2.75	69.9	1.24	31.5	1-1/8"	0.47	5	25

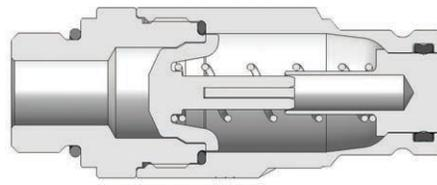

Body Size	HT-Series ISO16028 Flushface Interchange Nipple (Male ORB Threads)											
	Part Detail			List Price	Length		Maximum OD		Hex Inch	Weight Lb	Package Qty	
	Part Number	Threads	Material		Inch	mm	Inch	mm			Bag	Box
3/8"	HT3OM3	9/16" - 18 ORB	steel	<b>\$37.07</b>	2.73	69.3	1.17	29.7	1-1/8"	0.47	5	25
3/8"	HT3OM4	3/4" - 16 ORB	steel	<b>\$37.07</b>	2.73	69.3	1.17	29.7	1-1/8"	0.47	5	25

## HT-Series Hydraulic Couplings

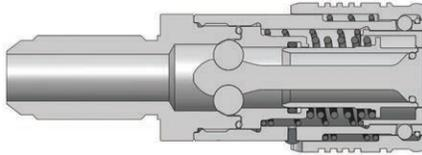

Body Size	HT-Series ISO16028 Flushface Interchange Coupler (Male Bulkhead Threads)											
	Part Detail			List Price	Length		Maximum OD		Hex Inch	Weight Lb	Package Qty	
	Part Number	Threads	Material		Inch	mm	Inch	mm			Bag	Box
1/2"	4HTJB5	7/8" - 14 JIC BH	steel	\$101.93	4.38	111.3	1.54	39.1	1-5/16"	1.08	-	20
1/2"	4HTRB5	1" - 14 ORFS BH	steel	101.93	4.37	111.0	1.54	39.1	1-5/16"	1.11	-	20
1/2"	4HTJB6	1-1/16" - 12 JIC BH	steel	101.93	4.55	115.6	1.54	39.1	1-5/16"	1.22	-	20

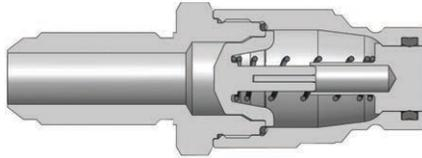

Body Size	HT-Series ISO16028 Flushface Interchange Nipple (Male Bulkhead Threads)											
	Part Detail			List Price	Length		Maximum OD		Hex Inch	Weight Lb	Package Qty	
	Part Number	Threads	Material		Inch	mm	Inch	mm			Bag	Box
1/2"	HT4JB5	7/8" - 14 JIC BH	steel	\$63.71	3.99	101.3	1.44	36.6	1-5/16"	0.42	-	20
1/2"	HT4RB5	1" - 14 ORFS BH	steel	63.71	3.98	101.1	1.44	36.6	1-5/16"	0.49	-	20
1/2"	HT4JB6	1-1/16" - 12 JIC BH	steel	69.49	4.16	115.6	1.44	36.6	1-5/16"	0.54	-	20

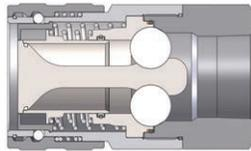

NEW 2014

Body Size	HT-Series ISO16028 Flushface Interchange Coupler (Female Threads)											
	Part Detail			List Price	Length		Maximum OD		Hex Inch	Weight Lb	Package Qty	
	Part Number	Threads	Material		Inch	mm	Inch	mm			Bag	Box
1-1/2"	12HTF12	1-1/2" - 11 1/2 NPT	steel	1098.63	5.23	132.7	3.37	85.5	2-1/2"	7.6	-	1
1-1/2"	12HTBF12	1-1/2" - 11 BSPP	steel	1098.63	5.23	132.7	3.37	85.5	2-1/2"	7.6	-	1
1-1/2"	12HTOF12	1-7/8" - 12 ORB	steel	1153.56	5.23	132.7	3.37	85.5	2-1/2"	7.6	-	1
2"	16HTF16	2" - 11 1/2 NPTF	steel	1318.35	6.75	171.3	3.95	100.3	3-1/2"	13.8	-	1
2"	16HTBF16	2" - 11 BSPP	steel	1318.35	6.75	171.3	3.95	100.3	3-1/2"	13.8	-	1
2"	16HTOF16	2-1/2" - 12 ORB	steel	1384.26	6.75	171.3	3.95	100.3	3-1/2"	13.8	-	1

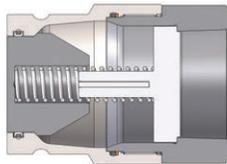

NEW 2014

Body Size	HT-Series ISO16028 Flushface Interchange Nipple (Female Threads)											
	Part Detail			List Price	Length		Maximum OD		Hex Inch	Weight Lb	Package Qty	
	Part Number	Threads	Material		Inch	mm	Inch	mm			Bag	Box
1-1/2"	HT12F12	1-1/2" - 11 1/2 NPT	steel	590.39	4.25	107.9	2.75	69.8	2-1/2"	3.5	-	1
1-1/2"	HT12BF12	1-1/2" - 11 BSPP	steel	590.39	4.25	107.9	2.75	69.8	2-1/2"	3.5	-	1
1-1/2"	HT12OF12	1-7/8" - 12 ORB	steel	619.91	4.25	107.9	2.75	69.8	2-1/2"	3.5	-	1
2"	HT16F16	2" - 11 1/2 NPTF	steel	708.46	4.62	117.3	3.29	83.5	3"	5.1	-	1
2"	HT16BF16	2" - 11 BSPP	steel	708.46	4.62	117.3	3.29	83.5	3"	5.1	-	1
2"	HT16OF16	2-1/2" - 12 ORB	steel	743.89	4.62	117.3	3.29	83.5	3"	5.1	-	1

## HT-Series Hydraulic Couplings



Body Size	HT-Series ISO16028 Flushface Coupler Dust Plug					
	Part Detail		List Price	Weight Lb	Package Qty	
	Part Number	Body			Bag	Box
1/4"	2HTDP	Nitrile	<b>\$7.70</b>	0.05	5	50
3/8"	3HTDP	Nitrile	<b>8.58</b>	0.05	5	50
1/2"	4HTDP	Nitrile	<b>11.36</b>	0.06	5	50
5/8"	5HTDP	Nitrile	<b>13.37</b>	0.07	5	50
3/4"	6HTDP	Nitrile	<b>14.37</b>	0.07	5	50
1"	8HTDP	Nitrile	<b>16.49</b>	0.15	5	50



Body Size	HT-Series ISO16028 Flushface Nipple Dust Cap					
	Part Detail		List Price	Weight Lb	Package Qty	
	Part Number	Body			Bag	Box
1/4"	HT2DC	Nitrile	<b>\$7.70</b>	0.04	5	50
3/8"	HT3DC	Nitrile	<b>8.58</b>	0.04	5	50
1/2"	HT4DC	Nitrile	<b>11.36</b>	0.04	5	50
5/8"	HT5DC	Nitrile	<b>13.37</b>	0.06	5	50
3/4"	HT6DC	Nitrile	<b>14.37</b>	0.06	5	50
1"	HT8DC	Nitrile	<b>16.49</b>	0.10	5	50

### Using the Nipple Profile Dimensions to Select Proper Size

ISO16028 Body Size	Minimum Dimension 'X' Measurement	Maximum Dimension 'X' Measurement
1/4"	0.634" (16.10 mm)	0.638" (16.20 mm)
3/8"	0.774" (19.66 mm)	0.779" (19.79 mm)
1/2"	0.963" (24.45 mm)	0.968" (24.58 mm)
5/8"	1.061" (26.95 mm)	1.066" (27.08 mm)
3/4"	1.176" (29.87 mm)	1.181" (30.00 mm)
1"	1.415" (35.94mm)	1.420" (36.07 mm)

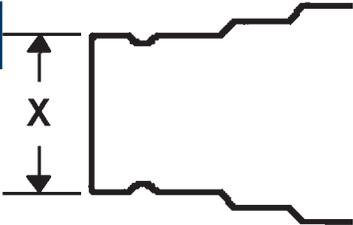

### Using the Profile Layover to Select Proper Size

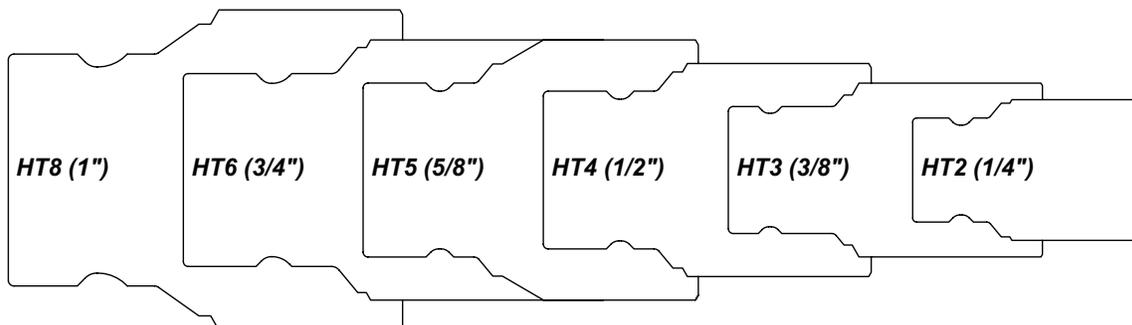

## HT-Series Hydraulic Couplings

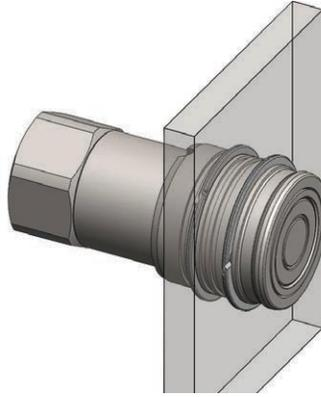

Body Size	HT-Series ISO16028 Flushface Interchange Coupler Bulkhead Kits						
	Part Detail			List Price	Bulkhead Kit Contents	Package Qty	
	Part Number	Mounting Hole ID	Ring Material			Bag	Box
1/4"	2HT-BMK	1.125"	Steel	<b>\$4.32</b>	Two 360° Retaining Rings	1	25
3/8"	3HT-BMK	1.250"	Steel	<b>4.73</b>	Two 360° Retaining Rings	1	25
1/2"	4HT-BMK	1.560"	Steel	<b>5.17</b>	Two 360° Retaining Rings	1	25
5/8"	5HT-BMK	1.685"	Steel	<b>5.23</b>	Two 360° Retaining Rings	1	25
3/4"	6HT-BMK	1.870"	Steel	<b>5.84</b>	Two 360° Retaining Rings	1	25
1"	8HT-BMK	2.310"	Steel	<b>7.20</b>	Two 360° Retaining Rings	1	25

Body Size	HT-Series ISO16028 Flushface Interchange Coupler Seal Kits						
	Part Detail			List Price	Seal Kit Contents	Package Qty	
	Part Number	Coupler Style	Seal Material			Bag	Box
1/4"	2HT-SKIT	all	Nitrile	<b>\$4.88</b>	Stem/Adapter/Gland O-Ring, Gland B.U.	25	200
3/8"	3HT-SKIT	all	Nitrile	<b>5.47</b>	Stem/Adapter/Gland O-Ring, Gland B.U.	25	200
1/2"	4HT-SKIT	all	Nitrile	<b>5.95</b>	Stem/Adapter/Gland O-Ring, Gland B.U.	25	200
5/8"	5HT-SKIT	all	Nitrile	<b>6.37</b>	Stem/Adapter/Gland O-Ring, Gland B.U.	25	200
3/4"	6HT-SKIT	all	Nitrile	<b>6.52</b>	Stem/Adapter/Gland O-Ring, Gland B.U.	25	200
1"	8HT-SKIT	all	Nitrile	<b>7.68</b>	Stem/Adapter/Gland O-Ring, Gland B.U.	25	200

Body Size	HT-Series ISO16028 Flushface Interchange Nipple Seal Kits						
	Part Detail			List Price	Seal Kit Contents	Package Qty	
	Part Number	Nipple Style	Seal Material			Bag	Box
1/4"	HT2-SKIT-V2	all	Nitrile	<b>\$5.69</b>	Main Valve Seal and Adapter O-Ring	25	200
3/8"	HT3-SKIT-V2	all	Nitrile	<b>6.80</b>	Main Valve Seal and Adapter O-Ring	25	200
1/2"	HT4-SKIT-V2	all	Nitrile	<b>7.07</b>	Main Valve Seal and Adapter O-Ring	25	200
5/8"	HT5-SKIT-V2	all	Nitrile	<b>7.52</b>	Main Valve Seal and Adapter O-Ring	25	200
3/4"	HT6-SKIT-V2	all	Nitrile	<b>9.17</b>	Main Valve Seal and Adapter O-Ring	25	200
1"	HT8-SKIT-V2	all	Nitrile	<b>9.73</b>	Main Valve Seal and Adapter O-Ring	25	200

# HTE-Series Hydraulic Couplings

**NEW** 2014

## Interchange Data:

- Parker FEC-Series, Stucchi APM-Series, Faster 3FFH-Series

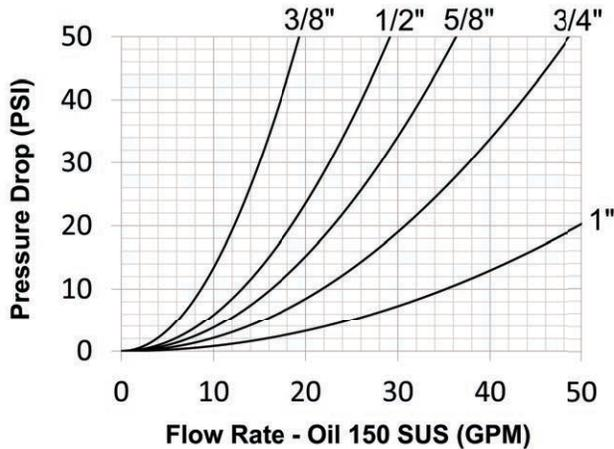

## Materials:

- Machined components are manufactured using solid steel bar stock.
- Steel componentry is plated using a ROHS Compliant Zinc Nickel process providing superior corrosion resistance.
- Stainless steel retaining rings and springs maximize corrosion resistance and extend service life.
- Nipples are hardened to provide resistance to brinelling during impulse service.

## Seal Components:

- 3/8", 1/2", and 3/4" nipples have molded Polyurethane valve seals, with a temperature range of -65°F to +212°F (-54°C to +100°C).
- 5/8" and 1" nipples have Nitrile-Energized PTFE valve seals, with a temperature range of -40°F to +250°F (-40°C to +121°C).
- Ancillary nipple seals are Nitrile (Buna-N), temperature range of -40°F to +250°F (-40°C to +121°C).

## Component Terminology

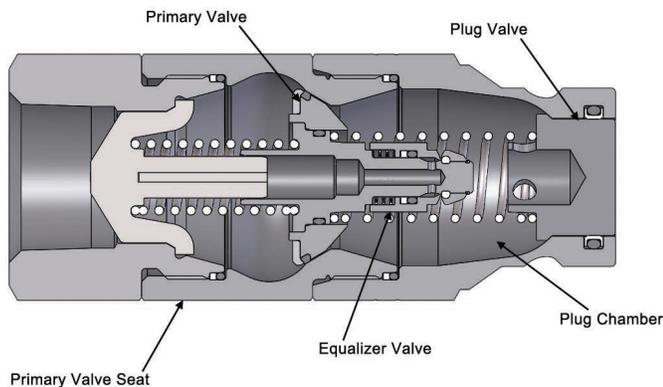

## Benefits of the new Equalizer valve system!

- Non-linear connection force at all pressures
- No maximum connection-pressure restrictions
- Head pressure or valve bleed-by has minimal effect on connection force
- Less susceptible to system contamination
- Design is scalable performing similarly in all sizes
- Smooth connection action

## Rated Pressure Chart:

HTE-Series ISO16028 Connect Under Pressure Flushface Nipple												
Body Size	Steel HT Coupler/ HTE-Plug Coupled				HTE-Plug Uncoupled				Air Inclusion	Fluid Loss	Vacuum Inch HG	Flow $\Delta P = 14.5$ PSI
	Max. Working		Burst		Max. Working		Burst					
	PSI	Bar	PSI	Bar	PSI	Bar	PSI	Bar				
3/8"	5000	345	20,000	1,380	5000	345	20,000	1,380	n/a	0.010cc	N/R	9.5 GPM
1/2"	5000	345	20,000	1,380	5000	345	20,000	1,380	n/a	0.010cc	N/R	15 GPM
5/8"	5000	345	20,000	1,380	5000	345	20,000	1,380	n/a	0.020cc	N/R	18 GPM
3/4"	5000	345	20,000	1,380	5000	345	20,000	1,380	n/a	0.030cc	N/R	24 GPM
1"	5000	345	20,000	1,380	5000	345	20,000	1,380	n/a	0.030cc	N/R	44 GPM



# HTE-Series Hydraulic Couplings

## The Equalizer Connection Process

2014  
**NEW**

### Stage 1: The Disconnected State

The plug has residual pressure trapped behind the primary valve, while the coupler has no trapped pressure.

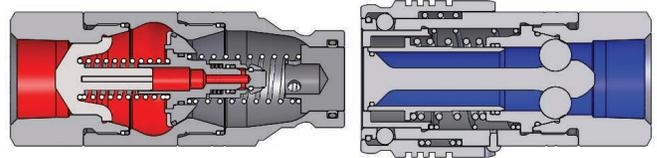

### Stage 2: Plug Chamber Evacuated

The plug valve is opened, then the socket valve opens, evacuating the plug chamber to the unpressurized socket.

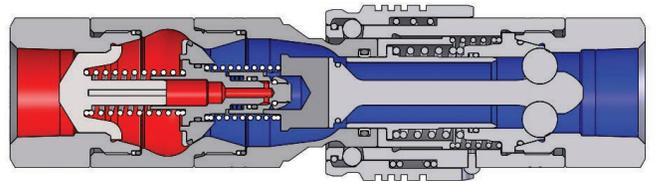

### Stage 3: Release Pressure

The connection continues, with the Equalizer valve being activated, releasing the trapped pressure into the plug chamber, then to the unpressurized socket.

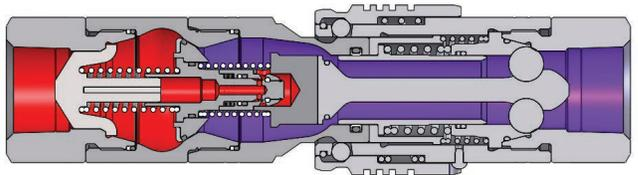

### Stage 4: Complete the connection

The primary valve can now open easily, since there is no longer any pressure trapped behind it, allowing the socket to fully engage the plug.

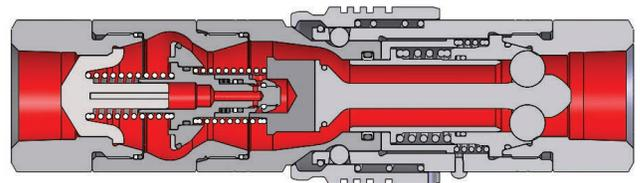

## HTE-Series Hydraulic Couplings

**NEW** 2014

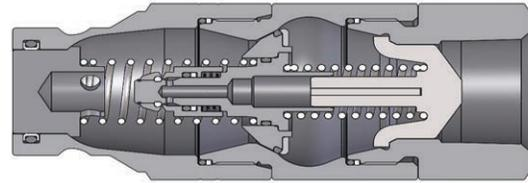

- For use with HT-Series Couplers

Body Size	HTE-Series ISO 16028 Connect Under Pressure Flush Face Nipple (Female Threads)											
	Part Detail			List Price	Length		Maximum OD		Hex mm	Weight Lb	Package Qty	
	Part Number	Threads	Material		Inch	mm	Inch	mm			Bag	Box
3/8"	HTE3F4	1/2"-14 NPTF	steel	<b>\$65.00</b>	3.25	82.6	1.30	33.0	1-1/8"	0.95	-	10
3/8"	HTE3BF4	1/2"-14 BSPP	steel	<b>68.77</b>	3.25	82.6	1.30	33.0	1-1/8"	0.95	-	10
3/8"	HTE3OF4	3/4"-16 ORB	steel	<b>66.44</b>	3.25	82.6	1.30	33.0	1-1/8"	0.95	-	10
1/2"	HTE4F4	1/2"-14 NPTF	steel	<b>77.10</b>	3.40	86.4	1.30	33.0	1-3/16"	1.07	-	10
1/2"	HTE4BF4	1/2"-14 BSPP	steel	<b>80.88</b>	3.40	86.4	1.30	33.0	1-3/16"	1.07	-	10
1/2"	HTE4OF4	3/4"-16 ORB	steel	<b>80.07</b>	3.40	86.4	1.30	33.0	1-3/16"	1.07	-	10
1/2"	HTE4OF5	7/8"-14 ORB	steel	<b>80.07</b>	3.40	86.4	1.30	33.0	1-1/2"	1.10	-	10
1/2"	HTE4F6	3/4"-14 NPTF	steel	<b>78.54</b>	3.60	91.4	1.65	41.9	1-1/2"	1.10	-	10
1/2"	HTE4BF6	3/4"-14 BSPP	steel	<b>81.21</b>	3.60	91.4	1.65	41.9	1-1/2"	1.10	-	10
1/2"	HTE4OF6	1-1/16"-12 ORB	steel	<b>80.07</b>	3.60	91.4	1.65	41.9	1-1/2"	1.10	-	10
5/8"	HTE5OF5	7/8"-14 ORB	steel	<b>146.47</b>	3.75	95.3	1.65	41.9	1-1/2"	1.55	-	10
5/8"	HTE5F6	3/4"-14 NPTF	steel	<b>145.00</b>	3.75	95.3	1.65	41.9	1-1/2"	1.55	-	10
5/8"	HTE5BF6	3/4"-14 BSPP	steel	<b>150.68</b>	3.75	95.3	1.65	41.9	1-1/2"	1.55	-	10
5/8"	HTE5OF6	1-1/16"-12 ORB	steel	<b>146.47</b>	3.75	95.3	1.65	41.9	1-1/2"	1.75	-	10
3/4"	HTE6F6	3/4"-14 NPTF	steel	<b>171.63</b>	4.25	108.0	1.96	49.8	1-1/2"	1.80	-	5
3/4"	HTE6BF6	3/4"-14 BSPP	steel	<b>171.63</b>	4.25	108.0	1.96	49.8	1-1/2"	1.80	-	5
3/4"	HTE6OF6	1-1/16"-12 ORB	steel	<b>173.09</b>	4.25	108.0	1.96	49.8	1-1/2"	1.80	-	5
3/4"	HTE6F8	1"-11 1/2 NPTF	steel	<b>171.63</b>	4.40	111.8	1.96	49.8	1-3/4"	2.10	-	5
3/4"	HTE6BF8	1"-11 BSPP	steel	<b>182.97</b>	4.40	111.8	1.96	49.8	1-3/4"	2.10	-	5
3/4"	HTE6OF8	1-5/16"-12 ORB	steel	<b>173.09</b>	4.40	111.8	1.96	49.8	1-3/4"	2.10	-	5
1"	HTE8F8	1"-11 1/2 NPTF	steel	<b>370.17</b>	4.88	124.0	1.96	49.8	1-3/4"	2.15	-	5
1"	HTE8BF8	1"-11 BSPP	steel	<b>370.17</b>	4.88	124.0	1.96	49.8	1-3/4"	2.15	-	5
1"	HTE8OF8	1-5/16"-12 ORB	steel	<b>370.17</b>	4.88	124.0	1.96	49.8	1-3/4"	2.15	-	5
1"	HTE8F10	1-1/4"-11 1/2 NPTF	steel	<b>370.17</b>	5.00	127.0	2.47	62.7	2-3/16"	2.40	-	5
1"	HTE8BF10	1-1/4"-11 BSPP	steel	<b>370.17</b>	5.00	127.0	2.47	62.7	2-3/16"	2.40	-	5
1"	HTE8OF10	1-5/8"-12 ORB	steel	<b>370.17</b>	5.00	127.0	2.47	62.7	2-3/16"	2.40	-	5

# ST-Series Hydraulic Couplings

## Interchange Data:

- Interchangeable with Snap-Tite 71-Series

## Materials:

- Machined components are manufactured using solid steel or 316 stainless bar stock.
- Stainless steel balls, retaining rings, and springs maximize corrosion resistance and extend service life.
- Steel componentry is plated using ROHS Compliant Trivalent Chrome.
- Steel coupler sleeves are hardened to resist deformation and maximize service life.
- Steel nipples are hardened to provide heavy duty performance.

## Seal Components:

- Nitrile (Buna-N) seals are standard, providing a temperature range of -40°F to +250°F (-40°C to +121°C).
- All couplers and nipples incorporate PTFE or TPC-ET anti-extrusion rings to protect the seal components from dynamic impulse damage.

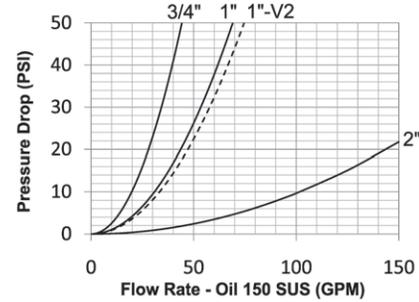
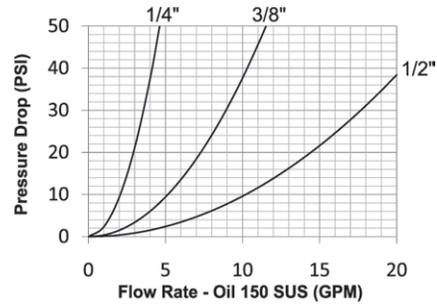

## Rated Pressure Chart:

Body Size	ST-Series Snap-Tite 71-Series Interchange							
	Steel Coupler/Plug Coupled				316 Stainless Coupler/Plug Coupled			
	Maximum Working		Burst		Maximum Working		Burst	
	PSI	Bar	PSI	Bar	PSI	Bar	PSI	Bar
1/4"	10,000	700	27,300	1,800	5,000	345	28,000	1,900
3/8"	10,000	700	27,300	1,800	5,000	345	28,000	1,900
1/2"	10,000	700	22,500	1,500	5,000	345	25,000	1,700
3/4"	7,500	500	20,200	1,400	5,000	345	22,800	1,550
1"	7,500	500	19,400	1,300	4,000	275	18,500	1,250
1"-V2	8,500	585	25,900	1,750	-	-	-	-
2"	5,000	345	16,000	1,100	3,000	200	10,000	700

## Technical Specifications:

Body Size	Interchange Standards				Functional Parameters				
	U.S. Military	U.S. Government	International Standards	ANSI/NFPA Standards	Locking Ball Quantity	Air Inclusion	Fluid Loss	Vacuum Inch HG	Flow ΔP = 22 PSI
1/4"	-	-	-	-	10	0.01cc	0.02cc	N/R	3.1 GPM
3/8"	-	-	-	-	10	0.02cc	0.02cc	N/R	7.7 GPM
1/2"	-	-	-	-	12	0.03cc	0.03cc	N/R	15 GPM
3/4"	-	-	-	-	12	0.04cc	0.06cc	N/R	30 GPM
1"	-	-	-	-	12	0.06cc	0.07cc	N/R	45 GPM
1"-V2	-	-	-	-	12	0.09cc	0.10cc	N/R	50 GPM
2"	-	-	-	-	15	3.14cc	5.25cc	N/R	150 GPM

Note: Minimum burst pressure ratings were established under laboratory conditions using a Static Burst Unit (SBU). For high impulse applications and to meet Det Norske Veritas (DNV) compliance, the burst pressure must be divided by four (4) to ensure a 4:1 safety factor during system operation.

## ST-Series Hydraulic Couplings

### List Price Option Adders:

Body Size	Standard Seal Options								Kalrez® Seal Options						Sleeve		Treatments	
	FKM		EPDM		Mil-Nitrile		Fuel Nitrile		4079		6375		7075		Locking		Oxy-Clean	
	Pre	Add \$	Pre	Add \$	Pre	Add \$	Pre	Add \$	Pre	Add \$	Pre	Add \$	Pre	Add \$	Suf	Add \$	Suf	Add \$
1/4"	F-	\$0.00	P-	\$2.69	M-	\$2.80	JF-	\$2.75	K4-	POR	K6-	POR	K7-	POR	-LS	\$3.90	-C1	\$16.00
3/8"	F-	0.00	P-	4.48	M-	4.38	JF-	4.53	K4-	POR	K6-	POR	K7-	POR	-LS	4.50	-C1	16.00
1/2"	F-	0.00	P-	6.16	M-	5.49	JF-	5.65	K4-	POR	K6-	POR	K7-	POR	-LS	4.50	-C1	16.00
3/4"	F-	0.00	P-	8.90	M-	7.11	JF-	7.61	K4-	POR	K6-	POR	K7-	POR	-LS	11.50	-C1	19.00
1"	F-	0.00	P-	11.17	M-	9.06	JF-	9.22	K4-	POR	K6-	POR	K7-	POR	-LS	11.50	-C1	21.00
1"-V2	F-	0.00	P-	11.17	M-	9.06	JF-	9.22	K4-	POR	K6-	POR	K7-	POR	-LS	11.50	-C1	21.00
2"	F-	0.00	P-	21.19	M-	18.74	JF-	19.46	K4-	POR	K6-	POR	K7-	POR	-LS	14.40	-C1	24.00

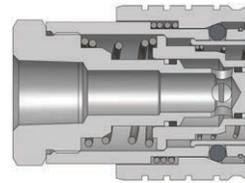

Body Size	ST-Series Snap-Tite 71-Series Interchange Coupler (Female Threads)											
	Part Detail			List Price	Length		Maximum OD		Hex Inch	Weight Lb	Package Qty	
	Part Number	Threads	Material		Inch	mm	Inch	mm			Bag	Box
1/4"	2STF2	1/4" - 18 NPTF	steel	\$86.78	1.96	49.8	1.23	31.2	15/16"	0.25	5	25
1/4"	2STF2-SS	1/4" - 18 NPTF	316 stainless	246.02	1.96	49.8	1.23	31.2	15/16"	0.26	5	25
1/4"	2STBF2	1/4" - 19 BSPP	steel	86.78	1.96	49.8	1.23	31.2	15/16"	0.25	5	25
1/4"	2STBF2-SS	1/4" - 19 BSPP	316 stainless	246.02	1.96	49.8	1.23	31.2	15/16"	0.26	5	25
3/8"	3STF2	1/4" - 18 NPTF	steel	82.12	2.36	59.9	1.6	40.6	1-3/16"	0.38	5	25
3/8"	3STF3	3/8" - 18 NPTF	steel	82.12	2.36	59.9	1.6	40.6	1-3/16"	0.37	5	25
3/8"	3STF3-SS	3/8" - 18 NPTF	316 stainless	293.54	2.36	59.9	1.6	40.6	1-3/16"	0.38	5	25
3/8"	3STBF3	3/8" - 19 BSPP	steel	82.12	2.36	59.9	1.6	40.6	1-3/16"	0.37	5	25
3/8"	3STBF3-SS	3/8" - 19 BSPP	316 stainless	293.54	2.36	59.9	1.6	40.6	1-3/16"	0.38	5	25
3/8"	3STF4	1/2" - 14 NPTF	steel	82.12	2.36	59.9	1.6	40.6	1-3/16"	0.36	5	25
3/8"	3STF4-SS	1/2" - 14 NPTF	316 stainless	293.54	2.36	59.9	1.6	40.6	1-3/16"	0.37	5	25
3/8"	3STBF4	1/2" - 14 BSPP	steel	82.12	2.36	59.9	1.6	40.6	1-3/16"	0.36	5	25
3/8"	3STBF4-SS	1/2" - 14 BSPP	316 stainless	293.54	2.36	59.9	1.6	40.6	1-3/16"	0.37	5	25
1/2"	4STF4	1/2" - 14 NPTF	steel	100.45	2.77	70.4	1.98	50.3	1-1/2"	0.47	-	20
1/2"	4STF4-SS	1/2" - 14 NPTF	316 stainless	384.51	2.77	70.4	1.98	50.3	1-1/2"	0.49	-	20
1/2"	4STBF4	1/2" - 14 BSPP	steel	100.45	2.77	70.4	1.98	50.3	1-1/2"	0.47	-	20
1/2"	4STBF4-SS	1/2" - 14 BSPP	316 stainless	384.51	2.77	70.4	1.98	50.3	1-1/2"	0.49	-	20
1/2"	4STOF4	3/4" - 16 ORB	steel	105.03	2.77	70.4	1.98	50.3	1-1/2"	0.49	-	20
3/4"	6STF6	3/4" - 14 NPTF	steel	139.77	3.03	77.0	2.35	59.7	1-3/4"	1.98	-	10
3/4"	6STF6-SS	3/4" - 14 NPTF	316 stainless	668.69	3.03	77.0	2.35	59.7	1-3/4"	2.05	-	10
3/4"	6STBF6	3/4" - 14 BSPP	steel	139.77	3.03	77.0	2.351	59.7	1-3/4"	1.98	-	10
3/4"	6STBF6-SS	3/4" - 14 BSPP	316 stainless	668.69	3.03	77.0	2.35	59.7	1-3/4"	2.05	-	10
3/4"	6STOF6	1-1/16" - 12 ORB	steel	151.92	3.03	77.0	2.35	59.7	1-3/4"	1.89	-	10
1"	8STF8	1" - 11 1/2 NPTF	steel	252.80	3.33	84.6	2.73	69.3	2"	2.78	-	5
1"	8STF8-SS	1" - 11 1/2 NPTF	316 stainless	1052.58	3.33	84.6	1.55	39.3	2"	2.83	-	5
1"	8STBF8	1" - 11 BSPP	steel	252.80	3.33	84.6	2.73	69.3	2"	2.78	-	5
1"	8STBF8-SS	1" - 11 BSPP	316 stainless	1052.58	3.33	84.6	2.73	69.3	2"	2.83	-	5
1"	8STOF8	1-5/16" - 12 ORB	steel	278.40	3.33	84.6	2.73	69.3	2"	2.71	-	5
1"	8STF10	1-1/4" - 11 1/2 NPTF	steel	295.34	3.67	93.2	2.73	69.3	2"	2.84	-	5
1"	8STF10-SS	1-1/4" - 11 1/2 NPTF	316 stainless	1263.10	3.67	93.2	2.73	69.3	2"	2.90	-	5
1"	8STBF10	1-1/4" - 11 BSPP	steel	295.34	3.67	93.2	2.73	69.3	2"	2.84	-	5
1"	8STBF10-SS	1-1/4" - 11 BSPP	316 stainless	1263.10	3.67	93.2	2.73	69.3	2"	2.90	-	5
1"	8STOF10	1-5/8" - 12 ORB	steel	303.67	3.67	93.2	2.73	69.3	2"	2.79	-	5

## ST-Series Hydraulic Couplings

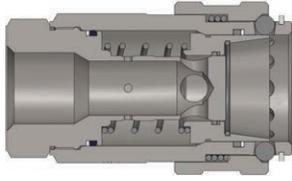

Body Size	ST-Series Snap-Tite 71-Series 'Old Style' Interchange Coupler (Female Threads)											
	Part Detail			List Price	Length		Maximum OD		Hex Inch	Weight Lb	Package Qty	
	Part Number	Threads	Material		Inch	mm	Inch	mm			Bag	Box
1"	8STF8-V2	1" - 11 1/2 NPTF	steel	<b>\$274.08</b>	4.55	115.6	2.74	69.6	2"	2.83	-	5
1"	8STBF8-V2	1" - 11 BSPP	steel	<b>274.08</b>	4.55	115.6	2.74	69.6	2"	2.84	-	5
1"	8STF10-V2	1-1/4" - 11 1/2 NPTF	steel	<b>303.69</b>	4.90	124.5	2.74	69.6	2"	2.87	-	5
2"	16STF12	1-1/2" - 11 1/2 NPTF	steel	<b>1397.71</b>	6.20	157.5	4.47	113.5	3.78"	9.07	-	1
2"	16STBF12	1-1/2" - 11 BSPP	steel	<b>1397.71</b>	6.20	157.5	4.47	113.5	3.78"	9.07	-	1
2"	16STOF12	1-7/8" - 12 ORB	steel	<b>1458.47</b>	6.20	157.5	4.47	113.5	3.78"	8.96	-	1
2"	16STF16	2" - 11 1/2 NPTF	steel	<b>1397.71</b>	6.20	157.5	4.47	113.5	3.78"	8.74	-	1
2"	16STF16-SS	2" - 11 1/2 NPTF	316 stainless	<b>2352.82</b>	6.20	157.5	4.47	113.5	3.78"	8.74	-	1
2"	16STBF16	2" - 11 BSPP	steel	<b>1397.71</b>	6.20	157.5	4.47	113.5	3.78"	8.74	-	1
2"	16STOF16	2-1/2" - 12 ORB	steel	<b>1458.47</b>	6.20	157.5	4.47	113.5	3.78"	8.63	-	1

### ST Series Profiles

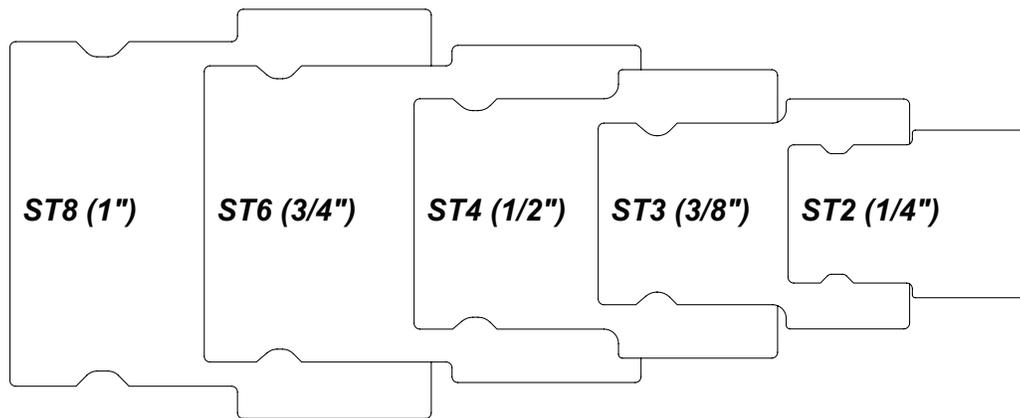

Note: Minimum burst pressure ratings were established under laboratory conditions using a Static Burst Unit (SBU). For high impulse applications and to meet Det Norske Veritas (DNV) compliance, the burst pressure must be divided by four (4) to ensure a 4:1 safety factor during system operation.

## ST-Series Hydraulic Couplings

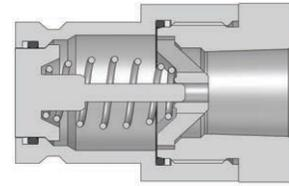

Body Size	ST-Series Snap-Tite 71-Series Interchange Nipple (Female Threads)											
	Part Detail			List Price	Length		Maximum OD		Hex Inch	Weight Lb	Package Qty	
	Part Number	Threads	Material		Inch	mm	Inch	mm			Bag	Box
1/4"	ST2F2	1/4" - 18 NPTF	steel	<b>\$51.94</b>	1.84	46.7	0.90	22.9	13/16"	0.16	5	25
1/4"	ST2F2-SS	1/4" - 18 NPTF	316 stainless	<b>118.83</b>	1.84	46.7	0.90	22.9	13/16"	0.16	5	25
1/4"	ST2BF2	1/4" - 19 BSPP	steel	<b>51.94</b>	1.84	46.7	0.90	22.9	13/16"	0.16	5	25
1/4"	ST2BF2-SS	1/4" - 19 BSPP	316 stainless	<b>118.83</b>	1.84	46.7	0.90	22.9	13/16"	0.16	5	25
3/8"	ST3F2	1/4" - 18 NPTF	steel	<b>43.63</b>	2.32	58.9	1.48	37.6	1"	0.29	5	25
3/8"	ST3F3	3/8" - 18 NPTF	steel	<b>43.63</b>	2.32	58.9	1.48	37.6	1"	0.26	5	25
3/8"	ST3F3-SS	3/8" - 18 NPTF	316 stainless	<b>124.67</b>	2.32	58.9	1.48	37.6	1"	0.26	5	25
3/8"	ST3BF3	3/8" - 19 BSPP	steel	<b>43.63</b>	2.32	58.9	1.48	37.6	1"	0.26	5	25
3/8"	ST3BF3-SS	3/8" - 19 BSPP	316 stainless	<b>124.67</b>	2.32	58.9	1.48	37.6	1"	0.26	5	25
3/8"	ST3F4	1/2" - 14 NPTF	steel	<b>43.63</b>	2.32	58.9	1.48	37.6	1"	0.26	5	25
3/8"	ST3F4-SS	1/2" - 14 NPTF	316 stainless	<b>124.67</b>	2.32	58.9	1.48	37.6	1"	0.26	5	25
3/8"	ST3BF4	1/2" - 14 BSPP	steel	<b>43.63</b>	2.32	58.9	1.48	37.6	1"	0.26	5	25
3/8"	ST3BF4-SS	1/2" - 14 BSPP	316 stainless	<b>124.67</b>	2.32	58.9	1.48	37.6	1"	0.26	5	25
1/2"	ST4F4	1/2" - 14 NPTF	steel	<b>65.89</b>	2.37	60.2	1.65	41.9	1-1/2"	0.42	-	20
1/2"	ST4F4-SS	1/2" - 14 NPTF	316 stainless	<b>138.44</b>	2.37	60.2	1.65	41.9	1-1/2"	0.42	-	20
1/2"	ST4BF4	1/2" - 14 BSPP	steel	<b>65.89</b>	2.37	60.2	1.65	41.9	1-1/2"	0.42	-	20
1/2"	ST4BF4-SS	1/2" - 14 BSPP	316 stainless	<b>138.44</b>	2.37	60.2	1.65	41.9	1-1/2"	0.42	-	20
1/2"	ST4OF4	3/4" - 16 ORB	steel	<b>68.83</b>	2.37	60.2	1.65	41.9	1-1/2"	0.42	-	20
3/4"	ST6F6	3/4" - 14 NPTF	steel	<b>75.97</b>	2.96	75.2	1.92	48.8	1-3/4"	1.09	-	10
3/4"	ST6F6-SS	3/4" - 14 NPTF	316 stainless	<b>309.58</b>	2.96	75.2	1.92	48.8	1-3/4"	1.14	-	10
3/4"	ST6BF6	3/4" - 14 BSPP	steel	<b>75.97</b>	2.96	75.2	1.92	48.8	1-3/4"	1.09	-	10
3/4"	ST6BF6-SS	3/4" - 14 BSPP	316 stainless	<b>309.58</b>	2.96	75.2	1.92	48.8	1-3/4"	1.14	-	10
3/4"	ST6OF6	1-1/16" - 12 ORB	steel	<b>82.40</b>	2.96	75.2	1.92	48.8	1-3/4"	1.01	-	10
1"	ST8F8	1" - 11 1/2 NPTF	steel	<b>113.03</b>	3.22	81.8	2.10	53.3	1-7/8"	1.48	-	5
1"	ST8F8-SS	1" - 11 1/2 NPTF	316 stainless	<b>347.83</b>	3.22	81.8	2.10	53.3	1-7/8"	1.56	-	5
1"	ST8BF8	1" - 11 BSPP	steel	<b>113.03</b>	3.22	81.8	2.10	53.3	1-7/8"	1.48	-	5
1"	ST8BF8-SS	1" - 11 BSPP	316 stainless	<b>347.83</b>	3.22	81.8	2.10	53.3	1-7/8"	1.56	-	5
1"	ST8OF8	1-5/16" - 12 ORB	steel	<b>121.54</b>	3.22	81.8	2.10	53.3	1-7/8"	1.37	-	5
1"	ST8F10	1-1/4" - 11 1/2 NPTF	steel	<b>154.36</b>	3.48	88.4	2.20	55.9	2"	1.63	-	5
1"	ST8F10-SS	1-1/4" - 11 1/2 NPTF	316 stainless	<b>427.22</b>	3.48	88.4	2.20	55.9	2"	1.69	-	5
1"	ST8BF10	1-1/4" - 11 BSPP	steel	<b>154.36</b>	3.48	88.4	2.20	55.9	2"	1.63	-	5
1"	ST8BF10-SS	1-1/4" - 11 BSPP	316 stainless	<b>427.22</b>	3.48	88.4	2.20	55.9	2"	1.69	-	5
1"	ST8OF10	1-5/8" - 12 ORB	steel	<b>162.87</b>	3.48	88.4	2.20	55.9	2"	1.54	-	5

## ST-Series Hydraulic Couplings

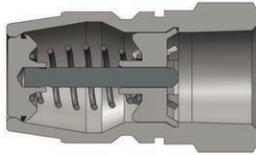

Body Size	ST-Series Snap-Tite 71-Series 'Old Style' Interchange Nipple (Female Threads)											
	Part Detail			List Price	Length		Maximum OD		Hex Inch	Weight Lb	Package Qty	
	Part Number	Threads	Material		Inch	mm	Inch	mm			Bag	Box
1"	ST8F8-V2	1" - 11 1/2 NPTF	steel	\$122.17	3.26	82.8	1.92	48.8	1-3/4"	1.53	-	5
1"	ST8BF8-V2	1" - 11 BSPP	steel	122.17	3.26	82.8	1.92	48.8	1-3/4"	1.48	-	5
1"	ST8F10-V2	1-1/4" - 11 1/2 NPTF	steel	136.33	3.5	88.9	1.98	50.3	2"	1.48	-	5
2"	ST16F12	1-1/2" - 11 1/2 NPTF	steel	751.12	4.50	114.3	3.48	88.4	3-1/4"	4.32	-	1
2"	ST16BF12	1-1/2" - 11 BSPP	steel	751.12	4.50	114.3	3.48	88.4	3-1/4"	4.32	-	1
2"	ST16OF12	1-7/8" - 12 ORB	steel	820.40	4.50	114.3	3.48	88.4	3-1/4"	4.21	-	1
2"	ST16F16	2" - 11 1/2 NPTF	steel	751.12	4.50	114.3	3.48	88.4	3-1/4"	4.16	-	1
2"	ST16F16-SS	2" - 11 1/2 NPTF	316 stainless	1609.83	4.50	114.3	3.48	88.4	3-1/4"	4.16	-	1
2"	ST16BF16	2" - 11 BSPP	steel	751.12	4.50	114.3	3.48	88.4	3-1/4"	4.16	-	1
2"	ST16OF16	2-1/2" - 12 ORB	steel	843.59	4.50	114.3	3.48	88.4	3-1/4"	4.05	-	1



Body Size	ST-Series Coupler Dust Plug						
	Part Detail			List Price	Weight Lb	Package Qty	
	Part Number	Lanyard	Body			Bag	Box
1/4"	2STDP-A	SS Bead Chain	aluminum	\$10.02	0.15	5	25
3/8"	3STDP-A	SS Bead Chain	aluminum	10.76	0.18	5	25
1/2"	4STDP-A	SS Bead Chain	aluminum	11.43	0.23	5	25
3/4"	6STDP-A	SS Bead Chain	aluminum	33.92	0.36	-	10
1"	8STDP-A	SS Bead Chain	aluminum	43.01	0.39	-	10
1"-V2	8STDP-A-V2	SS Bead Chain	aluminum	43.01	0.48	-	10
2"	16STDP-A	SS Bead Chain	aluminum	103.90	0.94	-	1



Body Size	ST-Series Nipple Dust Plug						
	Part Detail			List Price	Weight Lb	Package Qty	
	Part Number	Lanyard	Body			Bag	Box
1/4"	ST2DC-A	SS Bead Chain	aluminum	\$10.02	0.16	5	25
3/8"	ST3DC-A	SS Bead Chain	aluminum	10.62	0.19	5	25
1/2"	ST4DC-A	SS Bead Chain	aluminum	14.62	0.22	5	25
3/4"	ST6DC-A	SS Bead Chain	aluminum	29.26	0.26	-	10
1"	ST8DC-A	SS Bead Chain	aluminum	38.07	0.28	-	10
1-1/2"	ST8DC-A-V2	SS Bead Chain	aluminum	38.07	0.46	-	10
2"	ST16DC-A	SS Bead Chain	aluminum	113.11	0.76	-	1

## ST-Series Hydraulic Couplings

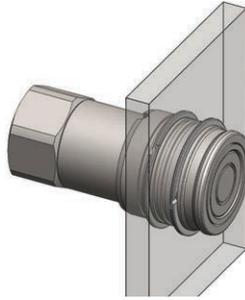

ST-Series Snap-Tite 71-Series Interchange Coupler Bulkhead Kits							
Body Size	Part Detail			List Price	Bulkhead Kit Contents	Package Qty	
	Part Number	Mounting Hole ID	Ring Material			Bag	Box
1/4"	2ST-BMK	1.250"	steel	<b>\$4.44</b>	Two 360° Retaining Rings	1	25
3/8"	3ST-BMK	1.625"	steel	<b>4.86</b>	Two 360° Retaining Rings	1	25
1/2"	4ST-BMK	2.000"	steel	<b>5.32</b>	Two 360° Retaining Rings	1	25
3/4"	6ST-BMK	2.375"	steel	<b>6.01</b>	Two 360° Retaining Rings	1	25

ST-Series Snap-Tite 71-Series Interchange Coupler Seal Kits							
Body Size	Part Detail			List Price	Seal Kit Contents	Package Qty	
	Part Number	Coupler Style	Seal Material			Bag	Box
1/4"	2ST-SKIT	all	Nitrile	<b>\$5.02</b>	Two Seals and Anti-Extrusion Rings	25	200
3/8"	3ST-SKIT	all	Nitrile	<b>5.64</b>	Two Seals and Anti-Extrusion Rings	25	200
1/2"	4ST-SKIT	all	Nitrile	<b>6.12</b>	Two Seals and Anti-Extrusion Rings	25	200
3/4"	6ST-SKIT	all	Nitrile	<b>6.55</b>	Two Seals and Anti-Extrusion Rings	25	200
1"	8ST-SKIT	all	Nitrile	<b>6.72</b>	Two Seals and Anti-Extrusion Rings	25	200
1"	8ST-SKIT-V2	all	Nitrile	<b>6.72</b>	Three Seals and Two Anti-Extrusion Rings	25	200
2"	16ST-SKIT	all	Nitrile	<b>7.91</b>	Three Seals and Two Anti-Extrusion Rings	10	100

ST-Series Snap-Tite 71-Series Interchange Nipple Seal Kits							
Body Size	Part Detail			List Price	Seal Kit Contents	Package Qty	
	Part Number	Coupler Style	Seal Material			Bag	Box
1/4"	ST2-SKIT	all	Nitrile	<b>\$4.69</b>	Valve O-Ring/Back-up and Adapter O-Ring	25	200
3/8"	ST3-SKIT	all	Nitrile	<b>5.36</b>	Valve O-Ring/Back-up and Adapter O-Ring	25	200
1/2"	ST4-SKIT	all	Nitrile	<b>5.72</b>	Valve O-Ring/Back-up and Adapter O-Ring	25	200
3/4"	ST6-SKIT	all	Nitrile	<b>6.17</b>	Valve O-Ring/Back-up and Adapter O-Ring	25	200
1"	ST8-SKIT	all	Nitrile	<b>6.37</b>	Valve O-Ring/Back-up and Adapter O-Ring	25	200
2"	ST16-SKIT	all	Nitrile	<b>7.64</b>	Main Valve Seal	25	200



# PD-Series Hydraulic Couplings

### Interchange Data:

- Interchangeable to ISO15171-1
- Parker PD-Series, Aeroquip FD90, Tomco Series DK

### Materials:

- Machined components are manufactured using solid steel bar stock.
- Stainless steel balls, retaining rings, and springs maximize corrosion resistance and extend service life.
- Steel nipples are machined from solid steel bar stock and hardened.
- Steel componentry is plated using ROHS Compliant Trivalent Chrome.

### Seal Components:

- Nitrile (Buna-N) seals are standard, providing a temperature range of -40°F to +250°F (-40°C to +121°C).
- PTFE anti-extrusion ring protects main coupler O-Ring from dynamic impulse pressure damage.

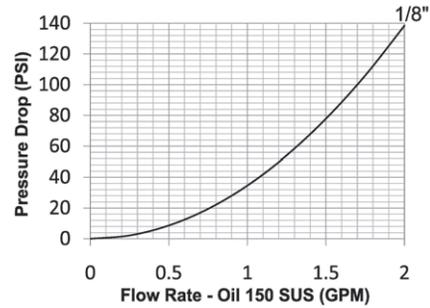

### Rated Pressure Chart:

Body Size	PD-Series ISO15171-1 Diagnostic Interchange							
	Steel Coupler/Plug Connected				Steel Plug Disconnected			
	Maximum Working		Burst		Maximum Working		Burst	
	PSI	Bar	PSI	Bar	PSI	Bar	PSI	Bar
1/8"	6,000	400	18,700	1,300	6,000	400	24,000	1,600

### Technical Specifications:

Body Size	Interchange Standards				Functional Parameters				
	U.S. Military	U.S. Government	International Standards	ANSI/NFPA Standards	Locking Ball Quantity	Air Inclusion	Fluid Loss	Vacuum Rating	Flow ΔP = 22 PSI
1/8"	-	-	ISO15171-1	SAE J1502	10	0.02	0.1	27.4	0.8

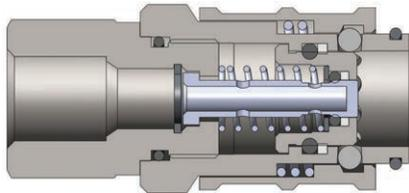

Body Size	PD-Series ISO15171-1 Diagnostic Coupler (Female Threads)											
	Part Detail			List Price	Length		Maximum OD		Hex mm	Weight Lb	Package Qty	
	Part Number	Threads	Material		Inch	mm	Inch	mm			Bag	Box
1/8"	1PDF1	1/8" - 27 NPT	steel	\$48.52	2.13	54.102	0.98	24.892	21	0.18	10	100
1/8"	1PDF2	1/4" - 18 NPT	steel	48.52	2.13	54.102	0.98	24.892	21	0.16	10	100

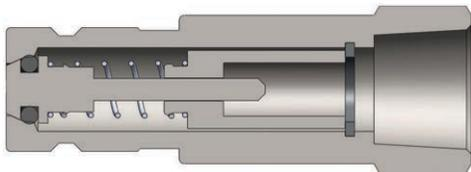

Body Size	PD-Series ISO15171-1 Diagnostic Nipple (Female Threads)											
	Part Detail			List Price	Length		Maximum OD		Hex mm	Weight Lb	Package Qty	
	Part Number	Threads	Material		Inch	mm	Inch	mm			Bag	Box
1/8"	PD1F1	1/8" - 27 NPT	steel	\$15.83	1.88	47.752	0.76	19.304	17	0.04	10	100
1/8"	PD1F2	1/4" - 18 NPT	steel	11.92	1.88	47.752	0.76	19.304	17	0.04	10	100

## PD-Series Hydraulic Couplings

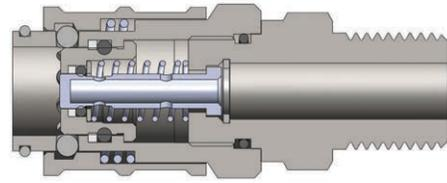

Body Size	PD-Series ISO15171-1 Diagnostic Coupler (Male Threads)											
	Part Detail			List Price	Length		Maximum OD		Hex mm	Weight Lb	Package Qty	
	Part Number	Threads	Material		Inch	mm	Inch	mm			Bag	Box
1/8"	1PDM2	1/4" - 18 NPT	steel	<b>\$48.52</b>	2.28	57.9	0.98	24.9	21	0.18	10	100

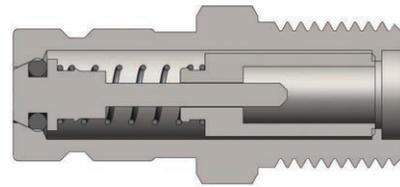

Body Size	PD-Series ISO15171-1 Diagnostic Nipple (Male Threads)											
	Part Detail			List Price	Length		Maximum OD		Hex mm	Weight Lb	Package Qty	
	Part Number	Threads	Material		Inch	mm	Inch	mm			Bag	Box
1/8"	PD1M1	1/8" - 27 NPT	steel	<b>\$13.11</b>	1.98	50.292	0.76	19.304	17	0.05	10	100
1/8"	PD1M2	1/4" - 18 NPT	steel	<b>11.92</b>	1.48	37.592	0.76	19.304	17	0.04	10	100

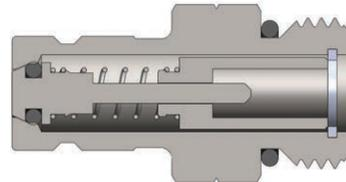

Body Size	PD-Series ISO15171-1 Diagnostic Nipple (Male ORB Threads)											
	Part Detail			List Price	Length		Maximum OD		Hex mm	Weight Lb	Package Qty	
	Part Number	Threads	Material		Inch	mm	Inch	mm			Bag	Box
1/8"	PD1OM2	7/16" - 20 ORB	steel	<b>\$12.81</b>	1.93	49.0	0.76	19.304	17	0.06	10	100
1/8"	PD1OM3	9/16" - 18 ORB	steel	<b>12.51</b>	1.48	37.592	0.76	19.304	17	0.06	10	100

Body Size	PD-Series Nipple Dust Cap											
	Part Detail			List Price					Hex mm	Weight Lb	Package Qty	
	Part Number	Material					Bag	Box				
1/8"	H1DC	Nitrile		<b>\$3.16</b>						5	50	

### PD Series Profile



# VEP-Series Hydraulic Couplings

## Interchange Data:

- Interchangeable with Stucchi VEP-P/VEP-HD Series, DNP PST4/FSI Series, Voswinkel FT Series, Parker FET-Series, and Holmbury HFT Series.

## Seal Components:

- Nipples have Nitrile-Energized PTFE valve seals, with a temperature range of -40°F to +250°F (-40°C to +121°C)
- 3/8" nipples have molded Polyurethane valve seals, with a temperature range of -65°F to +212°F (-54°C to +100°C)
- 1/4" to 3/4" valve stems have molded Acetal seals, with a temperature range of -65°F to +212°F (-54°C to +100°C)
- 1" to 2" valve stems have molded Polyurethane seals, with a temperature range of -65°F to +212°F (-54°C to +100°C)
- Ancillary coupler and nipple seals are Nitrile (Buna-N), with a temperature range of -40°F to +250°F (-40°C to +121°C)
- TPC-ET Anti-Extrusion ring protects main coupling valve seal from dynamic impulse pressure damage

## Materials:

- Machined components are manufactured using solid steel bar stock
- Stainless steel retaining rings and springs maximize corrosion resistance and extend service life
- Steel componentry is plated using ROHS Compliant Zinc Nickel for superior corrosion resistance.

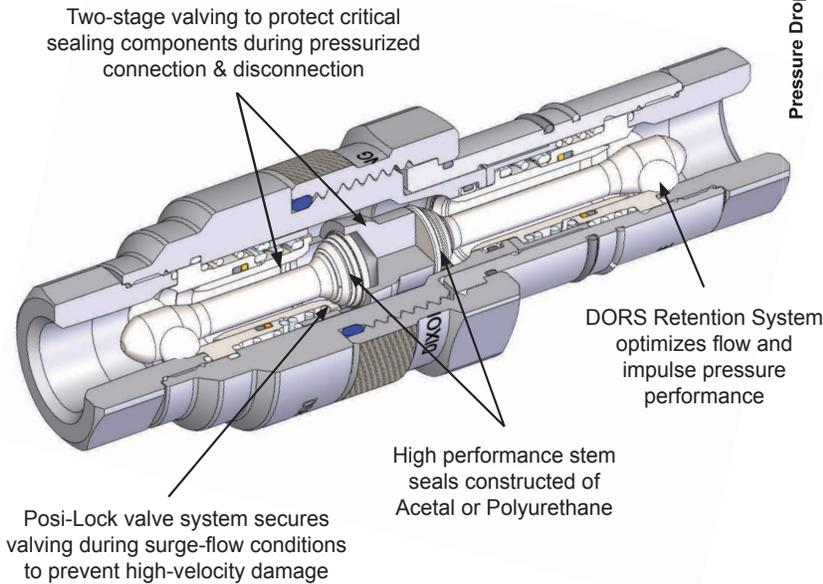
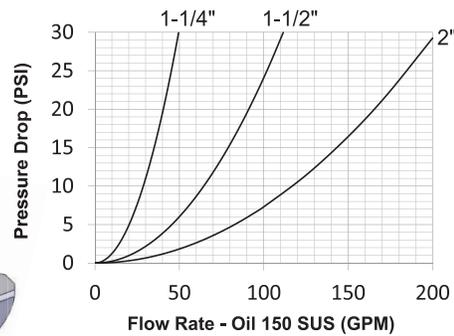
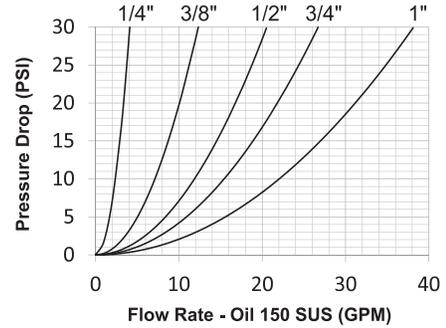

## Rated Pressure Chart:

VEP-Series Interchange																
Body Size	Pressure Rating				Burst Pressure						Max. Pressure Connect <sup>3</sup>		Max. Pressure Disconnect <sup>3</sup>		Rated Flow ΔP=21.75psi	
	ISO Working <sup>1</sup>		Max. Impulse <sup>2</sup>		Connected		Coupler		Plug		psi	MPa	psi	MPa	GPM	L/min
	psi	MPa	psi	MPa	psi	MPa	psi	MPa	psi	MPa	psi	MPa	psi	MPa		
1/4"	6,000	40	9,000	62	24,000	165	22,000	152	22,000	152	5,500	38	5,500	38	3.5	13
3/8"	5,500	38	8,000	55	22,000	152	18,000	124	20,000	138	4,500	31	4,500	31	10.5	40
1/2"	5,500	38	8,000	55	22,000	152	18,000	124	20,000	138	4,500	31	4,500	31	17.5	66
3/4"	5,500	38	8,000	55	22,000	152	18,000	124	20,000	138	4,500	31	4,500	31	22.7	85
1"	5,500	38	7,500	52	22,000	152	14,500	100	20,000	138	3,625	25	3,625	25	32.5	123
1-1/4"	5,000	35	7,000	48	20,000	138	14,500	100	16,000	110	3,625	25	3,625	25	46.4	174
1-1/2"	4,500	31	5,800	40	18,000	124	12,000	83	14,500	100	3,000	21	3,000	21	95.0	360
2"	4,000	28	5,000	35	18,000	124	12,000	83	14,500	100	3,000	21	3,000	21	172.5	653

<sup>1</sup> Couplings Impulse tested in accordance with ISO7241-2 for 1,000,000 cycles connected and 100,000 cycles disconnected at 133% of ISO Working Pressure.

<sup>2</sup> Couplings Impulse tested in accordance with ISO7241-2 for 100,000 cycles connected and disconnected at Maximum Impulse pressure listed

<sup>3</sup> System temperature for Maximum Connect/Disconnect Pressure must not exceed 150°F (65°C)

# VEP-Series Hydraulic Couplings

## How to Connect & Disconnect the VEP-Series Coupling

1. Prior to connecting, thoroughly clean all mating surfaces and threads on both halves, then pull the coupler sleeve forward.
2. To initiate the connection, align the coupler and plug, pushing/turning the coupler sleeve towards the plug while engaging the threads. Keep the mating halves aligned during the connection process.
3. Allow the threads to pull the coupler onto the plug, do not push the coupler onto the plug.
4. The first phase of the connection should be threaded by hand, without the use of tools. Please note the connection sleeve may seize when dirt and debris accumulate in the threads - wipe away debris with a cloth, compressed air, or a brush.
5. The second phase of the connection may require a wrench if the pressure is higher than anticipated.
6. Continue to thread the coupler sleeve onto the plug until the end of the sleeve meets the plug body
7. To disconnect, use a wrench to break the coupler sleeve free and keep the mating halves aligned during the disconnection process.

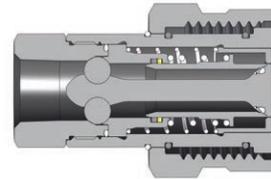
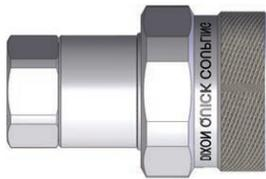

Body Size	VEP-Series Interchange Coupler (Female Threads)									
	Part Detail		List Price	Length		Maximum OD		Hex mm	Weight Lb	Box Qty
	Part Number	Threads		Inch	mm	Inch	mm			
1/4"	2VEPF2	1/4" - 18 NPTF	\$108.77	2.14	54.4	1.49	37.8	22	0.49	20
1/4"	2VEPBF2	1/4" - 19 BSPP	108.77	2.14	54.4	1.49	37.8	22	0.49	20
1/4"	2VEPOF3	9/16" - 18 ORB	119.65	2.14	54.4	1.49	37.8	22	0.49	20
3/8"	3VEPF3	3/8" - 18 NPTF	121.80	2.55	64.8	1.62	41.1	25	0.63	20
3/8"	3VEPBF3	3/8" - 19 BSPP	123.36	2.55	64.8	1.62	41.1	25	0.63	20
3/8"	3VEPOF4	3/4" - 16 ORB	126.54	2.77	70.4	1.62	41.1	25	0.67	20
3/8"	3VEPF4	1/2" - 14 NPTF	124.53	2.77	70.4	1.62	41.1	28	0.66	20
3/8"	3VEPBF4	1/2" - 14 BSPP	123.36	2.77	70.4	1.62	41.1	28	0.66	20
1/2"	4VEPF4	1/2" - 14 NPTF	158.55	3.08	78.2	1.98	50.3	30	1.36	15
1/2"	4VEPBF4	1/2" - 14 BSPP	162.99	3.08	78.2	1.98	50.3	30	1.36	15
1/2"	4VEPOF4	3/4" - 16 ORB	164.69	3.08	78.2	1.98	50.3	30	1.38	15
1/2"	4VEPOF5	7/8" - 14 ORB	164.69	3.18	80.8	1.98	50.3	32	1.43	15
1/2"	4VEPF6	3/4" - 14 NPTF	162.65	3.38	85.9	1.98	50.3	38	1.57	15
1/2"	4VEPBF6	3/4" - 14 BSPP	162.99	3.38	85.9	1.98	50.3	38	1.57	15
1/2"	4VEPOF6	1-1/16" - 12 ORB	164.69	3.58	90.9	1.98	50.3	38	1.59	15
3/4"	6VEPF6	3/4" - 14 NPTF	206.17	3.37	85.6	2.19	55.6	38	1.70	1
3/4"	6VEPBF6	3/4" - 14 BSPP	211.11	3.37	85.6	2.19	55.6	38	1.70	1
3/4"	6VEPOF6	1-1/16" - 12 ORB	206.17	3.37	85.6	2.19	55.6	38	1.70	1
1"	8VEPF8	1" - 11 1/2 NPTF	261.27	3.89	98.8	2.46	62.5	44	2.44	1
1"	8VEPBF8	1" - 11 BSPP	265.86	3.89	98.8	2.46	62.5	44	2.44	1
1"	8VEPOF8	1-5/16" - 12 ORB	263.30	3.89	98.8	2.46	62.5	44	2.44	1
1-1/4"	10VEPF10	1-1/4" - 11 1/2 NPTF	302.10	4.40	111.8	2.70	68.6	55	3.76	1
1-1/4"	10VEPBF10	1-1/4" - 11 BSPP	316.90	4.40	111.8	2.70	68.6	55	3.76	1
1-1/4"	10VEPOF10	1-5/8" - 12 ORB	305.27	4.40	111.8	2.70	68.6	55	3.75	1
1-1/2"	12VEPF12	1-1/2" - 11 1/2 NPTF	866.42	5.28	134.1	3.74	95.0	63	9.09	1
1-1/2"	12VEPBF12	1-1/2" - 11 BSPP	919.16	5.28	134.1	3.74	95.0	63	9.09	1
1-1/2"	12VEPOF12	1-7/8" - 12 ORB	885.01	5.28	134.1	3.74	95.0	63	9.10	1
2"	16VEPF16	2" - 11 1/2 NPTF	2864.19	9.42	239.3	7.39	187.7	89	33.56	1
2"	16VEPBF16	2" - 11 BSPP	3399.57	9.42	239.3	7.39	187.7	89	33.56	1
2"	16VEPOF16	2" - 12 ORB	2864.19	9.42	239.3	7.39	187.7	89	33.56	1

## VEP-Series Hydraulic Couplings

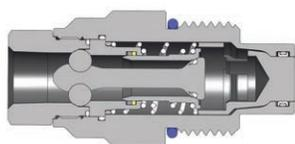

Body Size	VEP-Series Interchange Nipples (Female Threads)									
	Part Detail		List Price	Length		Maximum OD		Hex mm	Weight Lb	Box Qty
	Part Number	Threads		Inch	mm	Inch	mm			
1/4"	VEP2F2	1/4" - 18 NPTF	\$102.09	2.67	67.8	1.35	34.3	22	0.53	20
1/4"	VEP2BF2	1/4"-19 BSPP	102.09	2.67	67.8	1.35	34.3	22	0.53	20
1/4"	VEP2OF3	9/16" - 18 ORB	112.30	2.67	67.8	1.35	34.3	22	0.53	20
3/8"	VEP3F3	3/8" - 18 NPTF	138.15	3.28	83.3	1.48	37.6	25	0.76	20
3/8"	VEP3BF3	3/8" - 19 BSPP	141.26	3.28	83.3	1.48	37.6	25	0.76	20
3/8"	VEP3OF4	3/4" - 16 ORB	142.92	3.50	88.9	1.48	37.6	25	0.79	20
3/8"	VEP3F4	1/2" - 14 NPTF	140.86	3.50	88.9	1.48	37.6	28	0.78	20
3/8"	VEP3BF4	1/2" - 14 BSPP	141.26	3.50	88.9	1.48	37.6	28	0.78	20
1/2"	VEP4F4	1/2" - 14 NPTF	158.55	3.87	98.3	1.86	47.2	30	1.30	10
1/2"	VEP4BF4	1/2" - 14 BSPP	162.99	3.87	98.3	1.86	47.2	30	1.30	10
1/2"	VEP4OF4	3/4" - 16 ORB	164.69	3.87	98.3	1.86	47.2	30	1.30	10
1/2"	VEP4OF5	7/8" - 14 ORB	164.69	3.97	100.8	1.86	47.2	32	1.35	10
1/2"	VEP4F6	3/4" - 14 NPTF	162.65	4.07	103.4	1.86	47.2	38	1.49	10
1/2"	VEP4BF6	3/4" - 14 BSPP	162.99	4.07	103.4	1.86	47.2	38	1.49	10
1/2"	VEP4OF6	1-1/16" - 12 ORB	164.69	4.27	108.5	1.86	47.2	38	1.51	10
3/4"	VEP6F6	3/4" - 14 NPTF	185.76	4.12	104.6	1.98	50.3	38	1.84	1
3/4"	VEP6BF6	3/4" - 14 BSPP	190.70	4.12	104.6	1.98	50.3	38	1.84	1
3/4"	VEP6OF6	1-1/16" - 12 ORB	185.76	4.12	104.6	1.98	50.3	38	1.84	1
1"	VEP8F8	1" - 11 1/2 NPTF	214.34	4.95	125.7	2.20	55.9	44	2.65	1
1"	VEP8BF8	1" - 11 BSPP	221.73	4.95	125.7	2.20	55.9	44	2.65	1
1"	VEP8OF8	1-5/16" - 12 ORB	216.35	4.95	125.7	2.20	55.9	44	2.65	1
1-1/4"	VEP10F10	1-1/4" - 11 1/2 NPTF	302.10	5.43	137.9	2.73	69.3	55	3.18	1
1-1/4"	VEP10BF10	1-1/4" - 11 BSPP	316.90	5.43	137.9	2.73	69.3	55	3.18	1
1-1/4"	VEP10OF10	1-5/8" - 12 ORB	305.27	5.43	137.9	2.73	69.3	55	3.17	1
1-1/2"	VEP12F12	1-1/2" - 11 1/2 NPTF	828.15	6.63	168.4	3.74	95.0	63	9.02	1
1-1/2"	VEP12BF12	1-1/2" - 11 BSPP	877.85	6.63	168.4	3.74	95.0	63	9.02	1
1-1/2"	VEP12OF12	1-7/8" - 12 ORB	847.80	6.63	168.4	3.74	95.0	63	9.03	1
2"	VEP16F16	2" - 11 1/2 NPTF	2129.80	11.08	281.4	5.70	144.8	89	28.35	1
2"	VEP16BF16	2" - 11 BSPP	2257.11	11.08	281.4	5.70	144.8	89	28.35	1
2"	VEP16OF16	2" - 12 ORB	2129.80	11.08	281.4	5.70	144.8	89	28.35	1

Body Size	VEP-Series Rigid Dust Plug				
	Part Number	List Price	Weight Lb	Package Qty	
				Bag	Box
1/4"	2VEPDP-A	\$27.01	0.06	5	50
3/8"	3VEPDP-A	31.03	0.13	5	50
1/2"	4VEPDP-A	48.55	0.13	5	25
3/4"	6VEPDP-A	51.29	0.19	5	25
1"	8VEPDP-A	52.62	0.31	-	10
1-1/4"	10VEPDP-A	53.98	0.38	-	10
1-1/2"	12VEPDP-A	134.90	1.00	-	5
2"	16VEPDP-A	197.61	3.80	-	1

Body Size	VEP-Series Rigid Dust Cap				
	Part Number	List Price	Weight Lb	Package Qty	
				Bag	Box
1/4"	VEP2DC-A	\$28.34	0.06	5	50
3/8"	VEP3DC-A	36.42	0.13	5	50
1/2"	VEP4DC-A	51.29	0.16	5	50
3/4"	VEP6DC-A	53.98	0.25	5	25
1"	VEP8DC-A	59.36	0.38	-	10
1-1/4"	VEP10DC-A	56.66	0.63	-	10
1-1/2"	VEP12DC-A	172.68	1.50	-	5
2"	VEP16DC-A	262.71	4.00	-	1



VEP Series dust caps and plugs are aluminum with a stainless steel bead chain

# W-Series Hydraulic Couplings

## Interchange Data:

- Aeroquip 5100-Series, Parker 6100-Series
- Snap-Tite 78-Series, Faster Series-FB, Safeway S51-Series

## Materials:

- Machined components are manufactured using solid steel and brass bar stock.
- Stainless steel retaining rings, and springs maximize corrosion resistance and extend service life.
- Steel componentry is plated using ROHS Compliant Trivalent Chrome.
- Rugged steel wing nut for threaded connect and disconnect operation.
- For steel models, coupler valve sleeve and nipple valve are constructed of brass.

## Seal Components:

- Nitrile (Buna-N) seals are standard, providing a temperature range of -40°F to +250°F (-40°C to +121°C).
- Couplings have a TPC-ET back-up ring on the valve sleeve to extend service life.
- Main coupler valve has a bonded face-seal to improve seal integrity during pressurized connection/disconnection.
- Nipple valve seal is crimped to improve seal integrity and prolong service life.
- External O-Ring on plug indicates full connection and acts as a contamination shield in connected mode.
- Redundant O-Ring on the coupler body will engage nipple for secondary sealing support.

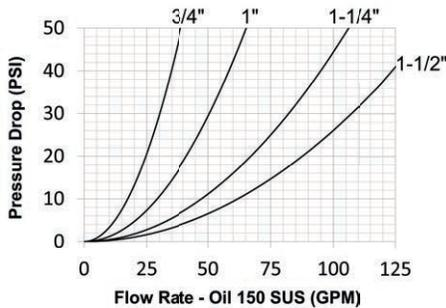

## Rated Pressure Chart:

Body Size	W-Series Wingstyle Interchange (Connected)			
	Coupler/Plug			
	Maximum Working		Burst	
	PSI	Bar	PSI	Bar
3/4"	3,000	207	13,000	897
1"	4,000	276	16,000	1,103
1-1/4"	3,000	207	12,000	828
1-1/2"	2,500	172	10,000	690

## Technical Specifications:

Body Size	Interchange Standards				Functional Parameters				
	U.S. Military	U.S. Government	International Standards	ANSI/NFPA Standards	Locking Mechanism	Air Inclusion	Fluid Loss	Vacuum Inch HG	Flow $\Delta P = 32$ PSI
3/4"	-	-	-	-	Threaded	0.34cc	0.26cc	27.4	31 GPM
1"	-	-	-	-	Threaded	0.50cc	0.35cc	27.4	52 GPM
1-1/4"	-	-	-	-	Threaded	0.68cc	0.70cc	27.4	85 GPM
1-1/2"	-	-	-	-	Threaded	0.60cc	0.94cc	27.4	110 GPM

\*\*Impulse Testing conducted in accordance with ISO7241-2 at 133% of Working Pressure for 1,000,000 cycles both connected and disconnected.

Although the wingstyle couplings are able to connect and disconnect while under pressure, it is recommended that hydraulic power supply be de-energized during connection to ensure operator safety. If it is not possible to de-energize the circuit, operators must be aware of their surroundings to ensure that an attachment or tool does not put them at risk, once hydraulic power is applied during the connection process.



W-Series couplings are not recommended for continuous hydraulic impulse applications at rated pressures.

# W-Series Hydraulic Couplings

2014  
**NEW**

## Wingstyle Socket Features

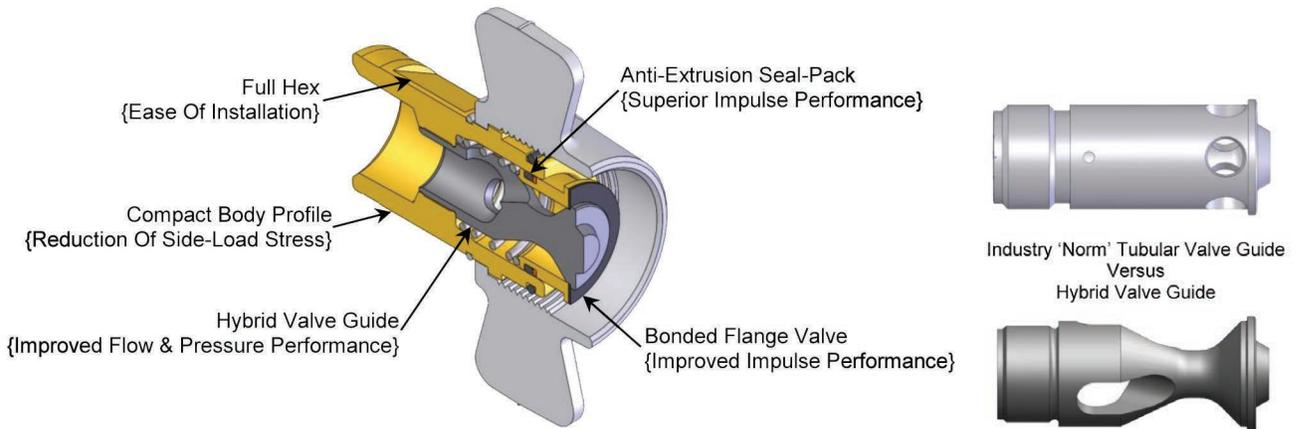

## Wingstyle Plug Features

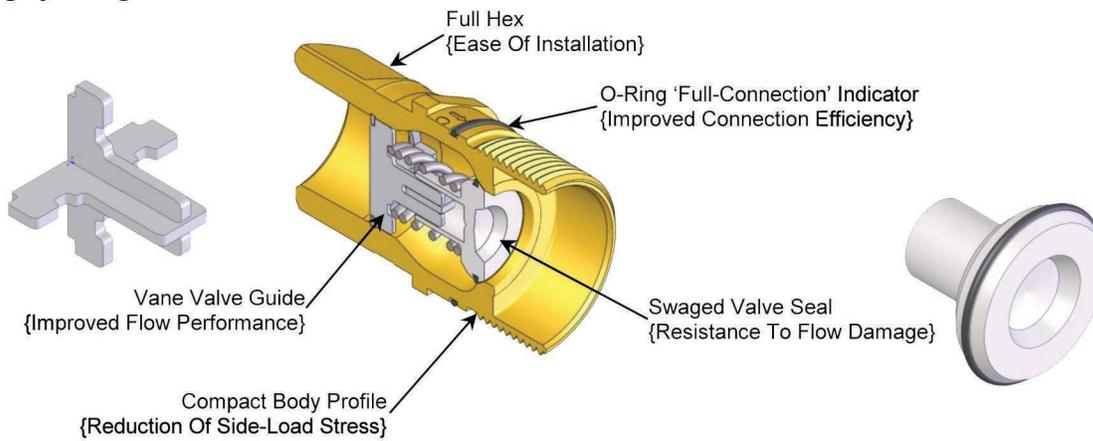

## W-Series Hydraulic Couplings

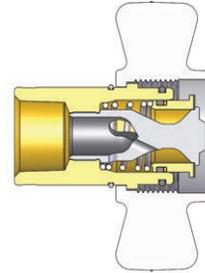

Body Size	W-Series Wingstyle Interchange Coupler (Female Threads)											
	Part Detail			List Price	Length		Maximum OD		Flats Inch	Weight Lb	Package Qty	
	Part Number	Threads	Material		Inch	mm	Inch	mm			Bag	Box
3/4"	6WF4-B	1/2" - 14 NPTF	brass	<b>\$79.57</b>	2.73	69.3	4.09	103.9	1-5/32"	1.20	-	10
3/4"	6WBF4-B	1/2" - 14 BSPP	brass	<b>74.26</b>	2.73	69.3	4.09	103.9	1-5/32"	1.20	-	10
3/4"	6WF6-B	3/4" - 14 NPTF	brass	<b>79.57</b>	2.73	69.3	4.09	103.9	1-5/32"	1.20	-	10
3/4"	6WBF6-B	3/4" - 14 BSPP	brass	<b>95.48</b>	2.73	69.3	4.09	103.9	1-5/32"	1.20	-	10
1"	8WF8-B	1" - 11 1/2 NPTF	brass	<b>97.60</b>	3.33	84.6	4.49	114.0	1-15/32"	1.90	-	10
1"	8WF8	1" - 11 1/2 NPTF	steel	<b>100.79</b>	3.33	84.6	4.49	114.0	1-15/32"	1.95	-	10
1"	8WBF8-B	1" - 11 BSPP	brass	<b>97.60</b>	3.33	84.6	4.49	114.0	1-15/32"	1.90	-	10
1-1/4"	10WF10-B	1-1/4" - 11 1/2 NPTF	brass	<b>178.23</b>	3.64	92.5	5.27	133.9	1-25/32"	3.00	-	5
1-1/4"	10WBF10-B	1-1/4" - 11 BSPP	brass	<b>188.49</b>	3.64	92.5	5.27	133.9	1-25/32"	3.00	-	5
1-1/2"	12WF12-B	1-1/2" - 11 1/2 NPTF	brass	<b>212.18</b>	3.67	93.2	5.35	135.9	2-7/64"	3.60	-	5
1-1/2"	12WBF12-B	1-1/2" - 11 BSPP	brass	<b>228.09</b>	4.08	103.6	5.35	135.9	2-7/64"	3.60	-	5

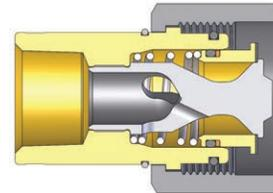
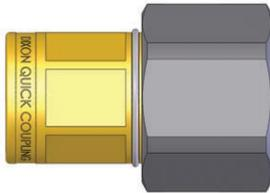

Body Size	W-Series Wingstyle Interchange Hex-Nut Coupler (Female Threads)											
	Part Detail			List Price	Length		Maximum OD		Flats Inch	Weight Lb	Package Qty	
	Part Number	Threads	Material		Inch	mm	Inch	mm			Bag	Box
3/4"	6WF4-B-HN	1/2" - 14 NPTF	brass	<b>\$79.57</b>	2.73	69.3	1.92	48.8	1-5/32"	1.05	-	10
3/4"	6WBF4-B-HN	1/2" - 14 BSPP	brass	<b>95.48</b>	2.73	69.3	1.92	48.8	1-5/32"	1.05	-	10
3/4"	6WF6-B-HN	3/4" - 14 NPTF	brass	<b>79.57</b>	2.73	69.3	1.92	48.8	1-5/32"	1.05	-	10
3/4"	6WBF6-B-HN	3/4" - 14 BSPP	brass	<b>95.48</b>	2.73	69.3	1.92	48.8	1-5/32"	1.05	-	10
1"	8WF8-B-HN	1" - 11 1/2 NPTF	brass	<b>97.60</b>	3.33	84.6	2.33	59.2	1-15/32"	1.70	-	10
1"	8WF8-HN	1" - 11 1/2 NPTF	steel	<b>113.52</b>	3.33	84.6	2.33	59.2	1-15/32"	1.75	-	10
1"	8WBF8-B-HN	1" - 11 BSPP	brass	<b>113.52</b>	3.33	84.6	2.33	59.2	1-15/32"	1.70	-	10
1-1/4"	10WF10-B-HN	1-1/4" - 11 1/2 NPTF	brass	<b>178.23</b>	3.64	92.5	2.75	69.9	1-25/32"	2.70	-	5
1-1/4"	10WBF10-B-HN	1-1/4" - 11 BSPP	brass	<b>188.49</b>	3.64	92.5	2.75	69.9	1-25/32"	2.70	-	5
1-1/2"	12WF12-B-HN	1-1/2" - 11 1/2 NPTF	brass	<b>212.18</b>	3.67	93.2	3.01	76.5	2-7/64"	3.15	-	5
1-1/2"	12WBF12-B-HN	1-1/2" - 11 BSPP	brass	<b>228.09</b>	3.67	93.2	3.01	76.5	2-7/64"	3.15	-	5



## W-Series Hydraulic Couplings

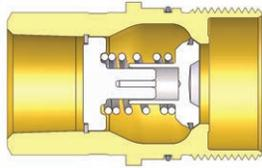

Body Size	W-Series Wingstyle Interchange Nipple (Female Threads)											
	Part Detail			List Price	Length		Maximum OD		Hex Inch	Weight Lb	Package Qty	
	Part Number	Threads	Material		Inch	mm	Inch	mm			Bag	Box
3/4"	W6F4-B	1/2" - 14 NPTF	brass	\$56.23	2.85	72.4	1.75	44.5	1-5/16"	0.82	-	10
3/4"	W6BF4-B	1/2" - 14 BSPP	brass	72.14	2.85	72.4	1.75	44.5	1-5/16"	0.82	-	10
3/4"	W6F6-B	3/4" - 14 NPTF	brass	56.23	2.85	72.4	1.75	44.5	1-5/16"	0.79	-	10
3/4"	W6BF6-B	3/4" - 14 BSPP	brass	72.14	2.85	72.4	1.75	44.5	1-5/16"	0.79	-	10
1"	W8F8-B	1" - 11 1/2 NPTF	brass	60.47	3.15	80.0	2.00	50.8	1-9/16"	1.10	-	10
1"	W8F8	1" - 11 1/2 NPTF	steel	63.65	3.15	80.0	2.00	50.8	1-9/16"	1.10	-	10
1"	W8BF8-B	1" - 11 BSPP	brass	76.38	3.15	80.0	2.00	50.8	1-9/16"	1.10	-	10
1-1/4"	W10F10-B	1-1/4" - 11 1/2 NPTF	brass	125.19	3.39	86.1	2.37	60.2	1-15/16"	1.40	-	5
1-1/4"	W10BF10-B	1-1/4" - 11 BSPP	brass	141.10	3.39	86.1	2.37	60.2	1-15/16"	1.40	-	5
1-1/2"	W12F12-B	1-1/2" - 11 1/2 NPTF	brass	212.18	3.74	95.0	2.73	69.3	2-1/4"	2.26	-	5
1-1/2"	W12BF12-B	1-1/2" - 11 BSPP	brass	228.09	3.74	95.0	2.73	69.3	2-1/4"	2.26	-	5



nipple not included with flange

Body Size	W-Series Wingstyle Interchange Nipple Mounting Flange						
	Part Detail			List Price	Weight Lb	Package Qty	
	Part Number	Bolt Hole Size	Material			Bag	Box
3/4"	W6-BMF	0.201"	steel	\$4.77	0.07	5	50
1"	W8-BMF	0.201"	steel	6.37	0.07	5	50
1-1/4"	W10-BMF	0.201"	steel	8.49	0.29	5	50
1-1/2"	W12-BMF	0.201"	steel	10.61	0.76	5	50

## W-Series Hydraulic Couplings

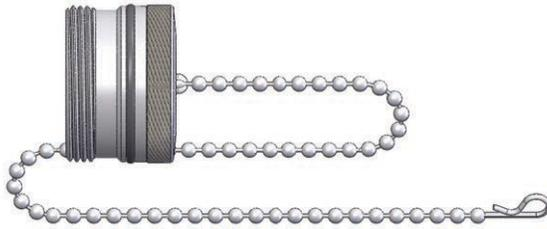

Body Size	W-Series Wingstyle Interchange Coupler Rigid Dust Plug						
	Part Detail			List Price	Weight Lb	Package Qty	
	Part Number	Lanyard	Body			Bag	Box
3/4"	6WDP	SS Bead Chain	steel	<b>\$18.23</b>	0.31	10	50
1"	8WDP	SS Bead Chain	steel	<b>20.09</b>	0.48	10	50
1-1/4"	10WDP	SS Bead Chain	steel	<b>28.84</b>	0.61	5	25
1-1/2"	12WDP	SS Bead Chain	steel	<b>51.50</b>	1.20	-	20



Body Size	W-Series Wingstyle Interchange Nipple Rigid Dust Cap						
	Part Detail			List Price	Weight Lb	Package Qty	
	Part Number	Lanyard	Body			Bag	Box
3/4"	W6DC	SS Bead Chain	steel	<b>\$16.07</b>	0.36	10	50
1"	W8DC	SS Bead Chain	steel	<b>17.51</b>	0.37	10	50
1-1/4"	W10DC	SS Bead Chain	steel	<b>27.19</b>	0.62	5	25
1-1/2"	W12DC	SS Bead Chain	steel	<b>47.38</b>	1.03	-	20

Body Size	W-Series Wingstyle Interchange Coupler Repair Kits						
	Part Detail			List Price	Repair Kit Contents (for one coupler)	Package Qty	
	Part Number	Coupler Style	Seal Material			Bag	Box
3/4"	6W-RKIT-V2	all	Nitrile	<b>\$29.52</b>	Bonded Valve, O-Rings, and PTFE Backup	1	25
1"	8W-RKIT-V2	all	Nitrile	<b>33.85</b>	Bonded Valve, O-Rings, and PTFE Backup	1	25
1-1/4"	10W-RKIT-V2	all	Nitrile	<b>35.54</b>	Bonded Valve, O-Rings, and PTFE Backup	1	25
1-1/2"	12W-RKIT-V2	all	Nitrile	<b>37.36</b>	Bonded Valve, O-Rings, and PTFE Backup	1	25

Body Size	W-Series Wingstyle Interchange Nipple Repair Kits						
	Part Detail			List Price	Repair Kit Contents (for one coupler)	Package Qty	
	Part Number	Coupler Style	Seal Material			Bag	Box
3/4"	W6-RKIT-V2	all	Nitrile	<b>\$9.92</b>	Valve Assembly and O-Ring	1	25
1"	W8-RKIT-V2	all	Nitrile	<b>10.42</b>	Valve Assembly and O-Ring	1	25
1-1/4"	W10-RKIT-V2	all	Nitrile	<b>18.06</b>	Valve Assembly and O-Ring	1	25
1-1/2"	W12-RKIT-V2	all	Nitrile	<b>36.36</b>	Valve Assembly and O-Ring	1	25

# WS-Series Hydraulic Couplings

## Interchange Data:

- Snap-Tite 75-Series, Hydraulics Inc. Series-5TV, DNP VFF-HD, Stucchi VOF, Faster OGV, Eaton FD85, Holmby LC

## Materials:

- Machined components are manufactured using solid steel or 316 stainless steel bar stock.
- Stainless steel retaining rings, and springs maximize corrosion resistance and extend service life.
- Steel componentry is plated using ROHS Compliant Zinc Nickel for superior corrosion resistance.
- Rugged high-strength steel sand-cast wing nut for threaded connect and disconnect operation.
- 316 stainless steel nipple connection-threads are coated to prevent galling during connection/disconnection.

## Seal Components:

- Nitrile (Buna-N) seals are standard, providing a temperature range of -40°F to +250°F (-40°C to +121°C).
- PTFE anti-extrusion ring protects main coupling O-Ring from dynamic impulse pressure damage.
- Main valve seal is 'housed' to improve seal integrity during pressurized connection/disconnection.

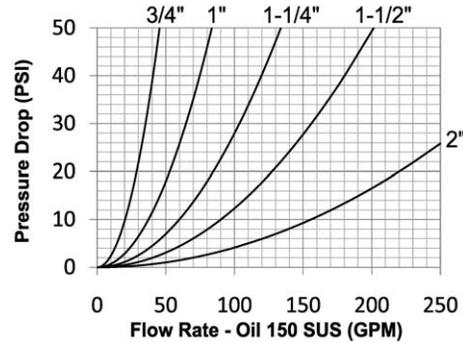

## Rated Pressure Chart:

Body Size	WS-Series High Pressure Wingstyle Interchange (Connected)							
	Steel Coupler/Plug				316 SS Coupler/Plug			
	Maximum Working		Burst		Maximum Working		Burst	
	PSI	Bar	PSI	Bar	PSI	Bar	PSI	Bar
3/4"	5,000	345	32,800	2,200	3,000	200	20,000	1,400
1"	5,000	345	25,100	1,700	3,000	200	20,000	1,400
1-1/4"	5,000	345	25,100	1,700	3,000	200	15,000	1,000
1-1/2"	5,000	345	20,000	1,400	3,000	200	15,000	1,000
2"	5,000	345	15,000	1,000	3,000	200	15,000	1,000

## Technical Specifications:

Body Size	Interchange Standards				Functional Parameters				
	U.S. Military	U.S. Government	International Standards	ANSI/NFPA Standards	Locking Mechanism	Air Inclusion	Fluid Loss	Vacuum Inch HG	Flow ΔP = 30 PSI
3/4"	-	-	-	-	Threaded	10cc	10cc	27.4	35 GPM
1"	-	-	-	-	Threaded	23cc	15cc	27.4	65 GPM
1-1/4"	-	-	-	-	Threaded	50cc	30cc	27.4	105 GPM
1-1/2"	-	-	-	-	Threaded	100cc	60cc	27.4	160 GPM
2"	-	-	-	-	Threaded	200cc	135cc	27.4	270 GPM

## List Price Seal Option Adders:

Body Size	Standard Seal Options										Standard Coupling Options					
	FKM		EPDM		Mil-Nitrile		Fuel Nitrile		Silicone		Wrench Flats		View Port		Oxy-Clean	
	Pre	Add \$	Pre	Add \$	Pre	Add \$	Pre	Add \$	Pre	Add \$	Suf	Add \$	Suf	Add \$	Suf	Add \$
3/4"	F-	\$6.16	P-	\$6.16	M-	\$6.16	JF-	\$6.16	S-	\$6.16	-WF	\$34.00	-VP	\$20.00	-C1	\$20.00
1"	F-	7.70	P-	7.70	M-	7.70	JF-	7.70	S-	7.70	-WF	34.00	-VP	20.00	-C1	20.00
1-1/4"	F-	12.32	P-	12.32	M-	12.32	JF-	12.32	S-	12.32	-WF	34.00	-VP	20.00	-C1	22.00
1-1/2"	F-	15.40	P-	15.40	M-	15.40	JF-	15.40	S-	15.40	-WF	38.00	-VP	24.00	-C1	22.00
2"	F-	21.56	P-	21.56	M-	21.56	JF-	21.56	S-	21.56	-WF	38.00	-VP	28.00	-C1	26.00

- Wrench Flat option not available on 3/4" ORB configuration

## WS-Series Hydraulic Couplings

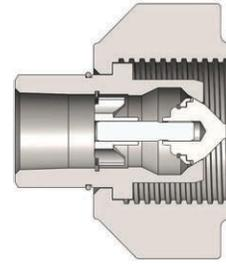

Body Size	WS-Series High Pressure Wingstyle Interchange Coupler (Female Threads)											
	Part Detail			List Price	Length		Maximum OD		Hex Inch	Weight Lb	Package Qty	
	Part Number	Threads	Material		Inch	mm	Inch	mm			Bag	Box
3/4"	6WSF4	1/2" - 14 NPTF	steel	\$168.43	2.76	70.1	3.23	82.0	-	1.86	-	5
3/4"	6WSF6	3/4" - 14 NPTF	steel	163.62	2.76	70.1	3.23	82.0	-	1.80	-	5
3/4"	6WSF6-SS	3/4" - 14 NPTF	316 stainless	2391.52	2.76	70.1	3.23	82.0	-	1.80	-	5
3/4"	6WSBF6	3/4" - 14 BSPP	steel	163.62	2.76	70.1	3.23	82.0	-	1.80	-	5
3/4"	6WSBF6-SS	3/4" - 14 BSPP	316 stainless	2391.52	2.76	70.1	3.23	82.0	-	1.80	-	5
3/4"	6WSOF6	1-1/16" - 12 ORB	steel	180.46	2.76	70.1	3.23	82.0	-	1.78	-	5
1"	8WSF8	1" - 11 1/2 NPTF	steel	245.43	3.45	87.6	4.00	101.6	-	3.30	-	5
1"	8WSF8-SS	1" - 11 1/2 NPTF	316 stainless	2698.12	3.45	87.6	4.00	101.6	-	3.30	-	5
1"	8WSBF8	1" - 11 BSPP	steel	245.43	3.45	87.6	4.00	101.6	-	3.30	-	5
1"	8WSBF8-SS	1" - 11 BSPP	316 stainless	2698.12	3.45	87.6	4.00	101.6	-	3.30	-	5
1"	8WSOF8	1-5/16" - 12 ORB	steel	276.70	3.45	87.6	4.00	101.6	-	3.26	-	5
1-1/4"	10WSF10	1-1/4" - 11 1/2 NPTF	steel	415.06	4.40	111.8	4.65	118.1	-	5.70	-	1
1-1/4"	10WSF10-SS	1-1/4" - 11 1/2 NPTF	316 stainless	4415.11	4.40	111.8	4.65	118.1	-	5.70	-	1
1-1/4"	10WSBF10	1-1/4" - 11 BSPP	steel	415.06	4.40	111.8	4.65	118.1	-	5.70	-	1
1-1/4"	10WSBF10-SS	1-1/4" - 11 BSPP	316 stainless	4415.11	4.40	111.8	4.65	118.1	-	5.70	-	1
1-1/4"	10WSOF10	1-5/8" - 12 ORB	steel	445.14	4.40	111.8	4.65	118.1	-	5.68	-	1
1-1/2"	12WSF12	1-1/2" - 11 1/2 NPTF	steel	613.56	5.13	130.3	5.43	137.9	-	8.90	-	1
1-1/2"	12WSF12-SS	1-1/2" - 11 1/2 NPTF	316 stainless	5396.25	5.13	130.3	5.43	137.9	-	8.90	-	1
1-1/2"	12WSBF12	1-1/2" - 11 BSPP	steel	613.56	5.13	130.3	5.43	137.9	-	8.90	-	1
1-1/2"	12WSBF12-SS	1-1/2" - 11 BSPP	316 stainless	5396.25	5.13	130.3	5.43	137.9	-	8.90	-	1
1-1/2"	12WSOF12	1-7/8" - 12 ORB	steel	661.68	5.13	130.3	5.43	137.9	-	8.87	-	1
2"	16WSF16	2" - 11 1/2 NPTF	steel	878.23	6.09	154.7	6.73	170.9	-	17.10	-	1
2"	16WSF16-SS	2" - 11 1/2 NPTF	316 stainless	6990.60	6.09	154.7	6.73	170.9	-	17.10	-	1
2"	16WSBF16	2" - 11 BSPP	steel	878.23	6.09	154.7	6.73	170.9	-	17.10	-	1
2"	16WSBF16-SS	2" - 11 BSPP	316 stainless	6990.60	6.09	154.7	6.73	170.9	-	17.10	-	1
2"	16WSOF16	2" - 12 ORB	steel	908.32	6.09	154.7	6.73	170.9	-	16.96	-	1



WS coupler with view port example



WS coupler with wrench flats example  
\* Wrench flats may result in reduced pressure performance.

## WS-Series Hydraulic Couplings

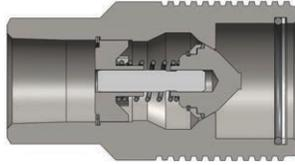

Body Size	WS-Series High Pressure Wingstyle Interchange Nipple (Female Threads)											
	Part Detail			List Price	Length		Maximum OD		Hex Inch	Weight Lb	Package Qty	
	Part Number	Threads	Material		Inch	mm	Inch	mm			Bag	Box
3/4"	WS6F4	1/2" - 14 NPTF	steel	<b>\$155.19</b>	3.27	83.1	1.74	44.2	-	1.23	-	5
3/4"	WS6F6	3/4" - 14 NPTF	steel	<b>150.38</b>	3.27	83.1	1.74	44.2	-	1.20	-	5
3/4"	WS6F6-SS	3/4" - 14 NPTF	316 stainless	<b>1962.27</b>	3.27	83.1	1.74	44.2	-	1.20	-	5
3/4"	WS6BF6	3/4" - 14 BSPP	steel	<b>150.38</b>	3.27	83.1	1.74	44.2	-	1.20	-	5
3/4"	WS6BF6-SS	3/4" - 14 BSPP	316 stainless	<b>1962.27</b>	3.27	83.1	1.74	44.2	-	1.20	-	5
3/4"	WS6OF6	1-1/16" - 12 ORB	steel	<b>174.44</b>	3.27	83.1	1.74	44.2	-	1.17	-	5
1"	WS8F8	1" - 11 1/2 NPTF	steel	<b>180.46</b>	4.18	106.2	2.25	57.2	-	2.50	-	5
1"	WS8F8-SS	1" - 11 1/2 NPTF	316 stainless	<b>2207.56</b>	4.18	106.2	2.25	57.2	-	2.50	-	5
1"	WS8BF8	1" - 11 BSPP	steel	<b>180.46</b>	4.18	106.2	2.25	57.2	-	2.50	-	5
1"	WS8BF8-SS	1" - 11 BSPP	316 stainless	<b>2207.56</b>	4.18	106.2	2.25	57.2	-	2.50	-	5
1"	WS8OF8	1-5/16" - 12 ORB	steel	<b>210.53</b>	4.18	106.2	2.25	57.2	-	2.46	-	5
1-1/4"	WS10F10	1-1/4" - 11 1/2 NPTF	steel	<b>330.85</b>	5.38	136.7	2.63	66.8	-	4.10	-	1
1-1/4"	WS10F10-SS	1-1/4" - 11 1/2 NPTF	316 stainless	<b>2820.77</b>	5.38	136.7	2.63	66.8	-	4.10	-	1
1-1/4"	WS10BF10	1-1/4" - 11 BSPP	steel	<b>330.85</b>	5.38	136.7	2.63	66.8	-	4.10	-	1
1-1/4"	WS10BF10-SS	1-1/4" - 11 BSPP	316 stainless	<b>2820.77</b>	5.38	136.7	2.63	66.8	-	4.10	-	1
1-1/4"	WS10OF10	1-5/8" - 12 ORB	steel	<b>360.92</b>	5.38	136.7	2.63	66.8	-	4.18	-	1
1-1/2"	WS12F12	1-1/2" - 11 1/2 NPTF	steel	<b>517.32</b>	5.98	151.9	3.25	82.6	-	6.90	-	1
1-1/2"	WS12F12-SS	1-1/2" - 11 1/2 NPTF	316 stainless	<b>3433.98</b>	5.98	151.9	3.25	82.6	-	6.90	-	1
1-1/2"	WS12BF12	1-1/2" - 11 BSPP	steel	<b>517.32</b>	5.98	151.9	3.25	82.6	-	6.90	-	1
1-1/2"	WS12BF12-SS	1-1/2" - 11 BSPP	316 stainless	<b>3433.98</b>	5.98	151.9	3.25	82.6	-	6.90	-	1
1-1/2"	WS12OF12	1-7/8" - 12 ORB	steel	<b>541.38</b>	5.98	151.9	3.25	82.6	-	6.86	-	1
2"	WS16F16	2" - 11 1/2 NPTF	steel	<b>842.14</b>	7.05	179.1	4.00	101.6	-	12.50	-	1
2"	WS16F16-SS	2" - 11 1/2 NPTF	316 stainless	<b>4537.75</b>	7.05	179.1	4.00	101.6	-	12.50	-	1
2"	WS16BF16	2" - 11 BSPP	steel	<b>842.14</b>	7.05	179.1	4.00	101.6	-	12.50	-	1
2"	WS16BF16-SS	2" - 11 BSPP	316 stainless	<b>4537.75</b>	7.05	179.1	4.00	101.6	-	12.50	-	1
2"	WS16OF16	2" - 12 ORB	steel	<b>878.23</b>	7.05	179.1	4.00	101.6	-	12.44	-	1

## WS-Series Hydraulic Couplings



Body Size	WS-Series Coupler Rigid Dust Plug						
	Part Detail			List Price	Weight Lb	Package Qty	
	Part Number	Lanyard	Body			Bag	Box
3/4"	6WSDP-A	SS Bead Chain	aluminum	<b>\$41.38</b>	0.31	5	25
1"	8WSDP-A	SS Bead Chain	aluminum	<b>53.05</b>	0.48	-	10
1-1/4"	10WSDP-A	SS Bead Chain	aluminum	<b>74.26</b>	0.61	-	10
1-1/2"	12WSDP-A	SS Bead Chain	aluminum	<b>79.57</b>	0.86	-	5
2"	16WSDP-A	SS Bead Chain	aluminum	<b>132.61</b>	1.05	-	5

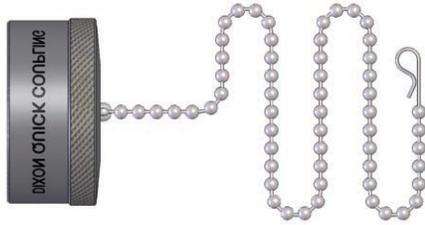

Body Size	WS-Series Nipple Rigid Dust Cap						
	Part Detail			List Price	Weight Lb	Package Qty	
	Part Number	Lanyard	Body			Bag	Box
3/4"	WS6DC-A	SS Bead Chain	aluminum	<b>\$41.38</b>	0.31	5	25
1"	WS8DC-A	SS Bead Chain	aluminum	<b>53.05</b>	0.48	-	10
1-1/4"	WS10DC-A	SS Bead Chain	aluminum	<b>74.26</b>	0.61	-	10
1-1/2"	WS12DC-A	SS Bead Chain	aluminum	<b>79.57</b>	0.86	-	10
2"	WS16DC-A	SS Bead Chain	aluminum	<b>132.61</b>	1.05	-	5

## WS-Series Hydraulic Couplings

Body Size	WS-Series High Pressure Wingstyle Interchange Coupler Seal Kits						
	Part Detail			List Price	Seal Kit Contents	Package Qty	
	Part Number	Coupler Style	Seal Material			Bag	Box
3/4"	6WS-SKIT	all	Nitrile	<b>\$12.50</b>	Body / Valve Seals and Retaining Rings	25	200
1"	8WS-SKIT	all	Nitrile	<b>14.04</b>	Body / Valve Seals and Retaining Rings	25	200
1-1/4"	10WS-SKIT	all	Nitrile	<b>16.85</b>	Body / Valve Seals and Retaining Rings	25	100
1-1/2"	12WS-SKIT	all	Nitrile	<b>20.21</b>	Body / Valve Seals and Retaining Rings	25	100
2"	16WS-SKIT	all	Nitrile	<b>21.33</b>	Body / Valve Seals and Retaining Rings	25	100

Body Size	WS-Series BOP Wingstyle Interchange Coupler Seal Kits						
	Part Detail			List Price	Seal Kit Contents	Package Qty	
	Part Number	Coupler Style	Seal Material			Bag	Box
3/4"	6BOP-SKIT	all	FR FKM	<b>\$19.58</b>	Body / Valve Seals and Retaining Rings	25	200
1"	8BOP-SKIT	all	FR FKM	<b>21.97</b>	Body / Valve Seals and Retaining Rings	25	200
1-1/4"	10BOP-SKIT	all	FR FKM	<b>23.73</b>	Body / Valve Seals and Retaining Rings	25	100
1-1/2"	12BOP-SKIT	all	FR FKM	<b>24.48</b>	Body / Valve Seals and Retaining Rings	25	100
2"	16BOP-SKIT	all	FR FKM	<b>27.23</b>	Body / Valve Seals and Retaining Rings	25	100

Body Size	WS-Series High Pressure Wingstyle Interchange Coupler Repair Kits						
	Part Detail			List Price	Repair Kit Contents (for one coupler or nipple)	Package Qty	
	Part Number	Coupler Style	Seal Material			Bag	Box
3/4"	6WS-RKIT	all	Nitrile	<b>\$50.31</b>	Valve Assembly, O-Ring, and PTFE B.U.	1	25
1"	8WS-RKIT	all	Nitrile	<b>81.09</b>	Valve Assembly, O-Ring, and PTFE B.U.	1	25
1-1/4"	10WS-RKIT	all	Nitrile	<b>87.69</b>	Valve Assembly, O-Ring, and PTFE B.U.	1	25
1-1/2"	12WS-RKIT	all	Nitrile	<b>94.34</b>	Valve Assembly, O-Ring, and PTFE B.U.	1	25
2"	16WS-RKIT	all	Nitrile	<b>158.40</b>	Valve Assembly, O-Ring, and PTFE B.U.	1	25

# T-Series Hydraulic Couplings

### Interchange Data:

- High Pressure Screw-Together Interchange
- Parker/Pioneer 3000-Series, Enerpac C604, Stucchi IVHP
- Hansen WS56000, Snap-Tite 76-Series, DNP PVM

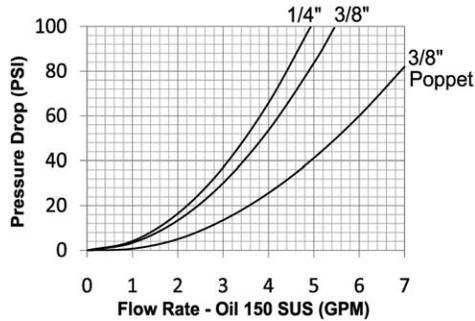

### Seal Components:

- Urethane seal is standard in ball valve couplers and provides resistance to extrusion when subjected to high pressure - temperature range -40°F to +180°F (-40°C to +82°C).
- Nitrile seals are standard in poppet valve couplings, providing a temperature range of -40°F to +250°F (-40°C to +121°C).

### Materials:

- Machined components are manufactured using solid steel or 316 stainless steel bar stock.
- Chrome steel ball valve is mechanically seated to improve low pressure sealing performance.
- Steel nipples are machined from solid high strength steel bar stock.
- Steel componentry is plated using ROHS Compliant Trivalent Chrome.

### Rated Pressure Chart:

Body Size	T-Series High Pressure Enerpac Interchange (Connected)															
	Steel Ball Coupler/Plug				316 SS Ball Coupler/Plug				Steel Poppet Coupler/Plug				316 SS Poppet Coupler/Plug			
	Max. Working		Burst		Max. Working		Burst		Max. Working		Burst		Max. Working		Burst	
	PSI	Bar	PSI	Bar	PSI	Bar	PSI	Bar	PSI	Bar	PSI	Bar	PSI	Bar	PSI	Bar
1/4"	10,000	700	34,300	2,350	-	-	-	-	-	-	-	-	-	-	-	-
3/8"	10,000	700	30,000	2,050	10,000	700	30,900	2,100	10,000	700	36,800	2,500	10,000	700	36,500	2,500

### Technical Specifications:

Body Size	Interchange Standards				Functional Parameters				
	U.S. Military	U.S. Government	International Standards	ANSI/NFPA Standards	Valve Style	Air Inclusion	Fluid Loss	Vacuum Inch HG	Flow ΔP = 60 PSI
1/4"	-	-	ISO14540	-	Ball	0.97	0.56	N/R	3.8 GPM
3/8"	-	-	ISO14540	-	Ball	2.04	0.98	N/R	4.2 GPM
3/8"	-	-	ISO14540	-	Poppet	1.56	0.77	N/R	6 GPM

### List Price Seal Option Adders:

Body Size	Seal Options				Kalrez® Seal Options						Valve Options				Treatments	
	FKM		Mil-Nitrile		4079		6375		7075		Unvalved		316 SS		Oxy-Clean	
	Pre	Add \$	Pre	Add \$	Pre	Add \$	Pre	Add \$	Pre	Add \$	Suf	Add \$	Suf	Add \$	Suf	Add \$
1/4"	F-	\$0.00	M-	\$0.00	K4-	POR	K6-	POR	K7-	POR	-E	-\$3.00	SSV	N/A	-C1	\$12.00
3/8"	F-	0.00	M-	0.00	K4-	POR	K6-	POR	K7-	POR	-E	-4.40	SSV	N/A	-C1	12.00



## T-Series Hydraulic Couplings

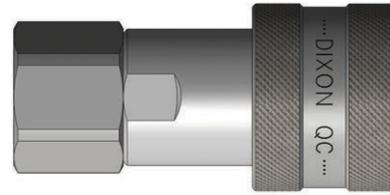
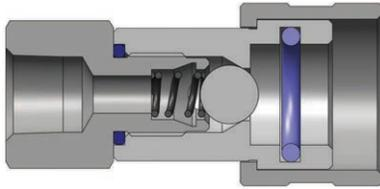

Body Size	T-Series High Pressure Ball Interchange Coupler (Female Threads)											
	Part Detail			List Price	Length		Maximum OD		Hex Inch	Weight Lb	Package Qty	
	Part Number	Threads	Material		Inch	mm	Inch	mm			Bag	Box
3/8"	3TF3	3/8" - 18 NPTF	steel	\$32.21	2.83	71.9	1.39	35.3	1"	0.49	5	25

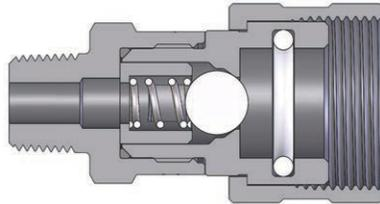

Body Size	T-Series High Pressure Ball Interchange Coupler (Male Threads)											
	Part Detail			List Price	Length		Maximum OD		Hex Inch	Weight Lb	Package Qty	
	Part Number	Threads	Material		Inch	mm	Inch	mm			Bag	Box
1/4"	2TM2	1/4" - 18 NPTF	steel	\$29.19	2.36	59.9	1.14	29.0	13/16"	0.25	5	50
3/8"	3TM3	3/8" - 18 NPTF	steel	32.21	2.58	65.6	1.39	35.3	1"	0.49	5	25
3/8"	3TM3-SS	3/8" - 18 NPT	316 stainless	198.34	2.83	71.9	1.39	35.3	1"	0.49	5	25

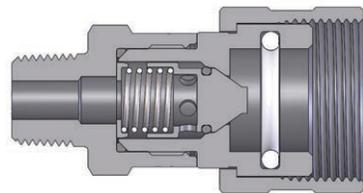

Body Size	T-Series High Pressure Poppet Interchange Coupler (Male Threads)											
	Part Detail			List Price	Length		Maximum OD		Hex Inch	Weight Lb	Package Qty	
	Part Number	Threads	Material		Inch	mm	Inch	mm			Bag	Box
3/8"	3TM3-PV	3/8" - 18 NPT	steel	\$49.16	2.78	70.7	1.36	34.5	1"	0.49	5	25
3/8"	3TM3-SS-PV	3/8" - 18 NPT	316 stainless	228.69	2.78	70.7	1.36	34.5	1"	0.49	5	25

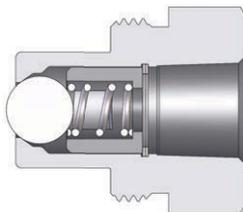

Body Size	T-Series High Pressure Ball Interchange Nipple (Female Threads)											
	Part Detail			List Price	Length		Maximum OD		Hex Inch	Weight Lb	Package Qty	
	Part Number	Threads	Material		Inch	mm	Inch	mm			Bag	Box
1/4"	T2F2	1/4" - 18 NPTF	steel	\$17.52	1.30	33.0	1.12	28.5	3/4"	0.14	5	50
3/8"	T3F3	3/8" - 18 NPTF	steel	18.45	1.56	39.6	1.24	31.5	15/16"	0.23	5	25
3/8"	T3F3-SS	3/8" - 18 NPT	316 stainless	109.66	1.56	39.6	1.24	31.5	15/16"	0.23	5	25

## T-Series Hydraulic Couplings

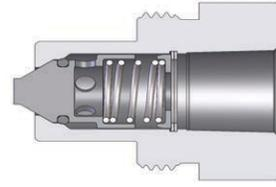
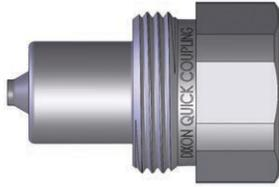

Body Size	T-Series High Pressure Poppet Interchange Nipple (Female Threads)											
	Part Detail			List Price	Length		Maximum OD		Hex Inch	Weight Lb	Package Qty	
	Part Number	Threads	Material		Inch	mm	Inch	mm			Bag	Box
3/8"	T3F3-PV	3/8" - 18 NPT	steel	<b>\$27.68</b>	1.53	38.9	1.19	30.226	15/16"	0.23	5	25
3/8"	T3F3-SS-PV	3/8" - 18 NPT	316 stainless	<b>126.57</b>	1.53	38.9	1.19	30.226	15/16"	0.23	5	25



Body Size	T-Series Coupler Rigid Dust Plug						
	Part Detail			List Price	Weight Lb	Package Qty	
	Part Number	Lanyard	Body			Bag	Box
1/4"	2TDP	rubber	steel	<b>\$6.82</b>	0.10	5	50
3/8"	3TDP	rubber	steel	<b>6.82</b>	0.16	5	25

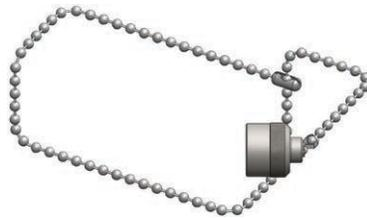

Body Size	T-Series Nipple Rigid Dust Cap						
	Part Detail			List Price	Weight Lb	Package Qty	
	Part Number	Lanyard	Body			Bag	Box
1/4"	T2DC	SS bead chain	steel	<b>\$10.59</b>	0.12	5	50
3/8"	T3DC	SS bead chain	steel	<b>10.59</b>	0.19	5	25

Body Size	T-Series High Pressure Enerpac Interchange Coupler Seal Kits						
	Part Detail			List Price	Seal Kit Contents	Package Qty	
	Part Number	Coupler Style	Seal Material			Bag	Box
1/4"	2T-SKIT	ball valve	Urethane	<b>\$3.86</b>	Body Seal	25	200
3/8"	3T-SKIT	ball valve	Urethane	<b>4.23</b>	Body Seal	25	200

# CVV-Series Hydraulic Couplings

## Interchange Data:

- European Screw-Together Interchange
- Inteva STG-Series, Faster CVV-Series, DNP PVV3, Voswinkel Type-HS

## Materials:

- Machined components are manufactured using solid steel bar stock.
- Steel retaining rings, and springs maximize service life in rugged environments.
- Steel componentry is plated using ROHS Compliant Trivalent Chrome.

## Seal Components:

- Nitrile (Buna-N) seals are standard, providing a temperature range of -13°F to +257°F (-25°C to +125°C).
- Nipples have a PTFE Anti-Extrusion ring to prevent O-Ring damage during dynamic impulse service.

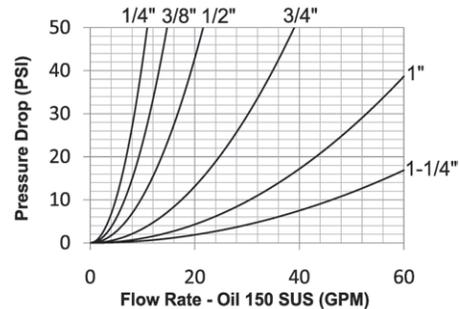

## Rated Pressure Chart:

Body Size	CVV-Series European Screw-Together Interchange			
	Coupler/Plug Coupled			
	Maximum Working		Burst	
	PSI	Bar	PSI	Bar
1/4"	6,500	450	26,000	1,800
3/8"	6,500	450	26,000	1,800
1/2"	5,800	400	23,200	1,600
3/4"	5,800	400	23,200	1,600
1"	4,400	300	17,600	1,200
1-1/4"	4,400	300	17,600	1,200

## Technical Specifications:

Body Size	Interchange Standards				Functional Parameters				
	U.S. Military	U.S. Government	International Standards	ANSI/NFPA Standards	Locking Mechanism	Air Inclusion	Fluid Loss	Vacuum Inch HG	Flow $\Delta P = 22$ PSI
1/4"	-	-	-	-	Threaded	N/A	N/A	27.4	7 GPM
3/8"	-	-	-	-	Threaded	N/A	N/A	27.4	10 GPM
1/2"	-	-	-	-	Threaded	N/A	N/A	27.4	15 GPM
3/4"	-	-	-	-	Threaded	N/A	N/A	27.4	26 GPM
1"	-	-	-	-	Threaded	N/A	N/A	27.4	45 GPM
1-1/4"	-	-	-	-	Threaded	N/A	N/A	27.4	70 GPM

Note: Threaded sleeves enable easy connection and disconnection while system is under residual pressure only.

## CVV-Series Hydraulic Couplings

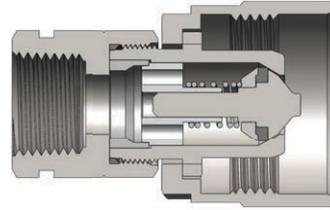
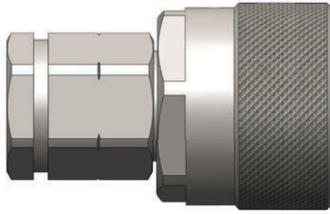

Body Size	CVV-Series European Interchange Coupler (Female Threads)											
	Part Detail			List Price	Length		Maximum OD		Hex mm	Weight Lb	Package Qty	
	Part Number	Threads	Material		Inch	mm	Inch	mm			Bag	Box
1/4"	2CVVF2	1/4" - 18 NPTF	steel	<b>\$57.76</b>	2.33	59.3	1.34	34.0	19	0.26	10	50
1/4"	2CVVBF2	1/4" - 19 BSPP	steel	<b>57.76</b>	2.33	59.3	1.34	34.0	19	0.26	10	50
1/4"	2CVVFM1415	M14X1.5	steel	<b>57.76</b>	2.33	59.3	1.34	34.0	19	0.29	10	50
3/8"	3CVVF3	3/8" - 18 NPTF	steel	<b>57.76</b>	2.41	61.2	1.34	34.0	22	0.50	10	30
3/8"	3CVVBF3	3/8" - 19 BSPP	steel	<b>57.76</b>	2.41	61.2	1.34	34.0	22	0.50	10	30
3/8"	3CVVFM1615	M16X1.5	steel	<b>57.76</b>	2.41	61.2	1.34	34.0	22	0.48	10	30
1/2"	4CVVF4	1/2" - 14 NPTF	steel	<b>65.83</b>	2.66	67.5	1.65	41.8	27	0.75	5	25
1/2"	4CVVOF4	3/4" - 16 ORB	steel	<b>65.83</b>	2.66	67.5	1.65	41.8	27	0.75	5	25
1/2"	4CVVBF4	1/2" - 14 BSPP	steel	<b>65.83</b>	2.66	67.5	1.65	41.8	27	0.76	5	25
1/2"	4CVVFM1815	M18X1.5	steel	<b>65.83</b>	2.66	67.5	1.65	41.8	27	0.78	5	25
1/2"	4CVVOF5	7/8" - 14ORB	steel	<b>65.83</b>	2.66	67.5	1.65	41.8	27	0.78	5	25
1/2"	4CVVFM2215	M22X1.5	steel	<b>65.83</b>	2.66	67.5	1.65	41.8	27	0.75	5	25
3/4"	6CVVF6	3/4" - 14 NPTF	steel	<b>101.37</b>	3.15	80.0	1.89	48.0	36	1.28	-	10
3/4"	6CVVBF6	3/4" - 14 BSPP	steel	<b>101.37</b>	3.15	80.0	1.89	48.0	36	1.28	-	10
3/4"	6CVVFM2215	M22X1.5	steel	<b>101.37</b>	3.15	80.0	1.89	48.0	36	1.28	-	10
1"	8CVVF8	1" - 11 1/2 NPTF	steel	<b>140.35</b>	3.30	83.9	2.35	59.8	41	1.78	-	10
1"	8CVVBF8	1" - 11 BSPP	steel	<b>140.35</b>	3.30	83.9	2.35	59.8	41	1.78	-	10
1-1/4"	10CVVF10	1-1/4" - 11 1/2 NPTF	steel	<b>431.22</b>	5.59	142.0	3.14	79.8	50	2.64	-	10
1-1/4"	10CVVBF10	1-1/4" - 11 BSPP	steel	<b>431.22</b>	5.59	142.0	3.14	79.8	50	2.64	-	10

## CVV-Series Hydraulic Couplings

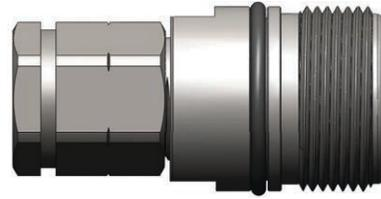
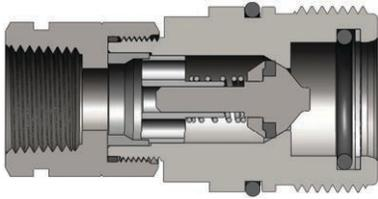

Body Size	CVV-Series European Interchange Nipple (Female Threads)											
	Part Detail			List Price	Length		Maximum OD		Hex mm	Weight Lb	Package Qty	
	Part Number	Threads	Material		Inch	mm	Inch	mm			Bag	Box
1/4"	CVV2F2	1/4" - 18 NPTF	steel	<b>\$40.39</b>	2.36	60.0	0.94	24.0	19	0.25	10	50
1/4"	CVV2BF2	1/4" - 19 BSPP	steel	<b>40.39</b>	2.36	60.0	0.94	24.0	19	0.25	10	50
1/4"	CVV2FM1415	M14X1.5	steel	<b>40.39</b>	2.36	60.0	0.94	24.0	19	0.23	10	50
3/8"	CVV3F3	3/8" - 18 NPTF	steel	<b>40.39</b>	2.52	64.0	1.10	28.0	22	0.49	10	30
3/8"	CVV3BF3	3/8" - 19 BSPP	steel	<b>40.39</b>	2.52	64.0	1.10	28.0	22	0.49	10	30
3/8"	CVV3FM1615	M16X1.5	steel	<b>40.39</b>	2.52	64.0	1.10	28.0	22	0.46	10	30
1/2"	CVV4F4	1/2" - 14 NPTF	steel	<b>52.61</b>	2.76	70.0	1.42	36.0	27	0.75	5	25
1/2"	CVV4OF4	3/4" - 16 ORB	steel	<b>52.61</b>	2.76	70.0	1.42	36.0	27	0.75	5	25
1/2"	CVV4BF4	1/2" - 14 BSPP	steel	<b>52.61</b>	2.76	70.0	1.42	36.0	27	0.76	5	25
1/2"	CVV4FM1815	M18X1.5	steel	<b>52.61</b>	2.76	70.0	1.42	36.0	27	0.78	5	25
1/2"	CVV4OF5	7/8" - 14ORB	steel	<b>52.61</b>	2.76	70.0	1.42	36.0	27	0.78	5	25
1/2"	CVV4FM2215	M22X1.5	steel	<b>52.61</b>	2.76	70.0	1.42	36.0	27	0.75	5	25
3/4"	CVV6F6	3/4" - 14 NPTF	steel	<b>88.37</b>	3.39	86.0	1.65	42.0	36	1.28	-	10
3/4"	CVV6BF6	3/4" - 14 BSPP	steel	<b>88.37</b>	3.39	86.0	1.65	42.0	36	1.28	-	10
3/4"	CVV6FM2215	M22X1.5	steel	<b>88.37</b>	3.39	86.0	1.65	42.0	36	1.28	-	10
1"	CVV8F8	1" - 11 1/2 NPTF	steel	<b>127.36</b>	3.94	100.0	1.89	48.0	41	1.78	-	10
1"	CVV8BF8	1" - 11 BSPP	steel	<b>127.36</b>	3.94	100.0	1.89	48.0	41	1.78	-	10
1-1/4"	CVV10F10	1-1/4" - 11 1/2 NPTF	steel	<b>316.45</b>	5.91	150.0	2.76	70.0	50	2.64	-	10
1-1/4"	CVV10BF10	1-1/4" - 11 BSPP	steel	<b>316.45</b>	5.91	150.0	2.76	70.0	50	2.64	-	10

## CVV-Series Hydraulic Couplings



Body Size	CVV-Series European Interchange Dust Plug						
	Part Detail			List Price	Weight Lb	Package Qty	
	Part Number	Lanyard	Body			Bag	Box
1/4"	2CVVDP	plastic	plastic	<b>\$16.63</b>	0.02	5	25
3/8"	3CVVDP	plastic	plastic	<b>6.76</b>	0.03	5	25
1/2"	4CVVDP	plastic	plastic	<b>7.80</b>	0.06	5	25
3/4"	6CVVDP	plastic	plastic	<b>8.08</b>	0.07	5	25
1"	8CVVDP	plastic	plastic	<b>8.15</b>	0.08	5	25
1-1/4"	10CVVDP	plastic	plastic	<b>15.42</b>	0.11	-	10



Body Size	CVV-Series European Interchange Dust Cap						
	Part Detail			List Price	Weight Lb	Package Qty	
	Part Number	Lanyard	Body			Bag	Box
1/4"	CVV2DC	plastic	plastic	<b>\$16.63</b>	0.02	5	25
3/8"	CVV3DC	plastic	plastic	<b>5.63</b>	0.03	5	25
1/2"	CVV4DC	plastic	plastic	<b>6.06</b>	0.04	5	25
3/4"	CVV6DC	plastic	plastic	<b>6.80</b>	0.08	5	25
1"	CVV8DC	plastic	plastic	<b>6.93</b>	0.10	5	25
1-1/4"	CVV10DC	plastic	plastic	<b>10.66</b>	0.15	-	10

## Dixon Blowout Prevention Couplings

### Application:

- designed specifically for blow-out prevention systems on drilling rigs

### Product Offering:

- VEP-BOP Series:
  - thread to connect flush face interchange
  - ¾" to 1½" in steel
- H-BOP Series:
  - ISO-B interchange
  - ½" to 1" in steel and 316 stainless
- WS-BOP Series:
  - same reliable Wing coupling you know, new red components
  - ¾" to 2" in steel and 316 stainless

### Features:

- fire tested and Lloyd's certified to 700°C (1300°F) in accordance with API 16D, certificate available upon request
- certified at a test pressure of 5,000 PSI
- red powder coated components and external seals provide easy BOP approved identification
- critical seals are FKM

2014  
**NEW**



# VEP-BOP Series Hydraulic Couplings

**NEW** 2014

## Interchange Data:

- Stucchi VEP/VEP-HD Series, DNP FSI-BOP Series

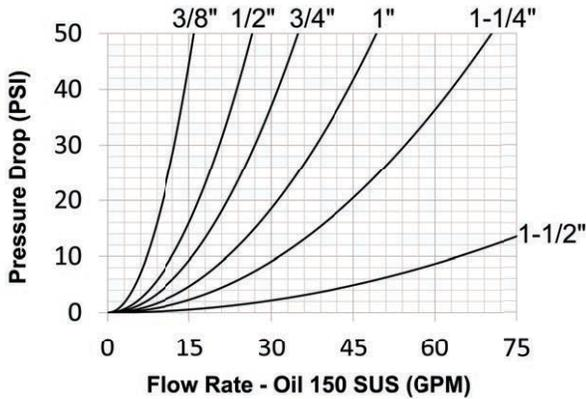

## Seal Components:

- Blow-out Prevention (BOP) coupling critical seals are severe service FKM
- PTFE Anti-Extrusion ring protects main coupling valve seal from dynamic impulse pressure damage

## Materials:

- Machined components are manufactured using solid steel bar stock
- Stainless steel retaining rings and springs maximize corrosion resistance and extend service life
- Steel components are plated using ROHS Compliant Zinc Nickel
- Red powder coated components and external O-rings for easy BOP service identification

- BOP couplings have been fire tested and Lloyd's certified to 700°C (1300°F) in accordance with API 16D. Certificate available upon request.
- Use VEP dust caps and dust plugs found on page 123.

Lloyd's Test Pressure	
Body Size	PSI
3/8"	5,000
1/2"	5,000
3/4"	5,000
1"	5,000
1-1/4"	5,000
1-1/2"	5,000

## Rated Pressure Chart:

VEP-BOP Series Interchange																
Body Size	Pressure Rating				Burst Pressure						Max. Pressure Connect		Max. Pressure Disconnect		Rated Flow $\Delta P=21.75\text{psi}$	
	ISO Working		Max. Impulse		Connected		Coupler		Plug		psi	MPa	psi	MPa	GPM	L/min
	psi	MPa	psi	MPa	psi	MPa	psi	MPa	psi	MPa						
3/8"	5,500	38	8,000	55	22,000	152	18,000	124	20,000	138	4,500	31	4,500	31	10.5	40
1/2"	5,500	38	8,000	55	22,000	152	18,000	124	20,000	138	4,500	31	4,500	31	17.5	66
3/4"	5,500	38	8,000	55	22,000	152	18,000	124	20,000	138	4,500	31	4,500	31	22.7	85
1"	5,500	38	7,500	52	22,000	152	14,500	100	20,000	138	3,625	25	3,625	25	32.5	123
1-1/4"	5,000	35	7,000	48	20,000	138	14,500	100	16,000	110	3,625	25	3,625	25	46.4	174
1-1/2"	5,000	31	5,800	40	18,000	124	12,000	83	14,500	100	3,000	21	3,000	21	95.0	360

- Contact factory for availability of other end configurations



## VEP-BOP Series Hydraulic Couplings

**NEW** 2014

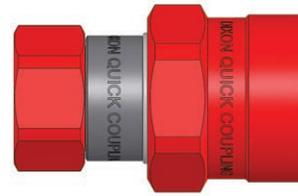
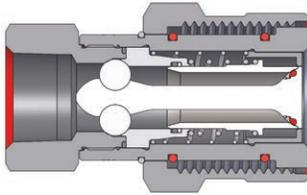

Body Size	VEP-BOP Series Blowout Prevention Safety Coupler (Female Threads)											
	Part Detail			List Price	Length		Maximum OD		Hex mm	Weight Lb	Package Qty	
	Part Number	Threads	Material		Inch	mm	Inch	mm			Bag	Box
3/8"	3VEP3-BOP	3/8" - 18 NPTF	steel	\$140.07	2.55	64.8	1.62	41.1	25	0.63	-	20
1/2"	4VEPF4-BOP	1/2" - 14 NPTF	steel	182.33	3.08	78.2	1.98	50.3	30	1.36	-	15
3/4"	6VEPF6-BOP	3/4" - 14 NPTF	steel	237.10	3.37	85.6	2.19	55.6	38	1.70	-	1
1"	8VEPF8-BOP	1" - 11 1/2 NPTF	steel	300.46	3.89	98.8	2.46	62.5	44	2.44	-	1
1-1/4"	10VEPF10-BOP	1-1/4" - 11 1/2 NPTF	steel	347.42	4.40	111.8	2.70	68.6	55	3.76	-	1
1-1/2"	12VEPF12-BOP	1-1/2" - 11 1/2 NPTF	steel	996.38	5.28	134.1	3.74	95.0	63	9.09	-	1

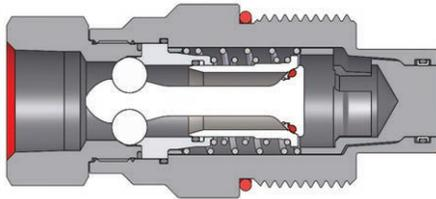

Body Size	VEP-BOP Series Blowout Prevention Safety Nipple (Female Threads)											
	Part Detail			List Price	Length		Maximum OD		Hex mm	Weight Lb	Package Qty	
	Part Number	Threads	Material		Inch	mm	Inch	mm			Bag	Box
3/8"	VEP3F3-BOP	3/8" - 18 NPTF	steel	\$158.87	3.28	83.3	1.48	37.6	25	0.76	-	20
1/2"	VEP4F4-BOP	1/2" - 14 NPTF	steel	182.33	3.87	98.3	1.86	47.2	30	1.30	-	10
3/4"	VEP6F6-BOP	3/4" - 14 NPTF	steel	213.62	4.12	104.6	1.98	50.3	38	1.84	-	1
1"	VEP8F8-BOP	1" - 11 1/2 NPTF	steel	246.49	4.95	125.7	2.20	55.9	44	2.65	-	1
1-1/4"	VEP10F10-BOP	1-1/4" - 11 1/2 NPTF	steel	347.42	5.43	137.9	2.73	69.3	55	3.18	-	1
1-1/2"	VEP12F12-BOP	1-1/2" - 11 1/2 NPTF	steel	952.37	6.63	164.4	3.74	95.0	63	9.02	-	1

## WS-BOP Series Hydraulic Couplings

**NEW** 2014

### Interchange Data:

- Snap-Tite 75-Series, DNP VFF-HD BOP Series

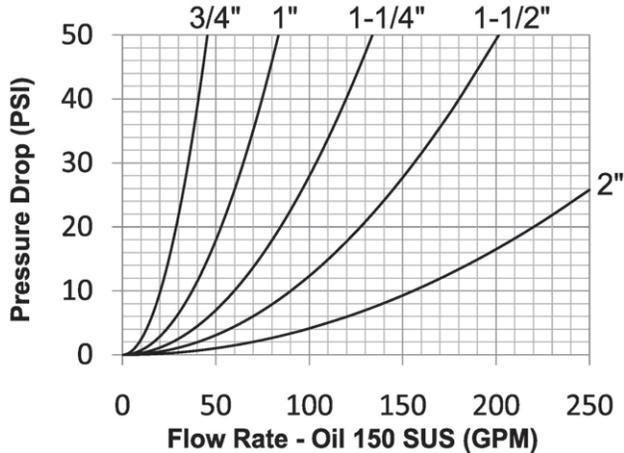

### Seal Components:

- Blow-out Prevention (BOP) couplings contain severe service FKM seals
- PTFE Anti-Extrusion ring protects main coupling valve seal from dynamic impulse pressure damage
- Main valve seal is "housed" to improve seal integrity during pressurized connection/disconnection

### Materials:

- Machined components are manufactured using solid steel or 316 stainless steel bar stock.
- Stainless steel retaining rings, and springs maximize corrosion resistance and extend service life.
- Steel componentry is plated using ROHS Compliant Zinc Nickel.
- Rugged high-strength steel wing nut for threaded connect and disconnect operation.
- 316 stainless steel nipple connection-threads are coated to prevent galling during connection/disconnection.
- Red powder coated coupler wing-nut and external nipple O-ring for easy BOP service identification.

- BOP couplings have been fire tested and Lloyd's certified to 700°C (1300°F) in accordance with API 16D. Certificate available upon request.
- Use WS dust caps and dust plugs found on page 132.

### Rated Pressure Chart:

WS-BOP Series High Pressure Wingstyle Interchange (Connected)								
Body Size	Steel Coupler/Plug				316 SS Coupler/Plug			
	Maximum Working		Burst		Maximum Working		Burst	
	PSI	Bar	PSI	Bar	PSI	Bar	PSI	Bar
3/4"	5,000	345	32,800	2,200	5,000	345	20,000	1,400
1"	5,000	345	25,100	1,700	5,000	345	20,000	1,400
1-1/4"	5,000	345	25,100	1,700	5,000	345	15,000	1,000
1-1/2"	5,000	345	20,000	1,400	5,000	345	15,000	1,000
2"	5,000	345	15,000	1,000	5,000	345	15,000	1,000

### Technical Specifications:

Body Size	Functional Parameters					Lloyd's Test Pressure
	Locking Mechanism	Air Inclusion	Fluid Loss	Vacuum Inch HG	Flow $\Delta P = 30$ PSI	PSI
3/4"	Threaded	10cc	10cc	27.4	35 GPM	5,000
1"	Threaded	23cc	15cc	27.4	65 GPM	5,000
1-1/4"	Threaded	50cc	30cc	27.4	105 GPM	5,000
1-1/2"	Threaded	100cc	60cc	27.4	160 GPM	5,000
2"	Threaded	200cc	135cc	27.4	270 GPM	5,000

## WS-BOP Series Hydraulic Couplings

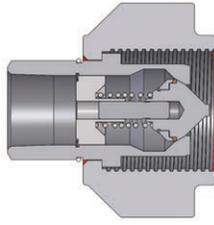

Body Size	WS-BOP Series Blowout Prevention Safety Coupler (Female Threads)											
	Part Detail			List Price	Length		Maximum OD		Hex Inch	Weight Lb	Package Qty	
	Part Number	Threads	Material		Inch	mm	Inch	mm			Bag	Box
3/4"	6WSF4-BOP	1/2" - 14 NPTF	steel	<b>\$252.64</b>	2.76	70.1	3.23	82.0	-	1.86	-	5
3/4"	6WSF6-BOP	3/4" - 14 NPTF	steel	<b>240.61</b>	2.76	70.1	3.23	82.0	-	1.80	-	5
3/4"	6WSF6-SS-BOP	3/4" - 14 NPTF	316 stainless	<b>2820.77</b>	2.76	70.1	3.23	82.0	-	1.80	-	5
1"	8WSF8-BOP	1" - 11 1/2 NPTF	steel	<b>336.86</b>	3.45	87.6	4.00	101.6	-	3.30	-	5
1"	8WSF8-SS-BOP	1" - 11 1/2 NPTF	316 stainless	<b>2943.41</b>	3.45	87.6	4.00	101.6	-	3.30	-	5
1-1/4"	10WSF10-BOP	1-1/4" - 11 1/2 NPTF	steel	<b>541.38</b>	4.40	111.8	4.65	118.1	-	5.70	-	1
1-1/4"	10WSF10-SS-BOP	1-1/4" - 11 1/2 NPTF	316 stainless	<b>5077.38</b>	4.40	111.8	4.65	118.1	-	5.70	-	1
1-1/2"	12WSF12-BOP	1-1/2" - 11 1/2 NPTF	steel	<b>769.96</b>	5.13	130.3	5.43	137.9	-	8.90	-	1
1-1/2"	12WSF12-SS-BOP	1-1/2" - 11 1/2 NPTF	316 stainless	<b>6205.69</b>	5.13	130.3	5.43	137.9	-	8.90	-	1
2"	16WSF16-BOP	2" - 11 1/2 NPTF	steel	<b>1082.76</b>	6.09	154.7	6.73	170.9	-	17.10	-	1
2"	16WSF16-SS-BOP	2" - 11 1/2 NPTF	316 stainless	<b>8008.64</b>	6.09	154.7	6.73	170.9	-	17.10	-	1

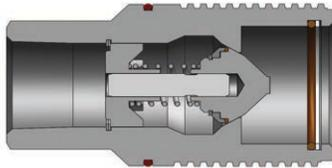

Body Size	WS-BOP Series Blowout Prevention Safety Nipple (Female Threads)											
	Part Detail			List Price	Length		Maximum OD		Hex Inch	Weight Lb	Package Qty	
	Part Number	Threads	Material		Inch	mm	Inch	mm			Bag	Box
3/4"	WS6F4-BOP	1/2" - 14 NPTF	steel	<b>\$192.49</b>	3.27	83.1	1.74	44.2	-	1.23	-	5
3/4"	WS6F6-BOP	3/4" - 14 NPTF	steel	<b>186.47</b>	3.27	83.1	1.74	44.2	-	1.20	-	5
3/4"	WS6F6-SS-BOP	3/4" - 14 NPTF	316 stainless	<b>2330.20</b>	3.27	83.1	1.74	44.2	-	1.20	-	5
1"	WS8F8-BOP	1" - 11 1/2 NPTF	steel	<b>198.50</b>	4.18	106.2	2.25	57.2	-	2.50	-	5
1"	WS8F8-SS-BOP	1" - 11 1/2 NPTF	316 stainless	<b>2698.12</b>	4.18	106.2	2.25	57.2	-	2.50	-	5
1-1/4"	WS10F10-BOP	1-1/4" - 11 1/2 NPTF	steel	<b>397.01</b>	5.38	136.7	2.63	66.8	-	4.10	-	1
1-1/4"	WS10F10-SS-BOP	1-1/4" - 11 1/2 NPTF	316 stainless	<b>3231.56</b>	5.38	136.7	2.63	66.8	-	4.10	-	1
1-1/2"	WS12F12-BOP	1-1/2" - 11 1/2 NPTF	steel	<b>601.53</b>	5.98	151.9	3.25	82.6	-	6.90	-	1
1-1/2"	WS12F12-SS-BOP	1-1/2" - 11 1/2 NPTF	316 stainless	<b>3949.07</b>	5.98	151.9	3.25	82.6	-	6.90	-	1
2"	WS16F16-BOP	2" - 11 1/2 NPTF	steel	<b>1010.57</b>	7.05	179.1	4.00	101.6	-	12.50	-	1
2"	WS16F16-SS-BOP	2" - 11 1/2 NPTF	316 stainless	<b>5198.59</b>	7.05	179.1	4.00	101.6	-	12.50	-	1

# H-BOP Series Hydraulic Couplings

2014  
**NEW**

### Interchange Data:

- Eaton/Hansen HKFR-Series, DNP HNV-BOP Series
- Interchangeable to ISO7241 Series B

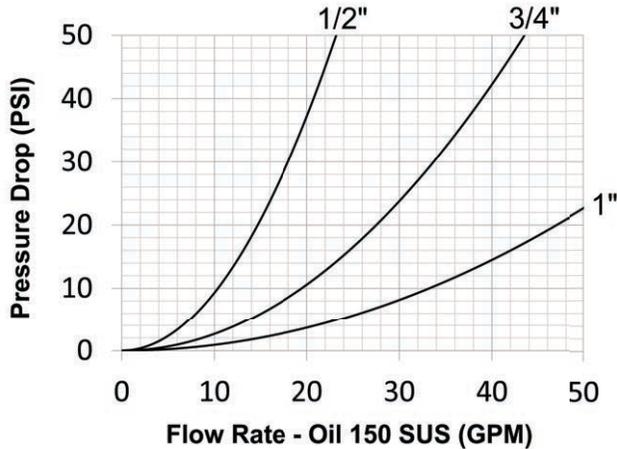

### Seal Components:

- Blow-out Prevention (BOP) couplings contain severe service FKM seals
- PTFE Anti-Extrusion ring protects main coupling body seal from dynamic impulse pressure damage
- Coupler has redundant O-ring sealing system
- Valve seals are crimped in place to maintain integrity during excessive flow conditions and pressurized connection

### Materials:

- Machined components are manufactured using solid steel or 316 stainless steel bar stock.
- Stainless steel balls, retaining rings, and springs maximize corrosion resistance and extend service life.
- Steel componentry is plated using ROHS Compliant Trivalent Chrome.
- Steel coupler sleeves are hardened to resist deformation and maximize service life.
- Steel nipples are hardened to provide heavy duty performance and resist brinelling.
- Red powder coated coupler sleeve and nipple hex for easy BOP service identification
- Locking sleeve is standard

- BOP couplings have been fire tested and Lloyd's certified to 700°C (1300°F) in accordance with API 16D. Certificate available upon request.
- Use H-Series dust caps and dust plugs found on pages 67 and 68.

### Rated Pressure Chart:

Body Size	H-BOP-Series Blowout Prevention Safety Interchange									
	Steel Coupler/Plug				316 SS Coupler/Plug				Lloyd's Test Pressure	Flow $\Delta P = 22$ PSI
	Maximum Working		Burst		Maximum Working		Burst			
	PSI	Bar	PSI	Bar	PSI	Bar	PSI	Bar		
1/2"	5,000	345	16,000	1,100	5,000	345	22,000	1,500	5,000	15 GPM
3/4"	5,000	345	16,500	1,150	5,000	345	21,500	1,450	5,000	29 GPM
1"	5,000	345	16,000	1,100	5,000	345	15,000	1,000	5,000	50 GPM

## H-BOP Series Hydraulic Couplings

**NEW** 2014

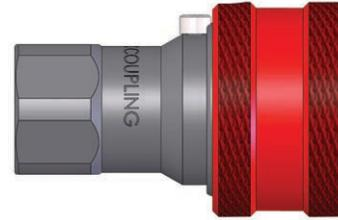
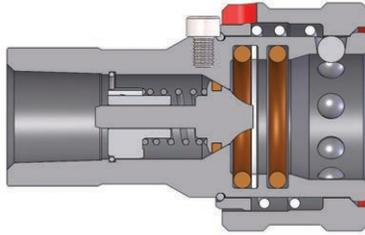

Body Size	H-BOP Series Blowout Prevention Safety Coupler (Female Threads)											
	Part Detail			List Price	Length		Maximum OD		Hex mm	Weight Lb	Package Qty	
	Part Number	Threads	Material		Inch	mm	Inch	mm			Bag	Box
1/2"	4HF4-BOP	1/2" - 14 NPTF	steel	<b>\$105.46</b>	2.86	72.6	1.86	47.2	1-5/16"	0.73	-	25
1/2"	4HF4-SS-BOP	1/2" - 14 NPTF	316 stainless	<b>339.26</b>	2.86	72.6	1.86	47.2	1-5/16"	0.76	-	25
3/4"	6HF6-BOP	3/4" - 14 NPTF	steel	<b>121.42</b>	3.55	90.2	2.22	56.4	1-5/16"	1.30	-	10
3/4"	6HF6-SS-BOP	3/4" - 14 NPTF	316 stainless	<b>512.51</b>	3.55	90.2	2.22	56.4	1-5/16"	1.33	-	10
1"	8HF8-BOP	1" - 11 1/2 NPTF	steel	<b>154.08</b>	4.13	104.9	2.49	63.2	1-5/8"	1.95	-	10
1"	8HF8-SS-BOP	1" - 11 1/2 NPTF	316 stainless	<b>779.59</b>	4.13	104.9	2.49	63.2	1-5/8"	1.95	-	10

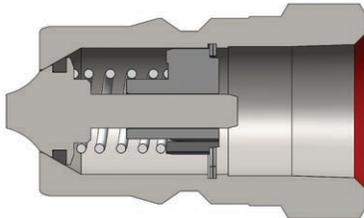

Body Size	H-BOP Series Blowout Prevention Safety Nipple (Female Threads)											
	Part Detail			List Price	Length		Maximum OD		Hex mm	Weight Lb	Package Qty	
	Part Number	Threads	Material		Inch	mm	Inch	mm			Bag	Box
1/2"	H4F4-BOP	1/2" - 14 NPTF	steel	<b>\$65.04</b>	1.94	49.3	1.17	29.7	1-1/16"	0.24	-	25
1/2"	H4F4-SS-BOP	1/2" - 14 NPTF	316 stainless	<b>158.80</b>	1.94	49.3	1.17	29.7	1-1/16"	0.24	-	25
3/4"	H6F6-BOP	3/4" - 14 NPTF	steel	<b>78.35</b>	2.41	61.2	1.44	36.6	1-5/16"	0.46	-	10
3/4"	H6F6-SS-BOP	3/4" - 14 NPTF	316 stainless	<b>223.76</b>	2.41	61.2	1.44	36.6	1-5/16"	0.46	-	10
1"	H8F8-BOP	1" - 11 1/2 NPTF	steel	<b>103.04</b>	2.87	72.9	1.79	45.5	1-5/8"	0.76	-	10
1"	H8F8-SS-BOP	1" - 11 1/2 NPTF	316 stainless	<b>353.70</b>	2.87	72.9	1.79	45.5	1-5/8"	0.76	-	10

# E-Series Hydraulic Couplings

## Interchange Data:

- Straight-Through Pressure-Wash Interchange
- Parker ST-Series, Foster FST-Series, Tomco Series-ST, Hansen ST-Series

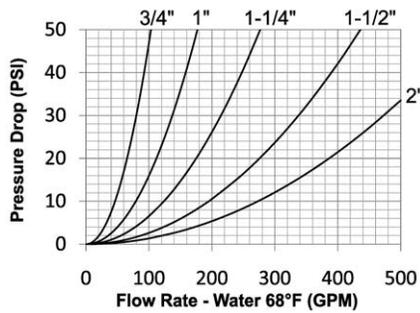
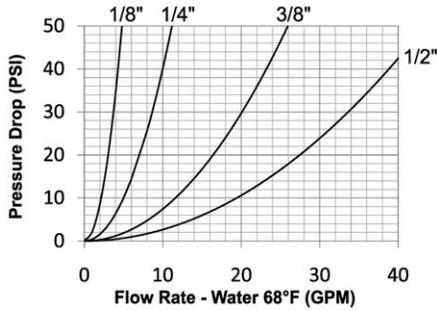

## Seal Components:

- Nitrile (Buna-N) seals are standard, providing a temperature range of -40°F to +250°F (-40°C to +121°C).

## Materials:

- Machined components are manufactured using solid steel, brass, or 303 stainless steel bar stock.
- Stainless steel balls, retaining rings, and springs maximize corrosion resistance and extend service life.
- Steel componentry is plated using ROHS Compliant Trivalent Chrome.
- 1 1/4" to 2" brass couplers have steel sleeves as standard to maximize service life, hardened to resist deformation.
- Steel nipples are hardened to provide heavy duty performance.

## Rated Pressure Chart:

Body Size	E-Series Straight-Through Interchange (Connected)															
	Brass Coupler/Steel Plug				Brass Coupler/Plug				Brass Coupler/303 SS Plug				303 SS Coupler/Plug			
	Max. Working		Burst		Max. Working		Burst		Max. Working		Burst		Max. Working		Burst	
	PSI	Bar	PSI	Bar	PSI	Bar	PSI	Bar	PSI	Bar	PSI	Bar	PSI	Bar	PSI	Bar
1/8"	4,000	276	16,100	1110	2,800	193	11,800	814	4,000	276	20,000	1379	5,000	345	29,900	2062
1/4"	5,500	379	22,000	1517	3,800	262	15,300	1055	5,500	379	23,500	1621	7,500	517	33,800	2331
3/8"	4,500	310	18,300	1262	3,000	207	14,100	972	4,500	310	21,200	1462	7,500	517	34,400	2372
1/2"	3,500	241	13,900	960	2,400	166	9,700	669	3,500	241	14,000	966	3,500	241	14,000	966
3/4"	3,100	207	12,900	870	2,000	138	8,700	600	2,500	172	12,500	862	3,000	207	19,400	1338
1"	2,500	172	10,100	697	1,600	110	6,700	462	2,000	138	8,800	607	2,000	138	9,100	628
1-1/4"	2,500	172	12,600	870	1,800	124	7,500	517	1,800	124	7,500	517	2,000	138	10,000	690
1-1/2"	2,500	172	10,000	690	1800	124	7,500	517	1,800	124	7,500	517	2,000	138	12,000	828
2"	2,500	172	10,000	690	1800	124	7,500	517	1,800	124	5,500	379	2,000	138	9,000	621

## Technical Specifications:

Body Size	Interchange Standards				Functional Parameters				
	U.S. Military	U.S. Government	International Standards	ANSI/NFPA Standards	Locking Ball Quantity	Air Inclusion	Fluid Loss	Vacuum Inch HG	Flow ΔP = 15 PSI
1/8"	-	-	-	-	6	N/A	N/A	N/R	3 GPM
1/4"	-	-	-	-	6	N/A	N/A	N/R	6 GPM
3/8"	-	-	-	-	8	N/A	N/A	N/R	14 GPM
1/2"	-	-	-	-	8	N/A	N/A	N/R	24 GPM
3/4"	-	-	-	-	8	N/A	N/A	N/R	58 GPM
1"	-	-	-	-	8	N/A	N/A	N/R	100 GPM
1-1/4"	-	-	-	-	8	N/A	N/A	N/R	150 GPM
1-1/2"	-	-	-	-	8	N/A	N/A	N/R	250 GPM
2"	-	-	-	-	8	N/A	N/A	N/R	350 GPM

## E-Series Hydraulic Couplings

### List Price Option Adders:

Body Size	Standard Seal Options								Kalrez® Seal Options						Other Options			
	FKM		EPDM		Mil-Nitrile		Silicone		4079		6375		7075		Sleeve-Lock		Oxy-Clean	
	Pre	Add \$	Pre	Add \$	Pre	Add \$	Pre	Add \$	Pre	Add \$	Pre	Add \$	Pre	Add \$	Suf	Add \$	Suf	Add \$
1/8"	F-	\$0.00	P-	\$0.00	M-	\$1.80	S-	\$1.80	K4-	N/A	K6-	N/A	K7-	N/A	-LS	\$3.90	-C1	\$12.00
1/4"	F-	0.00	P-	0.00	M-	2.00	S-	2.00	K4-	N/A	K6-	N/A	K7-	N/A	-LS	3.90	-C1	12.00
3/8"	F-	0.00	P-	0.00	M-	2.36	S-	2.36	K4-	N/A	K6-	N/A	K7-	N/A	-LS	4.50	-C1	12.00
1/2"	F-	0.00	P-	0.00	M-	3.19	S-	3.19	K4-	N/A	K6-	N/A	K7-	N/A	-LS	4.50	-C1	12.00
3/4"	F-	0.00	P-	0.00	M-	4.09	S-	4.09	K4-	N/A	K6-	N/A	K7-	N/A	-LS	6.00	-C1	12.00
1"	F-	0.00	P-	0.00	M-	5.16	S-	5.16	K4-	N/A	K6-	N/A	K7-	N/A	-LS	9.80	-C1	14.00
1-1/4"	F-	0.00	P-	0.00	M-	7.24	S-	7.24	K4-	N/A	K6-	N/A	K7-	N/A	-LS	10.30	-C1	14.00
1-1/2"	F-	0.00	P-	0.00	M-	8.73	S-	8.73	K4-	N/A	K6-	N/A	K7-	N/A	-LS	10.30	-C1	16.00
2"	F-	0.00	P-	0.00	M-	9.54	S-	9.54	K4-	N/A	K6-	N/A	K7-	N/A	-LS	14.60	-C1	20.00

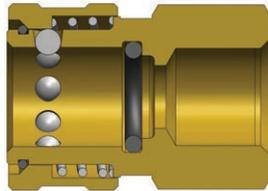

Body Size	E-Series Straight-Through Interchange Coupler (Female Threads)											
	Part Detail			List Price	Length		Maximum OD		Hex Inch	Weight Lb	Package Qty	
	Part Number	Threads	Material		Inch	mm	Inch	mm			Bag	Box
1/8"	1EF1-B	1/8" - 27 NPTF	brass	\$8.37	1.01	25.7	0.65	16.5	9-16"	0.06	250	500
1/8"	1EF1-S	1/8" - 27 NPTF	303 stainless	38.88	1.01	25.7	0.65	16.5	9/16"	0.05	250	500
1/4"	2EF2-B	1/4" - 18 NPTF	brass	8.37	1.40	35.6	0.96	24.4	13/16"	0.17	50	200
1/4"	2EF2-S	1/4" - 18 NPTF	303 stainless	42.81	1.40	35.6	0.96	24.4	13/16"	0.15	50	200
1/4"	2EBF2-B	1/4" - 19 BSPP	brass	9.57	1.40	35.6	0.96	24.4	13/16"	0.17	50	200
3/8"	3EF3-B	3/8" - 18 NPTF	brass	10.33	1.60	40.6	1.13	28.7	1"	0.26	50	200
3/8"	3EF3-S	3/8" - 18 NPTF	303 stainless	56.68	1.60	40.6	1.13	28.7	1"	0.24	50	200
3/8"	3EBF3-B	3/8" - 19 BSPP	brass	10.92	1.60	40.6	1.13	28.7	1"	0.26	50	200
1/2"	4EF4-B	1/2" - 14 NPTF	brass	14.91	1.96	49.8	1.27	32.3	1-1/8"	0.39	25	100
1/2"	4EF4-S	1/2" - 14 NPTF	303 stainless	64.94	1.96	49.8	1.27	32.3	1-1/8"	0.37	25	100
1/2"	4EBF4-B	1/2" - 14 BSPP	brass	17.21	1.96	49.8	1.27	32.3	1-1/8"	0.39	25	100
3/4"	6EF6-B	3/4" - 14 NPTF	brass	28.69	2.10	53.3	1.65	41.9	1-1/2"	0.62	15	60
3/4"	6EF6-S	3/4" - 14 NPTF	303 stainless	113.35	2.10	53.3	1.65	41.9	1-1/2"	0.57	15	60
3/4"	6EBF6-B	3/4" - 14 BSPP	brass	29.54	2.10	53.3	1.65	41.9	1-1/2"	0.62	15	60
1"	8EF8-B	1" - 11 1/2 NPTF	brass	41.30	2.36	59.9	2.02	51.3	1-3/4"	0.99	15	30
1"	8EF8-S	1" - 11 1/2 NPTF	303 stainless	165.30	2.36	59.9	2.02	51.3	1-3/4"	0.93	15	30
1"	8EBF8-B	1" - 11 BSPP	brass	45.02	2.36	59.9	2.02	51.3	1-3/4"	0.99	15	30
1-1/4"	10EF10-B	1-1/4" - 11 1/2 NPTF	brass	111.56	2.36	59.9	2.59	65.8	2-1/4"	1.38	-	10
1-1/4"	10EF10-S	1-1/4" - 11 1/2 NPTF	303 stainless	294.22	2.36	59.9	2.59	65.8	2-1/4"	1.38	-	10
1-1/2"	12EF12-B	1-1/2" - 11 1/2 NPTF	brass	152.90	2.89	73.4	3.18	80.8	2-3/4"	1.42	-	5
1-1/2"	12EF12-S	1-1/2" - 11 1/2 NPTF	303 stainless	426.11	2.89	73.4	3.18	80.8	2-3/4"	1.42	-	5
2"	16EF16-B	2" - 11 1/2 NPTF	brass	210.64	3.00	76.2	4.04	102.6	3-1/2"	4.70	-	1
2"	16EF16-S	2" - 11 1/2 NPTF	303 stainless	507.29	3.00	76.2	4.04	102.6	3-1/2"	4.72	-	1

## E-Series Hydraulic Couplings

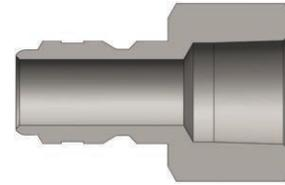

Body Size	E-Series Straight-Through Interchange Nipple (Female Threads)											
	Part Detail			List Price	Length		Maximum OD		Hex Inch	Weight Lb	Package Qty	
	Part Number	Threads	Material		Inch	mm	Inch	mm			Bag	Box
1/8"	E1F1	1/8" - 27 NPTF	steel	\$3.31	0.98	24.9	0.65	16.5	9/16"	0.03	250	500
1/8"	E1F1-B	1/8" - 27 NPTF	brass	2.75	0.98	24.9	0.65	16.5	9/16"	0.03	250	500
1/8"	E1F1-S	1/8" - 27 NPTF	303 stainless	19.60	0.98	24.9	0.65	16.5	9/16"	0.02	250	500
1/4"	E2F2	1/4" - 18 NPTF	steel	2.77	1.47	37.3	0.79	20.1	11/16"	0.07	50	200
1/4"	E2F2-B	1/4" - 18 NPTF	brass	2.99	1.47	37.3	0.79	20.1	11/16"	0.07	50	200
1/4"	E2F2-S	1/4" - 18 NPTF	303 stainless	17.29	1.47	37.3	0.79	20.1	11/16"	0.07	50	200
1/4"	E2BF2-B	1/4" - 19 BSPP	brass	3.49	1.47	37.3	0.79	20.1	11/16"	0.07	50	200
3/8"	E3F3	3/8" - 18 NPTF	steel	4.37	1.60	40.6	1.01	25.7	7/8"	0.11	50	200
3/8"	E3F3-B	3/8" - 18 NPTF	brass	3.50	1.60	40.6	1.01	25.7	7/8"	0.12	50	200
3/8"	E3F3-S	3/8" - 18 NPTF	303 stainless	23.62	1.60	40.6	1.01	25.7	7/8"	0.12	50	200
3/8"	E3BF3-B	3/8" - 19 BSPP	brass	4.50	1.60	40.6	1.01	25.7	7/8"	0.12	50	200
1/2"	E4F4	1/2" - 14 NPTF	steel	6.14	1.82	46.2	1.16	29.5	1"	0.21	35	140
1/2"	E4F4-B	1/2" - 14 NPTF	brass	6.31	1.82	46.2	1.16	29.5	1"	0.23	35	140
1/2"	E4F4-S	1/2" - 14 NPTF	303 stainless	33.54	1.82	46.2	1.16	29.5	1"	0.23	35	140
1/2"	E4BF4-B	1/2" - 14 BSPP	brass	6.76	1.82	46.2	1.16	29.5	1"	0.23	35	140
3/4"	E6F6	3/4" - 14 NPTF	steel	14.17	2.05	52.1	1.37	34.8	1-3/16"	0.32	25	100
3/4"	E6F6-B	3/4" - 14 NPTF	brass	11.25	2.05	52.1	1.37	34.8	1-3/16"	0.32	25	100
3/4"	E6F6-S	3/4" - 14 NPTF	303 stainless	44.87	2.05	52.1	1.37	34.8	1-3/16"	0.32	25	100
3/4"	E6BF6-B	3/4" - 14 BSPP	brass	16.07	2.05	52.1	1.37	34.8	1-3/16"	0.32	25	100
1"	E8F8	1" - 11 1/2 NPTF	steel	26.56	2.36	59.9	1.73	43.9	1-1/2"	0.49	25	50
1"	E8F8-B	1" - 11 1/2 NPTF	brass	24.09	2.36	59.9	1.73	43.9	1-1/2"	0.52	25	50
1"	E8F8-S	1" - 11 1/2 NPTF	303 stainless	82.66	2.36	59.9	1.73	43.9	1-1/2"	0.52	25	50
1"	E8BF8-B	1" - 11 BSPP	brass	27.02	2.36	59.9	1.73	43.9	1-1/2"	0.49	25	50
1-1/4"	E10F10	1-1/4" - 11 1/2 NPTF	steel	61.96	2.47	62.7	2.31	58.7	2"	0.85	-	10
1-1/4"	E10F10-B	1-1/4" - 11 1/2 NPTF	brass	54.02	2.47	62.7	2.31	58.7	2"	0.85	-	10
1-1/4"	E10F10-S	1-1/4" - 11 1/2 NPTF	303 stainless	139.00	2.47	62.7	2.31	58.7	2"	0.85	-	10
1-1/2"	E12F12	1-1/2" - 11 1/2 NPTF	steel	99.61	2.74	69.6	2.60	66.0	2-1/4"	1.45	-	5
1-1/2"	E12F12-B	1-1/2" - 11 1/2 NPTF	brass	87.79	2.74	69.6	2.60	66.0	2-1/4"	1.45	-	5
1-1/2"	E12F12-S	1-1/2" - 11 1/2 NPTF	303 stainless	243.24	2.74	69.6	2.60	66.0	2-1/4"	1.45	-	5
2"	E16F16	2" - 11 1/2 NPTF	steel	127.41	3.00	76.2	3.03	77.0	2-5/8"	1.90	-	1
2"	E16F16-B	2" - 11 1/2 NPTF	brass	119.30	3.00	76.2	3.03	77.0	2-5/8"	1.90	-	1
2"	E16F16-S	2" - 11 1/2 NPTF	303 stainless	312.74	3.00	76.2	3.03	77.0	2-5/8"	1.90	-	1



## E-Series Hydraulic Couplings

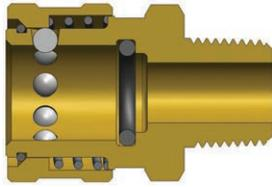

Body Size	E-Series Straight-Through Interchange Coupler (Male Threads)											
	Part Detail			List Price	Length		Maximum OD		Hex Inch	Weight Lb	Package Qty	
	Part Number	Threads	Material		Inch	mm	Inch	mm			Bag	Box
1/8"	1EM1-B	1/8" - 27 NPTF	brass	\$8.37	1.01	25.7	0.65	16.5	9-16"	0.06	250	500
1/8"	1EM1-S	1/8" - 27 NPTF	303 stainless	38.88	1.01	25.7	0.65	16.5	9/16"	0.05	250	500
1/4"	2EM2-B	1/4" - 18 NPTF	brass	8.37	1.66	42.2	0.96	24.4	13/16"	0.17	50	200
1/4"	2EM2-S	1/4" - 18 NPTF	303 stainless	42.81	1.66	42.2	0.96	24.4	13/16"	0.15	50	200
3/8"	3EM3-B	3/8" - 18 NPTF	brass	10.33	1.70	43.2	1.13	28.7	1"	0.26	50	200
3/8"	3EM3-S	3/8" - 18 NPTF	303 stainless	56.68	1.70	43.2	1.13	28.7	1"	0.24	50	200
1/2"	4EM4-B	1/2" - 14 NPTF	brass	14.91	2.00	50.8	1.27	32.3	1-1/8"	0.39	25	100
1/2"	4EM4-S	1/2" - 14 NPTF	303 stainless	64.94	2.00	50.8	1.27	32.3	1-1/8"	0.37	25	100
3/4"	6EM6-B	3/4" - 14 NPTF	brass	28.69	2.24	56.9	1.65	41.9	1-1/2"	0.62	15	60
3/4"	6EM6-S	3/4" - 14 NPTF	303 stainless	113.35	2.24	56.9	1.65	41.9	1-1/2"	0.57	15	60
1"	8EM8-B	1" - 11 1/2 NPTF	brass	41.30	2.61	66.3	2.02	51.3	1-3/4"	0.99	15	30
1"	8EM8-S	1" - 11 1/2 NPTF	303 stainless	165.30	2.61	66.3	2.02	51.3	1-3/4"	0.93	15	30
1-1/4"	10EM10-B	1-1/4" - 11 1/2 NPTF	brass	111.56	2.91	73.9	2.59	65.8	2-1/4"	1.64	-	10
1-1/2"	12EM12-B	1-1/2" - 11 1/2 NPTF	brass	152.90	3.44	87.4	3.18	80.8	2-3/4"	2.04	-	5
2"	16EM16-B	2" - 11 1/2 NPTF	brass	210.64	3.70	94.0	4.04	102.6	3-1/2"	3.16	-	1

### E Series Profiles

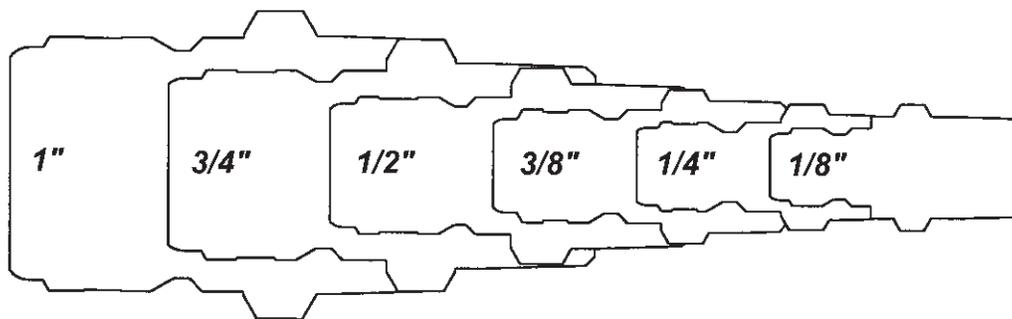

## E-Series Hydraulic Couplings

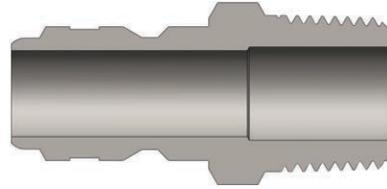

Body Size	E-Series Straight-Through Interchange Nipple (Male Threads)											
	Part Detail			List Price	Length		Maximum OD		Hex Inch	Weight Lb	Package Qty	
	Part Number	Threads	Material		Inch	mm	Inch	mm			Bag	Box
1/8"	E1M1	1/8" - 27 NPTF	steel	\$3.78	1.15	29.2	0.58	14.7	1/2"	0.02	250	500
1/8"	E1M1-B	1/8" - 27 NPTF	brass	2.75	1.15	29.2	0.58	14.7	1/2"	0.02	250	500
1/8"	E1M1-S	1/8" - 27 NPTF	303 stainless	19.60	1.15	29.2	0.58	14.7	1/2"	0.02	250	500
1/4"	E2M2	1/4" - 18 NPTF	steel	2.77	1.50	38.1	0.65	16.5	9/16"	0.05	50	200
1/4"	E2M2-B	1/4" - 18 NPTF	brass	2.99	1.50	38.1	0.65	16.5	9/16"	0.06	50	200
1/4"	E2M2-S	1/4" - 18 NPTF	303 stainless	17.29	1.50	38.1	0.65	16.5	9/16"	0.05	50	200
3/8"	E3M3	3/8" - 18 NPTF	steel	4.37	1.69	42.9	0.79	20.1	11/16"	0.07	50	200
3/8"	E3M3-B	3/8" - 18 NPTF	brass	3.50	1.69	42.9	0.79	20.1	11/16"	0.08	50	200
3/8"	E3M3-S	3/8" - 18 NPTF	303 stainless	23.62	1.69	42.9	0.79	20.1	11/16"	0.08	50	200
1/2"	E4M4	1/2" - 14 NPTF	steel	6.14	1.91	48.5	1.01	25.7	7/8"	0.13	35	140
1/2"	E4M4-B	1/2" - 14 NPTF	brass	6.31	1.91	48.5	1.01	25.7	7/8"	0.15	35	140
1/2"	E4M4-S	1/2" - 14 NPTF	303 stainless	33.54	1.91	48.5	1.01	25.7	7/8"	0.13	35	140
3/4"	E6M6	3/4" - 14 NPTF	steel	14.17	2.25	57.2	1.23	31.2	1-1/16"	0.21	25	100
3/4"	E6M6-B	3/4" - 14 NPTF	brass	11.25	2.25	57.2	1.23	31.2	1-1/16"	0.23	25	100
3/4"	E6M6-S	3/4" - 14 NPTF	303 stainless	44.87	2.25	57.2	1.23	31.2	1-1/16"	0.22	25	100
1"	E8M8	1" - 11 1/2 NPTF	steel	26.56	2.45	62.2	1.59	40.4	1-3/8"	0.43	25	50
1"	E8M8-B	1" - 11 1/2 NPTF	brass	24.09	2.45	62.2	1.59	40.4	1-3/8"	0.48	25	50
1"	E8M8-S	1" - 11 1/2 NPTF	303 stainless	82.66	2.45	62.2	1.59	40.4	1-3/8"	0.43	25	50
1-1/4"	E10M10	1-1/4" - 11 1/2 NPTF	steel	69.49	2.80	71.1	2.02	51.3	1-3/4"	0.96	-	10
1-1/4"	E10M10-B	1-1/4" - 11 1/2 NPTF	brass	61.90	2.80	71.1	2.02	51.3	1-3/4"	0.96	-	10
1-1/2"	E12M12	1-1/2" - 11 1/2 NPTF	steel	99.61	3.38	85.9	2.60	66.0	2-1/4"	1.46	-	5
1-1/2"	E12M12-B	1-1/2" - 11 1/2 NPTF	brass	87.79	3.38	85.9	2.60	66.0	2-1/4"	1.46	-	5
2"	E16M16	2" - 11 1/2 NPTF	steel	133.20	3.58	90.9	3.03	77.0	2-5/8"	1.54	-	1
2"	E16M16-B	2" - 11 1/2 NPTF	brass	120.43	3.58	90.9	3.03	77.0	2-5/8"	1.50	-	1

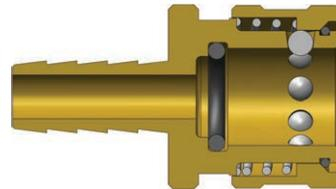
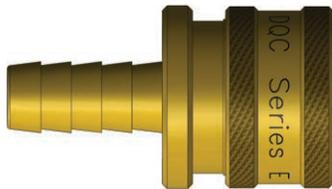

Body Size	E-Series Straight-Through Interchange Coupler (Hose Barb)											
	Part Detail			List Price	Length		Maximum OD		Hex Inch	Weight Lb	Package Qty	
	Part Number	Hose ID	Material		Inch	mm	Inch	mm			Bag	Box
1/4"	2ES2-B	1/4"	brass	\$12.45	1.87	47.5	0.96	24.4	-	0.16	50	200
3/8"	3ES3-B	3/8"	brass	13.77	1.87	47.5	1.13	28.7	-	0.21	50	200
1/2"	4ES4-B	1/2"	brass	22.37	2.90	73.7	1.27	32.3	-	0.31	25	100
3/4"	6ES6-B	3/4"	brass	34.42	3.16	80.3	1.63	41.4	-	0.49	15	60
1"	8ES8-B	1"	brass	47.04	3.25	82.6	2.02	51.3	-	0.68	15	30

## E-Series Hydraulic Couplings

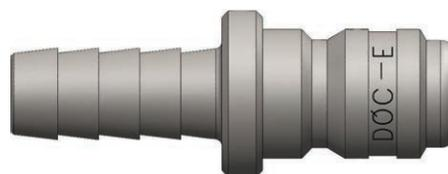
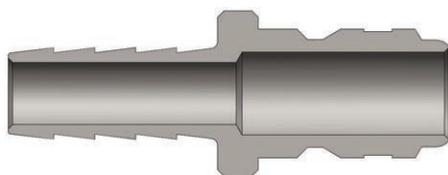

Body Size	E-Series Straight-Through Interchange Nipple (Hose Barb)											
	Part Detail			List Price	Length		Maximum OD		Hex Inch	Weight Lb	Package Qty	
	Part Number	Hose ID	Material		Inch	mm	Inch	mm			Bag	Box
1/4"	E2S2	1/4"	steel	<b>\$6.03</b>	1.90	48.3	0.56	14.2	-	0.05	50	200
1/4"	E2S2-B	1/4"	brass	<b>5.16</b>	1.90	48.3	0.56	14.2	-	0.06	50	200
3/8"	E3S3	3/8"	steel	<b>7.80</b>	2.03	51.6	0.63	16.0	-	0.08	50	200
3/8"	E3S3-B	3/8"	brass	<b>6.31</b>	2.03	51.6	0.63	16.0	-	0.08	50	200
1/2"	E4S4	1/2"	steel	<b>14.65</b>	2.09	53.1	0.75	19.1	-	0.13	35	140
1/2"	E4S4-B	1/2"	brass	<b>12.05</b>	2.09	53.1	0.75	19.1	-	0.13	35	140
3/4"	E6S6	3/4"	steel	<b>18.53</b>	2.28	57.9	1.13	28.7	-	0.21	25	100
3/4"	E6S6-B	3/4"	brass	<b>15.78</b>	2.28	57.9	1.13	28.7	-	0.21	25	100
1"	E8S8	1"	steel	<b>37.07</b>	3.28	83.3	1.38	35.1	-	0.43	25	50
1"	E8S8-B	1"	brass	<b>34.42</b>	3.28	83.3	1.38	35.1	-	0.43	25	50

Body Size	E-Series Straight-Through Interchange Coupler Seal Kits						
	Part Detail			List Price	Seal Kit Contents	Package Qty	
	Part Number	Coupler Style	Seal Material			Bag	Box
1/4"	2E-SKIT	all	Nitrile	<b>\$0.90</b>	Body O-Ring	25	200
1/4"	F-2E-SKIT	all	FKM	<b>1.02</b>	Body O-Ring	25	200
1/4"	P-2E-SKIT	all	EPDM	<b>1.12</b>	Body O-Ring	25	200
3/8"	3E-SKIT	all	Nitrile	<b>0.90</b>	Body O-Ring	25	200
3/8"	F-3E-SKIT	all	FKM	<b>1.02</b>	Body O-Ring	25	200
3/8"	P-3E-SKIT	all	EPDM	<b>1.12</b>	Body O-Ring	25	200
1/2"	4E-SKIT	all	Nitrile	<b>1.13</b>	Body O-Ring	25	200
1/2"	F-4E-SKIT	all	FKM	<b>1.78</b>	Body O-Ring	25	200
1/2"	P-4E-SKIT	all	EPDM	<b>1.78</b>	Body O-Ring	25	200
3/4"	6E-SKIT	all	Nitrile	<b>1.18</b>	Body O-Ring	25	200
3/4"	F-6E-SKIT	all	FKM	<b>1.87</b>	Body O-Ring	25	200
3/4"	P-6E-SKIT	all	EPDM	<b>1.87</b>	Body O-Ring	25	200
1"	8E-SKIT	all	Nitrile	<b>1.63</b>	Body O-Ring	25	200
1"	F-8E-SKIT	all	FKM	<b>2.01</b>	Body O-Ring	25	200
1"	P-8E-SKIT	all	EPDM	<b>2.01</b>	Body O-Ring	25	200
1-1/4"	10E-SKIT	all	Nitrile	<b>1.63</b>	Body O-Ring	25	-
1-1/4"	F-10E-SKIT	all	FKM	<b>2.28</b>	Body O-Ring	25	-
1-1/4"	P-10E-SKIT	all	EPDM	<b>2.28</b>	Body O-Ring	25	-
1-1/2"	12E-SKIT	all	Nitrile	<b>2.04</b>	Body O-Ring	25	-
1-1/2"	F-12E-SKIT	all	FKM	<b>2.50</b>	Body O-Ring	25	-
1-1/2"	P-12E-SKIT	all	EPDM	<b>2.50</b>	Body O-Ring	25	-
2"	16E-SKIT	all	Nitrile	<b>3.22</b>	Body O-Ring	25	-
2"	F-16E-SKIT	all	FKM	<b>3.05</b>	Body O-Ring	25	-
2"	P-16E-SKIT	all	EPDM	<b>3.05</b>	Body O-Ring	25	-

# EA-Series Hydraulic Couplings

### Interchange Data:

- Water-Blast Interchange
- Parker Series-WB, Aeroquip FD69, Snap-Tite 56-Series

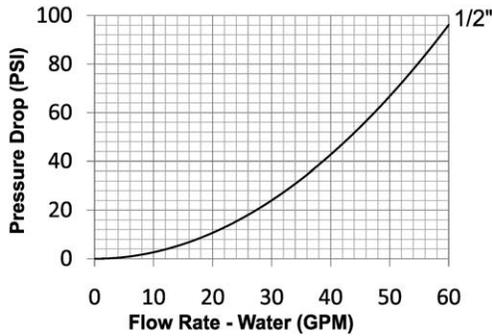

### Seal Components:

- Nitrile (Buna-N) seals are standard, providing a temperature range of -40°F to +250°F (-40°C to +121°C).
- Couplers have a PTFE Anti-Extrusion ring, providing resistance to O-Ring dynamic impulse pressure damage.

### Materials:

- Machined components are manufactured using solid high strength steel bar stock.
- Stainless steel springs and retaining rings maximize corrosion resistance and extend service life.
- Latches are manufactured from high-strength steel and plated with electroless nickel.
- Steel nipples are machined from solid high strength steel bar stock and hardened.
- Machined steel componentry is plated using ROHS Compliant Trivalent Chrome.

### Rated Pressure Chart:

Body Size	EA-Series Water-Blast Interchange (Connected)			
	Coupler/Plug			
	Maximum Working		Burst	
	PSI	Bar	PSI	Bar
1/2"	10,000	700	30,000	2,100

### Technical Specifications:

Body Size	Interchange Standards				Functional Parameters				
	U.S. Military	U.S. Government	International Standards	ANSI/NFPA Standards	Locking Mechanism	Air Inclusion	Fluid Loss	Vacuum Inch HG	Flow $\Delta P = 40$ PSI
1/2"	-	-	-	-	Maxi-Latch	N/A	N/A	N/R	40 GPM

### List Price Option Adders:

Body Size	Standard Seal Options										Kalrez® Seal Options						Other Options			
	FKM		EPDM		FDA FKM		Mil-Nitrile		Silicone		4079		6375		7075		No Pin-Lock		Oxy-Clean	
	Pre	Add \$	Pre	Add \$	Pre	Add \$	Pre	Add \$	Pre	Add \$	Pre	Add \$	Pre	Add \$	Pre	Add \$	Suf	Add \$	Suf	Add \$
1/2"	F-	\$0.00	P-	\$4.00	D-	\$5.20	M-	\$3.60	S-	\$4.50	K4-	POR	K6-	POR	K7-	POR	-NL	-\$5.20	-C1	\$12.00

## EA-Series Hydraulic Couplings

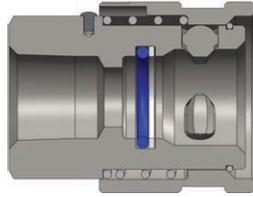

Body Size	EA-Series Water-Blast Interchange Coupler (Female Threads)											
	Part Detail			List Price	Length		Maximum OD		Hex Inch	Weight Lb	Package Qty	
	Part Number	Threads	Material		Inch	mm	Inch	mm			Bag	Box
1/2"	4EAF3	3/8" - 18 NPTF	steel	\$125.17	2.20	55.9	1.62	41.1	1-1/4"	0.68	5	25
1/2"	4EAF4	1/2" - 14 NPTF	steel	125.17	2.20	55.9	1.62	41.1	1-1/4"	0.65	5	25

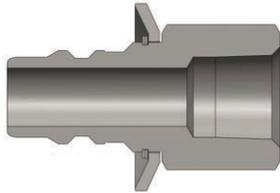

Body Size	EA-Series Water-Blast Interchange Nipple (Female Threads)											
	Part Detail			List Price	Length		Maximum OD		Hex Inch	Weight Lb	Package Qty	
	Part Number	Threads	Material		Inch	mm	Inch	mm			Bag	Box
1/2"	EA4F3	3/8" - 18 NPTF	steel	\$27.06	2.35	59.7	1.62	41.1	1-1/8"	0.38	5	25
1/2"	EA4F4	1/2" - 14 NPTF	steel	33.86	2.35	59.7	1.62	41.1	1-1/8"	0.34	5	25

Body Size	E-Series Water-Blast Interchange Coupler Seal Kits							
	Part Detail			List Price	Seal Kit		Package Qty	
	Part Number	Coupler Style	Seal Material		Contents		Bag	Box
1/2"	4EA-SKIT	all	Nitrile	\$5.47	Body O-Ring and PTFE Back-up		25	200
1/2"	F-4EA-SKIT	all	FKM	6.46	Body O-Ring and PTFE Back-up		25	200
1/2"	P-4EA-SKIT	all	EPDM	6.46	Body O-Ring and PTFE Back-up		25	200

### EA Profile

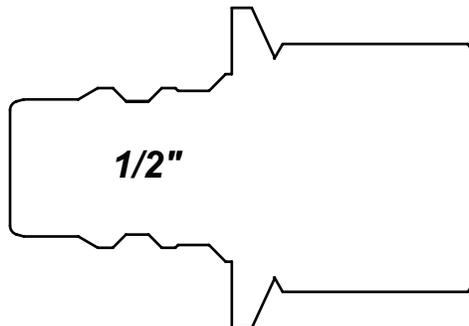

# CM-Series Hydraulic Couplings

## Interchange Data:

- Mold Coolant Interchange  
Foster Series-FJT, Hansen Flo-Temp, Tomco MC-Series  
Parker Moldmate, DME Jiffy-Tite

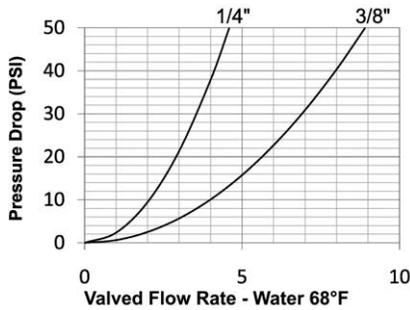
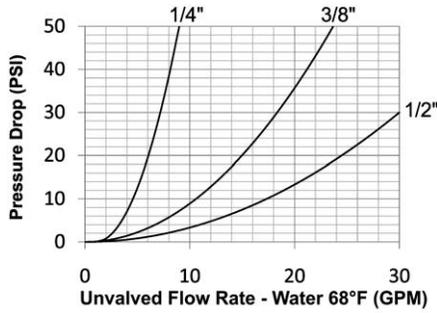

## Seal Components:

- Silicon gaskets and valve O-rings are standard, providing a temperature range of -90°F to +400°F (-68°C to +205°C).

## Materials:

- Machined components are manufactured using solid steel or brass bar stock.
- Stainless steel balls, retaining rings, and springs maximize corrosion resistance and extend service life.
- Steel componentry is plated using ROHS Compliant Trivalent Chrome.

## CM Series Profiles

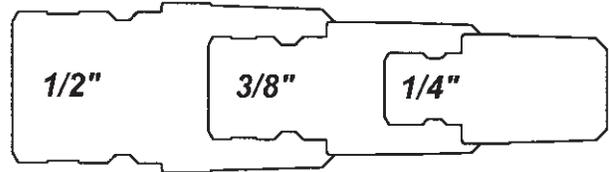

## Rated Pressure Chart:

Body Size	CM-Series Industrial Mold Interchange (Connected)															
	Unvalved Coupler/Brass Plug				Unvalved Coupler/Steel Plug				Valved Coupler/Brass Plug				Valved Coupler/Steel Plug			
	Max. Working		Burst		Max. Working		Burst		Max. Working		Burst		Max. Working		Burst	
	PSI	Bar	PSI	Bar	PSI	Bar	PSI	Bar	PSI	Bar	PSI	Bar	PSI	Bar	PSI	Bar
1/4"	300	20	10,000	700	500	35	10,700	750	300	20	6,000	400	300	20	6,100	400
3/8"	300	20	14,500	1,000	500	35	14,200	1,000	300	20	6,700	450	300	20	6,100	400
1/2"	300	20	4,900	340	-	-	-	-	-	-	-	-	-	-	-	-

## Technical Specifications:

Body Size	Interchange Standards				Functional Parameters				
	U.S. Military	U.S. Government	International Standards	ANSI/NFPA Standards	Locking Ball Quantity	Air Inclusion	Fluid Loss	Vacuum Inch HG	Flow $\Delta P = 7$ PSI
1/4"	-	-	-	-	6	N/A	N/A	N/R	3 GPM
3/8"	-	-	-	-	8	N/A	N/A	N/R	9 GPM
1/2"	-	-	-	-	8	N/A	N/A	N/R	15 GPM

## CM-Series Hydraulic Couplings

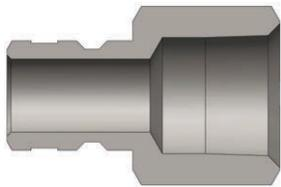

Body Size	CM-Series Industrial Mold Interchange Nipple (Female Threads)											
	Part Detail			List Price	Length		Maximum OD		Hex Inch	Weight Lb	Package Qty	
	Part Number	Threads	Material		Inch	mm	Inch	mm			Bag	Box
1/4"	CM2F1	1/8" - 27 NPTF	steel	<b>\$1.96</b>	0.90	22.9	0.58	14.7	1/2"	0.02	10	100
1/4"	CM2F1-B	1/8" - 27 NPTF	brass	<b>2.08</b>	0.90	22.9	0.58	14.7	1/2"	0.02	10	100
1/4"	CM2F2	1/4" - 18 NPTF	steel	<b>2.07</b>	1.12	28.4	0.72	18.3	5/8"	0.04	10	100
1/4"	CM2F2-B	1/4" - 18 NPTF	brass	<b>2.22</b>	1.12	28.4	0.72	18.3	5/8"	0.05	10	100
1/4"	CM2F3	3/8" - 18 NPTF	steel	<b>2.59</b>	1.21	30.7	0.87	22.1	3/4"	0.08	10	100
1/4"	CM2F3-B	3/8" - 18 NPTF	brass	<b>2.90</b>	1.21	30.7	0.87	22.1	3/4"	0.08	10	100
3/8"	CM3F2	1/4" - 18 NPTF	steel	<b>2.61</b>	1.34	34.0	0.72	18.3	5/8"	0.05	10	50
3/8"	CM3F2-B	1/4" - 18 NPTF	brass	<b>2.67</b>	1.34	34.0	0.72	18.3	5/8"	0.05	10	50
3/8"	CM3F3	3/8" - 18 NPTF	steel	<b>3.38</b>	1.34	34.0	0.87	22.1	3/4"	0.06	10	50
3/8"	CM3F3-B	3/8" - 18 NPTF	brass	<b>3.78</b>	1.34	34.0	0.87	22.1	3/4"	0.07	10	50
1/2"	CM4F4-B	1/2" - 14 NPTF	brass	<b>7.64</b>	1.69	42.9	1.16	29.5	1"	0.09	5	30
1/2"	CM4F6-B	3/4" - 14 NPTF	brass	<b>10.73</b>	1.69	42.9	1.37	34.8	1-3/16"	0.10	5	30

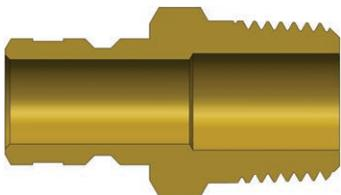

Body Size	CM-Series Industrial Mold Interchange Nipple (Male Threads)											
	Part Detail			List Price	Length		Maximum OD		Hex Inch	Weight Lb	Package Qty	
	Part Number	Threads	Material		Inch	mm	Inch	mm			Bag	Box
1/4"	CM2M1-B	1/8" - 27 NPTF	brass	<b>\$1.57</b>	1.00	25.4	0.65	16.5	9/16"	0.02	10	100
1/4"	CM2M2-B	1/4" - 18 NPTF	brass	<b>1.87</b>	1.15	29.2	0.65	16.5	9/16"	0.03	10	100
1/4"	CM2M3-B	3/8" - 18 NPTF	brass	<b>2.34</b>	1.21	30.7	0.79	20.1	11/16"	0.05	10	100
3/8"	CM3M2-B	1/4" - 18 NPTF	brass	<b>2.15</b>	1.37	34.8	0.65	16.5	9/16"	0.04	10	50
3/8"	CM3M3-B	3/8" - 18 NPTF	brass	<b>2.34</b>	1.43	36.3	0.79	20.1	11/16"	0.00	10	50
3/8"	CM3M4-B	1/2" - 14 NPTF	brass	<b>3.93</b>	1.58	40.1	1.01	25.7	7/8"	0.07	10	50
1/2"	CM4M4-B	1/2" - 14 NPTF	brass	<b>4.56</b>	1.69	42.9	1.01	25.7	7/8"	0.10	5	30
1/2"	CM4M6-B	3/4" - 14 NPTF	brass	<b>6.95</b>	1.79	45.5	1.23	31.2	1-1/16"	0.11	5	30

## CM-Series Hydraulic Couplings



Body Size	CM-Series Industrial Mold Interchange Extension Nipple (Male Threads)											
	Part Detail			List Price	Length		Maximum OD		Hex Inch	Weight Lb	Package Qty	
	Part Number	Threads	Material		Inch	mm	Inch	mm			Bag	Box
1/4"	CM2M1-B-L2.5	1/8" - 27 NPTF	brass	\$8.82	2.50	63.5	0.51	13.0	7/16"	0.06	10	50
1/4"	CM2M1-B-L4	1/8" - 27 NPTF	brass	10.42	4.00	101.6	0.51	13.0	7/16"	0.10	10	50
1/4"	CM2M1-B-L5.5	1/8" - 27 NPTF	brass	14.16	5.50	139.7	0.51	13.0	7/16"	0.13	10	50
1/4"	CM2M2-B-L2.5	1/4" - 18 NPTF	brass	9.65	2.50	63.5	0.65	16.5	9/16"	0.09	10	50
1/4"	CM2M2-B-L4	1/4" - 18 NPTF	brass	11.41	4.00	101.6	0.65	16.5	9/16"	0.15	10	50
1/4"	CM2M2-B-L5.5	1/4" - 18 NPTF	brass	15.12	5.50	139.7	0.65	16.5	9/16"	0.22	10	50
1/4"	CM2M2-B-L7	1/4" - 18 NPTF	brass	17.92	7.00	177.8	0.65	16.5	9/16"	0.27	10	50
3/8"	CM3M1-B-L2.5	1/8" - 27 NPTF	brass	9.65	2.50	63.5	0.65	16.5	9/16"	0.07	5	25
3/8"	CM3M1-B-L4	1/8" - 27 NPTF	brass	11.41	4.00	101.6	0.65	16.5	9/16"	0.11	5	25
3/8"	CM3M1-B-L5.5	1/8" - 27 NPTF	brass	16.05	5.50	139.7	0.65	16.5	9/16"	0.15	5	25
3/8"	CM3M1-B-L7	1/8" - 27 NPTF	brass	17.92	7.00	177.8	0.65	16.5	9/16"	0.18	5	25
3/8"	CM3M2-B-L2.5	1/4" - 18 NPTF	brass	9.65	2.50	63.5	0.65	16.5	9/16"	0.09	5	25
3/8"	CM3M2-B-L4	1/4" - 18 NPTF	brass	11.41	4.00	101.6	0.65	16.5	9/16"	0.15	5	25
3/8"	CM3M2-B-L5.5	1/4" - 18 NPTF	brass	15.12	5.50	139.7	0.65	16.5	9/16"	0.21	5	25
3/8"	CM3M2-B-L7	1/4" - 18 NPTF	brass	17.92	7.00	177.8	0.65	16.5	9/16"	0.27	5	25
3/8"	CM3M2-B-L8.5	1/4" - 18 NPTF	brass	20.21	8.50	215.9	0.65	16.5	9/16"	0.33	5	25
3/8"	CM3M2-B-L11.5	1/4" - 18 NPTF	brass	23.72	11.50	292.1	0.65	16.5	9/16"	0.45	5	25

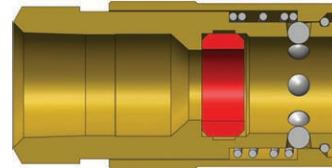

Body Size	CM-Series Industrial Mold Interchange Unvalved Coupler (Female Threads)											
	Part Detail			List Price	Length		Maximum OD		Hex Inch	Weight Lb	Package Qty	
	Part Number	Threads	Material		Inch	mm	Inch	mm			Bag	Box
1/4"	2CMF1-B-E	1/8" - 27 NPTF	brass	\$8.77	1.35	34.3	0.69	17.5	9/16"	0.07	10	100
1/4"	2CMF2-B-E	1/4" - 18 NPTF	brass	9.03	1.35	34.3	0.79	20.1	11/16"	0.08	10	100
3/8"	3CMF2-B-E	1/4" - 18 NPTF	brass	10.88	1.84	46.7	0.95	24.1	3/4"	0.21	10	50
3/8"	3CMF3-B-E	3/8" - 18 NPTF	brass	11.37	1.84	46.7	1.01	25.7	7/8"	0.23	10	50
1/2"	4CMF4-B-E	1/2" - 14 NPTF	brass	25.59	2.02	51.3	1.24	31.5	1-1/8"	0.34	5	30

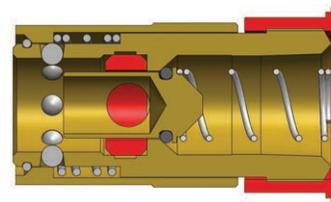

Body Size	CM-Series Industrial Mold Interchange Valved Coupler (Female Threads)											
	Part Detail			List Price	Length		Maximum OD		Hex Inch	Weight Lb	Package Qty	
	Part Number	Threads	Material		Inch	mm	Inch	mm			Bag	Box
1/4"	2CMF1-B	1/8" - 27 NPTF	brass	\$9.89	1.35	34.3	0.69	17.5	9/16"	0.07	10	100
3/8"	3CMF2-B	1/4" - 18 NPTF	brass	14.38	1.84	46.7	0.95	24.1	3/4"	0.21	10	50



## CM-Series Hydraulic Couplings

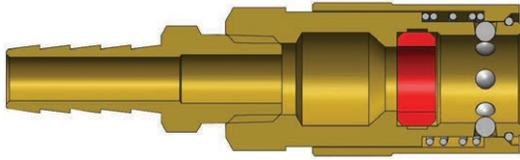

Body Size	CM-Series Industrial Mold Interchange Unvalved Coupler (Hose Barb)											
	Part Detail			List Price	Length		Maximum OD		Hex Inch	Weight Lb	Package Qty	
	Part Number	Hose ID	Material		Inch	mm	Inch	mm			Bag	Box
1/4"	2CMS2-B-E	1/4"	brass	<b>\$10.11</b>	2.11	53.6	0.69	17.5	-	0.10	10	100
1/4"	2CMS2.5-B-E	5/16"	brass	<b>10.11</b>	2.10	53.3	0.69	17.5	-	0.09	10	100
1/4"	2CMS3-B-E	3/8"	brass	<b>10.11</b>	2.10	53.3	0.69	17.5	-	0.11	10	100
3/8"	3CMS3-B-E	3/8"	brass	<b>13.02</b>	2.55	64.8	0.95	24.1	-	0.24	10	50
3/8"	3CMS4-B-E	1/2"	brass	<b>13.02</b>	2.55	64.8	0.95	24.1	-	0.25	10	50
1/2"	4CMS4-B-E	1/2"	brass	<b>29.76</b>	2.98	75.7	1.18	30.0	-	0.46	5	30
1/2"	4CMS6-B-E	3/4"	brass	<b>29.76</b>	2.98	75.7	1.18	30.0	-	0.48	5	30

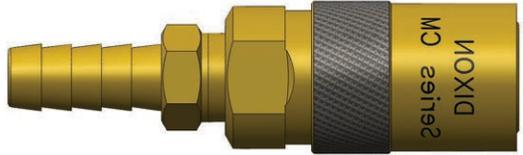
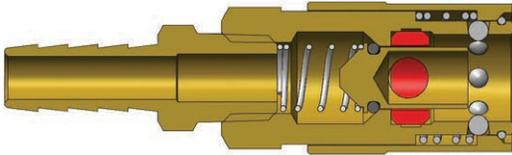

Body Size	CM-Series Industrial Mold Interchange Valved Coupler (Hose Barb)											
	Part Detail			List Price	Length		Maximum OD		Hex Inch	Weight Lb	Package Qty	
	Part Number	Hose ID	Material		Inch	mm	Inch	mm			Bag	Box
1/4"	2CMS2-B	1/4"	brass	<b>\$11.59</b>	2.66	67.6	0.69	17.5	-	0.10	10	100
1/4"	2CMS2.5-B	5/16"	brass	<b>11.68</b>	2.66	67.6	0.69	17.5	-	0.10	10	100
1/4"	2CMS3-B	3/8"	brass	<b>17.17</b>	2.66	67.6	0.69	17.5	-	0.10	10	100
3/8"	3CMS3-B	3/8"	brass	<b>17.50</b>	3.30	83.8	0.95	24.1	-	0.27	10	50
3/8"	3CMS4-B	1/2"	brass	<b>17.50</b>	3.28	83.3	0.95	24.1	-	0.28	10	50

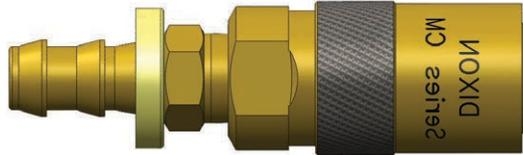
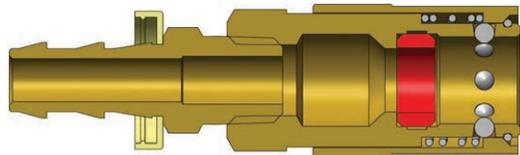

Body Size	CM-Series Industrial Mold Interchange Unvalved Coupler (Push-Loc Barb)											
	Part Detail			List Price	Length		Maximum OD		Hex Inch	Weight Lb	Package Qty	
	Part Number	Hose ID	Material		Inch	mm	Inch	mm			Bag	Box
1/4"	2CMB2-B-E	1/4"	brass	<b>\$11.23</b>	2.08	52.8	0.69	17.5	-	0.10	10	100
1/4"	2CMB3-B-E	3/8"	brass	<b>11.23</b>	2.08	52.8	0.69	17.5	-	0.11	10	100
3/8"	3CMB3-B-E	3/8"	brass	<b>15.16</b>	2.53	64.3	0.95	24.1	-	0.26	10	50
3/8"	3CMB4-B-E	1/2"	brass	<b>15.16</b>	2.69	68.3	0.95	24.1	-	0.25	10	50
1/2"	4CMB4-B-E	1/2"	brass	<b>29.76</b>	3.12	79.2	1.18	30.0	-	0.50	5	30
1/2"	4CMB6-B-E	3/4"	brass	<b>29.76</b>	3.12	79.2	1.18	30.0	-	0.51	5	30

## CM-Series Hydraulic Couplings

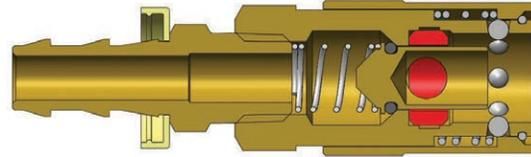
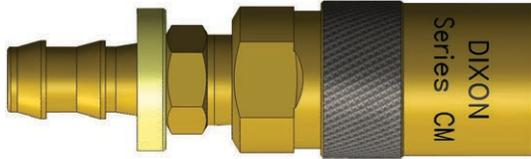

Body Size	CM-Series Industrial Mold Interchange Valved Coupler (Push-Loc Barb)											
	Part Detail			List Price	Length		Maximum OD		Hex Inch	Weight Lb	Package Qty	
	Part Number	Hose ID	Material		Inch	mm	Inch	mm			Bag	Box
1/4"	2CMB2-B	1/4"	brass	\$14.15	2.64	67.1	0.69	17.5	-	0.10	10	100
1/4"	2CMB3-B	3/8"	brass	17.50	2.67	67.8	0.69	17.5	-	0.13	10	100
3/8"	3CMB3-B	3/8"	brass	18.42	3.28	83.3	0.95	24.1	-	0.29	10	50
3/8"	3CMB4-B	1/2"	brass	18.42	3.44	87.4	0.95	24.1	-	0.30	10	50

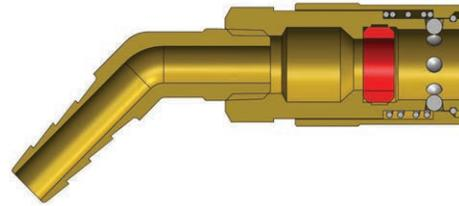
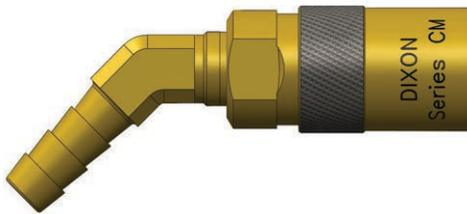

Body Size	CM-Series Industrial Mold Interchange Unvalved Coupler (45° Hose Barb)											
	Part Detail			List Price	Length		Maximum OD		Hex Inch	Weight Lb	Package Qty	
	Part Number	Hose ID	Material		Inch	mm	Inch	mm			Bag	Box
1/4"	2CM4S2-B-E	1/4"	brass	\$14.81	2.87	72.9	0.69	17.5	-	0.13	10	100
1/4"	2CM4S2.5-B-E	5/16"	brass	14.81	2.89	73.4	0.69	17.5	-	0.13	10	100
1/4"	2CM4S3-B-E	3/8"	brass	14.81	2.91	73.9	0.69	17.5	-	0.13	10	100
3/8"	3CM4S3-B-E	3/8"	brass	19.76	3.83	97.3	0.95	24.1	-	0.36	10	50
3/8"	3CM4S4-B-E	1/2"	brass	19.76	3.86	98.0	0.95	24.1	-	0.36	10	50
1/2"	4CM4S4-B-E	1/2"	brass	39.96	4.18	106.2	1.18	30.0	-	0.74	5	30
1/2"	4CM4S6-B-E	3/4"	brass	39.96	4.56	115.8	1.18	30.0	-	0.76	5	30

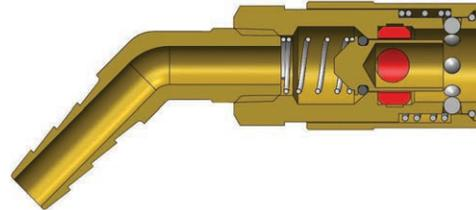
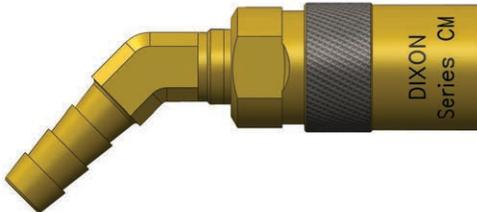

Body Size	CM-Series Industrial Mold Interchange Valved Coupler (45° Hose Barb)											
	Part Detail			List Price	Length		Maximum OD		Hex Inch	Weight Lb	Package Qty	
	Part Number	Hose ID	Material		Inch	mm	Inch	mm			Bag	Box
1/4"	2CM4S2-B	1/4"	brass	\$17.50	2.87	72.9	0.69	17.5	-	0.13	10	100
1/4"	2CM4S2.5-B	5/16"	brass	17.50	2.89	73.4	0.69	17.5	-	0.13	10	100
1/4"	2CM4S3-B	3/8"	brass	17.50	2.91	73.9	0.69	17.5	-	0.14	10	100
3/8"	3CM4S3-B	3/8"	brass	24.70	3.83	97.3	0.95	24.1	-	0.36	10	50
3/8"	3CM4S4-B	1/2"	brass	24.70	3.86	98.0	0.95	24.1	-	0.36	10	50

## CM-Series Hydraulic Couplings

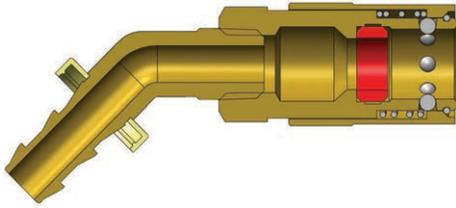

Body Size	CM-Series Industrial Mold Interchange Unvalved Coupler (45° Push-Loc Barb)											
	Part Detail			List Price	Length		Maximum OD		Hex Inch	Weight Lb	Package Qty	
	Part Number	Hose ID	Material		Inch	mm	Inch	mm			Bag	Box
1/4"	2CM4B2-B-E	1/4"	brass	<b>\$15.81</b>	2.86	72.6	0.69	17.5	-	0.13	10	100
1/4"	2CM4B3-B-E	3/8"	brass	<b>15.81</b>	2.92	74.2	0.69	17.5	-	0.15	10	100
3/8"	3CM4B3-B-E	3/8"	brass	<b>21.78</b>	3.82	97.0	0.95	24.1	-	0.34	10	50
3/8"	3CM4B4-B-E	1/2"	brass	<b>21.78</b>	3.98	101.1	0.95	24.1	-	0.34	10	50
1/2"	4CM4B4-B-E	1/2"	brass	<b>41.12</b>	4.28	108.7	1.18	30.0	-	0.83	5	30
1/2"	4CM4B6-B-E	3/4"	brass	<b>43.44</b>	4.56	115.8	1.18	30.0	-	0.83	5	30

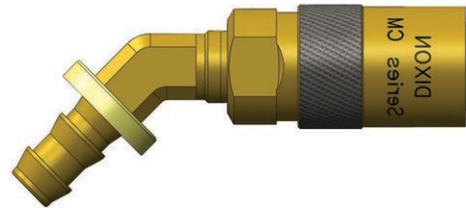
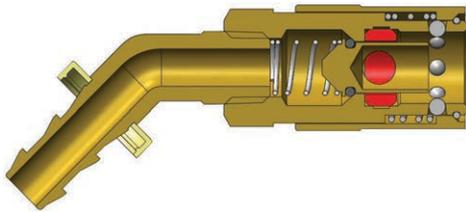

Body Size	CM-Series Industrial Mold Interchange Valved Coupler (45° Push-Loc Barb)											
	Part Detail			List Price	Length		Maximum OD		Hex Inch	Weight Lb	Package Qty	
	Part Number	Hose ID	Material		Inch	mm	Inch	mm			Bag	Box
1/4"	2CM4B2-B	1/4"	brass	<b>\$18.86</b>	2.86	72.6	0.69	17.5	-	0.14	10	100
1/4"	2CM4B3-B	3/8"	brass	<b>18.86</b>	2.92	74.2	0.69	17.5	-	0.17	10	100
3/8"	3CM4B3-B	3/8"	brass	<b>28.53</b>	3.82	97.0	0.95	24.1	-	0.36	10	50
3/8"	3CM4B4-B	1/2"	brass	<b>28.53</b>	3.98	101.1	0.95	24.1	-	0.40	10	50

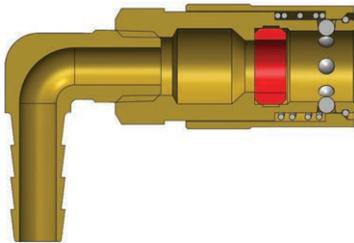

Body Size	CM-Series Industrial Mold Interchange Unvalved Coupler (90° Hose Barb)											
	Part Detail			List Price	Length		Maximum OD		Hex Inch	Weight Lb	Package Qty	
	Part Number	Hose ID	Material		Inch	mm	Inch	mm			Bag	Box
1/4"	2CM9S2-B-E	1/4"	brass	<b>\$14.81</b>	1.98	50.3	0.69	17.5	-	0.13	10	100
1/4"	2CM9S2.5-B-E	5/16"	brass	<b>14.81</b>	1.98	50.3	0.69	17.5	-	0.13	10	100
1/4"	2CM9S3-B-E	3/8"	brass	<b>14.81</b>	2.17	55.1	0.69	17.5	-	0.14	10	100
3/8"	3CM9S3-B-E	3/8"	brass	<b>19.76</b>	2.84	72.1	0.95	24.1	-	0.31	10	50
3/8"	3CM9S4-B-E	1/2"	brass	<b>19.76</b>	2.85	72.4	0.95	24.1	-	0.33	10	50
1/2"	4CM9S4-B-E	1/2"	brass	<b>46.93</b>	3.50	88.9	1.18	30.0	-	0.79	5	30
1/2"	4CM9S6-B-E	3/4"	brass	<b>47.54</b>	3.50	88.9	1.18	30.0	-	0.80	5	30

## CM-Series Hydraulic Couplings

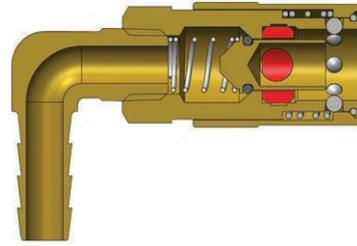

Body Size	CM-Series Industrial Mold Interchange Valved Coupler (90° Hose Barb)											
	Part Detail			List Price	Length		Maximum OD		Hex Inch	Weight Lb	Package Qty	
	Part Number	Hose ID	Material		Inch	mm	Inch	mm			Bag	Box
1/4"	2CM9S2-B	1/4"	brass	<b>\$19.76</b>	1.98	50.3	0.69	17.5	-	0.14	10	100
1/4"	2CM9S2.5-B	5/16"	brass	<b>19.76</b>	1.98	50.3	0.69	17.5	-	0.14	10	100
1/4"	2CM9S3-B	3/8"	brass	<b>19.76</b>	2.17	55.1	0.69	17.5	-	0.15	10	100
3/8"	3CM9S3-B	3/8"	brass	<b>24.94</b>	2.84	72.1	0.95	24.1	-	0.31	10	50
3/8"	3CM9S4-B	1/2"	brass	<b>24.94</b>	2.85	72.4	0.95	24.1	-	0.35	10	50

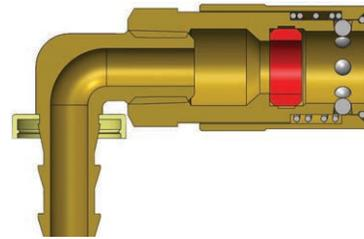
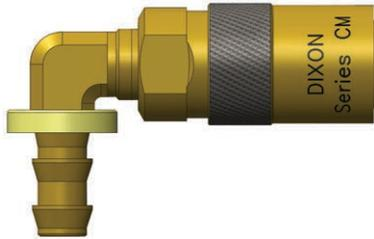

Body Size	CM-Series Industrial Mold Interchange Unvalved Coupler (90° Push-Loc Barb)											
	Part Detail			List Price	Length		Maximum OD		Hex Inch	Weight Lb	Package Qty	
	Part Number	Hose ID	Material		Inch	mm	Inch	mm			Bag	Box
1/4"	2CM9B2-B-E	1/4"	brass	<b>\$15.81</b>	2.07	52.6	0.69	17.5	-	0.14	10	100
1/4"	2CM9B3-B-E	3/8"	brass	<b>15.81</b>	2.17	55.1	0.69	17.5	-	0.16	10	100
3/8"	3CM9B3-B-E	3/8"	brass	<b>21.78</b>	2.93	74.4	0.95	24.1	-	0.37	10	50
3/8"	3CM9B4-B-E	1/2"	brass	<b>21.78</b>	2.98	75.7	0.95	24.1	-	0.37	10	50
1/2"	4CM9B4-B-E	1/2"	brass	<b>39.96</b>	3.50	88.9	1.18	30.0	-	0.83	5	30
1/2"	4CM9B6-B-E	3/4"	brass	<b>39.96</b>	3.50	88.9	1.18	30.0	-	0.83	5	30

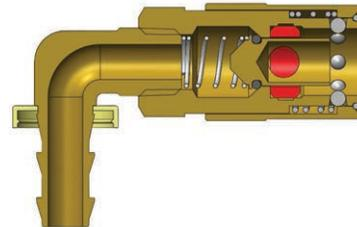
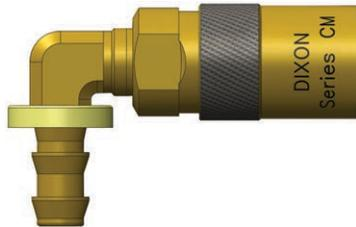

Body Size	CM-Series Industrial Mold Interchange Valved Coupler (90° Push-Loc Barb)											
	Part Detail			List Price	Length		Maximum OD		Hex Inch	Weight Lb	Package Qty	
	Part Number	Hose ID	Material		Inch	mm	Inch	mm			Bag	Box
1/4"	2CM9B2-B	1/4"	brass	<b>\$20.44</b>	2.07	52.6	0.69	17.5	-	0.14	10	100
1/4"	2CM9B3-B	3/8"	brass	<b>20.44</b>	2.17	55.1	0.69	17.5	-	0.17	10	100
3/8"	3CM9B3-B	3/8"	brass	<b>29.63</b>	2.93	74.4	0.95	24.1	-	0.37	10	50
3/8"	3CM9B4-B	1/2"	brass	<b>29.63</b>	2.98	75.7	0.95	24.1	-	0.39	10	50

## CM-Series Hydraulic Couplings

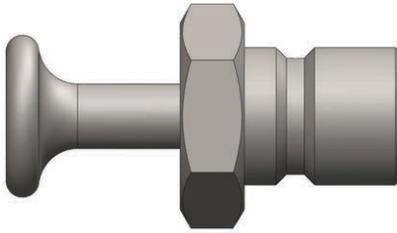

Body Size	CM-Series Coupler Rigid Dust Plug						
	Part Detail			List Price	Weight Lb	Package Qty	
	Part Number	Lanyard	Body			Bag	Box
1/4"	2CMPC-B	N/A	brass	<b>\$4.49</b>	0.09	10	100
3/8"	3CMPC-B	N/A	brass	<b>4.49</b>	0.12	10	50
1/2"	4CMPC-B	N/A	brass	<b>9.96</b>	0.15	5	30

Body Size	CM-Series Industrial Mold Interchange Coupler Seal Kits						
	Part Detail			List Price	Seal Kit Contents	Package Qty	
	Part Number	Coupler Style	Seal Material			Bag	Box
1/4"	2CM-SKIT	all	Silicone	<b>\$1.76</b>	Body Seal	25	200
3/8"	3CM-SKIT	all	Silicone	<b>2.01</b>	Body Seal	25	200
1/2"	4CM-SKIT	all	Silicone	<b>3.38</b>	Body Seal	25	200

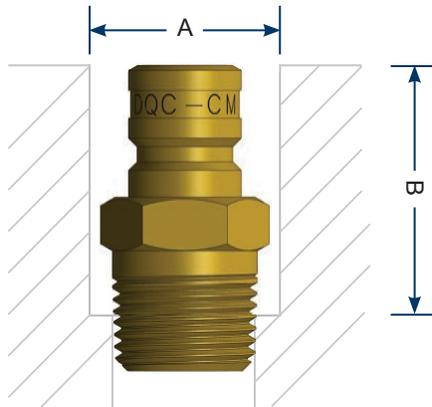

Counterbored mold ports will protect the male threaded nipple, allowing the nipple to be mounted below the surface, simplifying storing and handling of molds. Dixon male threaded plugs are constructed of corrosion resistant brass to maximize longevity in moist environments.

Body Size	Part Detail		Dimension A	Dimension B
	Part Number	Threads		
1/4"	CM2M1-B	1/8" - 27 NPTF	17.5 mm (0.69")	17.5 mm (0.69")
1/4"	CM2M2-B	1/4" - 18 NPTF	21.3 mm (0.84")	23.9 mm (0.94")
1/4"	CM2M3-B	3/8" - 18 NPTF	25.4 mm (1.00")	24.6 mm (0.97")
3/8"	CM3M2-B	1/4" - 18 NPTF	17.5 mm (0.69")	23.9 mm (0.94")
3/8"	CM3M3-B	3/8" - 18 NPTF	21.3 mm (0.84")	28.7 mm (1.13")
3/8"	CM3M4-B	1/2" - 14 NPTF	25.4 mm (1.00")	31.8 mm (1.25")
1/2"	CM4M4-B	1/2" - 14 NPTF	31.8 mm (1.25")	38.1 mm (1.50")
1/2"	CM4M6-B	3/4" - 14 NPTF	38.1 mm (1.50")	39.6 mm (1.56")

## Alpha Numeric Product Index

Part #	Page #	Part #	Page #	Part #	Page #	Part #	Page #
10BOP-SKIT	133	10VEPF10	122	12H-BRKIT	70	140032-16	99
10CVVBF10	138	10VEPF10-BOP	143	12H-RKIT	70	16BOP-SKIT	133
10CVVDP	140	10VEPOF10	122	12H-SKIT	69	16E-SKIT	153
10CVVF10	138	10VF10	88	12H-SRKIT	70	16EF16-B	149
10E-SKIT	153	10VF10-B	88	12H-SSRKIT	70	16EF16-S	149
10EF10-B	149	10VF10-SS	88	12HDP-A	68	16EM16-B	151
10EF10-S	149	10VOF10	88	12HTBF12	107	16K-SKIT	78
10EM10-B	151	12VF12	88	12HTF12	107	16ST-SKIT	118
10H-BRKIT	70	12VF12-B	88	12HTOF12	107	16STBF12	115
10H-RKIT	70	12VF12-SS	88	16HTF16	107	16STBF16	115
10H-SKIT	69	12VBF12	88	16HTBF16	107	16STDPA	117
10H-SRKIT	70	12VBF12-B	88	16HTOF16	107	16STF12	115
10H-SSRKIT	70	12VBF12-SS	88	12K-SKIT	78	16STF16	115
10HBF10	64	12VOF12	88	12V-SKIT	98	16STF16-SS	115
10HF10	64	16VF16	88	12VDP-A	97	16STOF12	115
10HF10-B	64	16VF16-B	88	12VEPBF12	122	16STOF16	115
10HF10-S	64	16VF16-SS	88	12VEPBF12-BOP	143	16V-SKIT	98
12HF10	64	16VBF16	88	12VEPDP-A	123	16VDP-A	97
12HF10-B	64	16VBF16-B	88	12VEPF12	122	16VEPBF16	122
12HF10-S	64	16VBF16-SS	88	12VEPF12-BOP	143	16VEPDP-A	123
12HOF10	64	10VF10-B-E	93	12VEPOF12	122	16VEPF16	122
12HF12	64	10VF10-E	93	12VF12-B-E	93	16VEPOF16	122
12HF12-B	64	10VF10-SS-E	93	12VF12-E	93	16VF16-B-E	93
12HF12-S	64	10VJM10	92	12VF12-SS-E	93	16VF16-E	93
12HF12-SS	64	10VM10	90	12VM12	90	16VF16-SS-E	93
12HBF12	64	10VM10-B	90	12VM12-B	90	16VM16	90
12HBF12-B	64	10VM10-E	95	12VM12-E	95	16VM16-B	90
12HBF12-S	64	10VM10-SS	90	12VM12-SS	90	16VM16-E	95
12HBF12-SS	64	10VM10-SS-E	95	12VM12-SS-E	95	16VM16-SS	90
12HOF12	64	10W-RKIT	128	12W-RKIT	128	16VM16-SS-E	95
20HF16	64	10WBF10-B	126	12WBF12-B	126	16WS-RKIT	133
20HF16-B	64	10WBF10-B-HN	126	12WBF12-B-HN	126	16WS-SKIT	133
20HF20	64	10WDP	128	12WDP	128	16WSBF16	130
20HF24	64	10WF10-B	126	12WF12-B	126	16WSBF16-BOP	145
10K-SKIT	78	10WF10-B-HN	126	12WF12-B-HN	126	16WSBF16-SS	130
10KBF10	76	10WS-RKIT	133	12WS-RKIT	133	16WSDPA	132
10KF10	76	10WS-SKIT	133	12WS-SKIT	133	16WSF16	130
12KF12	76	10WSBF10	130	12WSBF12	130	16WSF16-BOP	145
12KBF12	76	10WSBF10-BOP	145	12WSBF12-BOP	145	16WSF16-SS	130
16KF16	76	10WSBF10-SS	130	12WSBF12-SS	130	16WSF16-SS-BOP	145
16KBF16	76	10WSDPA	132	12WSDPA	132	16WSOF16	130
10V-SKIT	98	10WSF10	130	12WSF12	130	1AF1-B	55
10VBF10	88	10WSF10-BOP	145	12WSF12-BOP	145	2AF1-B	55
10VBF10-B	88	10WSF10-SS	130	12WSF12-SS	130	2AF2-B	55
10VBF10-B-E	93	10WSF10-SS-BOP	145	12WSF12-SS-BOP	145	1AM1-B	56
10VBF10-E	93	10WSOF10	130	12WSOF12	130	2AM1-B	56
10VBF10-SS	88	12BOP-SKIT	133	140030-10	99	2AM2-B	56
10VBF10-SS-E	93	12E-SKIT	153	140030-12	99	1AS1-B	56
10VDP-A	97	12EF12-B	149	140030-16	99	2AS2-B	56
10VEPBF10	122	12EF12-S	149	140032-10	99	1BRBF1-B-7	53
10VEPBF10-BOP	143	12EM12-B	151	140032-12	99	1BRBF2-B-7	53
10VEPDP-A	123						

## Alpha Numeric Product Index

Part #	Page #	Part #	Page #	Part #	Page #	Part #	Page #
1BRF1-B-7	53	2HF2-SS	62	2AGF2	80	3CM4S4-B	160
1BRF2-B-7	53	2HBF2	62	3AGF3	80	2CM4S2-B-E	160
1BRGM1-B-7	54	2HBF2-B	62	4AGF4	80	2CM4S2.5-B-E	160
1BRGM2-B-7	54	2HBF2-S	62	4AGBF4	80	2CM4S3-B-E	160
1BRM1-B-7	54	2HBF2-SS	62	4AGOF4	80	3CM4S3-B-E	160
1BRM2-B-7	54	2HOF3	62	4AGOF5	80	3CM4S4-B-E	160
1BRS1.25-B-7	54	3HF3	62	4AGF6	80	4CM4S4-B-E	160
1BRS1.86-B-7	54	3HF3-B	62	4AGBF6	80	4CM4S6-B-E	160
1BRS2.83-B-7	54	3HF3-S	62	6AGF6	80	2CM9B2-B	162
1EF1-B	149	3HF3-SS	62	8AGF8	80	2CM9B3-B	162
1EF1-S	149	3HBF3	62	2AGF2-PV	80	3CM9B3-B	162
2EF2-B	149	3HBF3-B	62	3AGF3-PV	80	3CM9B4-B	162
2EF2-S	149	3HBF3-S	62	4AGF4-PV	80	2CM9B2-B-E	162
2EBF2-B	149	3HBF3-SS	62	4AGBF4-PV	80	2CM9B3-B-E	162
3EF3-B	149	3HOF4	62	4AGOF4-PV	80	3CM9B3-B-E	162
3EF3-S	149	4HF4	62	4AGOF5-PV	80	3CM9B4-B-E	162
3EBF3-B	149	4HF4-B	62	4AGF6-PV	80	4CM9B4-B-E	162
4EF4-B	149	4HF4-S	62	4AGBF6-PV	80	4CM9B6-B-E	162
4EF4-S	149	4HF4-SS	62	6AGF6-PV	80	2CM9S2-B	162
4EBF4-B	149	4HBF4	62	8AGF8-PV	80	2CM9S2.5-B	162
6EF6-B	149	4HBF4-B	62	2CJBF2-B	31	2CM9S3-B	162
6EF6-S	149	4HBF4-S	62	2CJBF3-B	31	3CM9S3-B	162
6EBF6-B	149	4HBF4-SS	62	2CJBM2-B	32	3CM9S4-B	162
8EF8-B	149	4HOF5	62	2CJBM3-B	32	2CM9S2-B-E	161
8EF8-S	149	6HF6	62	2CJF2-B	31	2CM9S2.5-B-E	161
8EBF8-B	149	6HF6-B	62	2CJF3-B	31	2CM9S3-B-E	161
1EM1-B	151	6HF6-S	62	3CJF3-B	31	3CM9S3-B-E	161
1EM1-S	151	6HF6-SS	62	3CJBF3-B	31	3CM9S4-B-E	161
2EM2-B	151	6HBF6	62	3CJF4-B	31	4CM9S4-B-E	161
2EM2-S	151	6HBF6-B	62	3CJBF4-B	31	4CM9S6-B-E	161
3EM3-B	151	6HBF6-S	62	2CJM2-B	32	2CMB2-B	160
3EM3-S	151	6HBF6-SS	62	2CJM3-B	32	2CMB3-B	160
4EM4-B	151	6HOF6	62	3CJM3-B	32	3CMB3-B	160
4EM4-S	151	8HF8	62	3CJBM3-B	32	3CMB4-B	160
6EM6-B	151	8HF8-B	62	3CJM4-B	32	2CMB2-B-E	159
6EM6-S	151	8HF8-S	62	3CJBM4-B	32	2CMB3-B-E	159
8EM8-B	151	8HF8-SS	62	2CM-SKIT	163	3CMB3-B-E	159
8EM8-S	151	8HBF8	62	2CM4B2-B	161	3CMB4-B-E	159
1H-BSKIT	69	8HBF8-B	62	2CM4B3-B	161	4CMB4-B-E	159
1H-SKIT	69	8HBF8-S	62	3CM4B3-B	161	4CMB6-B-E	159
1HDP	67, 96	8HBF8-SS	62	3CM4B4-B	161	2CMF1-B	158
H1DC	120, 67	8HOF8	62	2CM4B2-B-E	161	3CMF2-B	158
V2DC	96	1PDF1	119	2CM4B3-B-E	161	2CMF1-B-E	158
1HF1	62	1PDF2	119	3CM4B3-B-E	161	2CMF2-B-E	158
1HF1-B	62	1PDM2	120	3CM4B4-B-E	161	3CMF2-B-E	158
1HF1-S	62	20HDP-A	68	4CM4B4-B-E	161	3CMF3-B-E	158
1HF1-SS	62	2AE2-B	57	4CM4B6-B-E	161	4CMF4-B-E	158
1HOF2	62	2AGDP	82	2CM4S2-B	160	2CMPC-B	163
2HF2	62	3AGDP	82	2CM4S2.5-B	160	3CMPC-B	163
2HF2-B	62	6AGDP	82	2CM4S3-B	160	4CMPC-B	163
2HF2-S	62	8AGDP	82	3CM4S3-B	160	2CMS2-B	159
						2CMS2.5-B	159

## Alpha Numeric Product Index

Part #	Page #	Part #	Page #	Part #	Page #	Part #	Page #
2CMS3-B	159	3DBF3-B	13	3FB3	20	3FS4	18
3CMS3-B	159	3DF4-B	13	3FB4	20	4FS3	18, 25
3CMS4-B	159	4DF3-B	13	4FB3	20, 26	4FS4	18, 25
2CMS2-B-E	159	4DF4-B	13	4FB4	20, 26	4FS4-S	18
2CMS2.5-B-E	159	4DF4-S	13	2FBF1-B	13	4FS6	18, 25
2CMS3-B-E	159	4DBF4-B	13	2FBF2-B	13	2H-BRKIT	70
3CMS3-B-E	159	4DF6-B	13	2FBF3-B	13	2H-BSKIT	69
3CMS4-B-E	159	6DF4-B	13	2FBM1-B	16	2H-RKIT	70
4CMS4-B-E	159	6DF6-B	13	2FBM2-B	16	2H-SKIT	69
4CMS6-B-E	159	6DF8-B	13	2FBM3-B	16	2H-SRKIT	70
2CVVBF2	138	2DM1-B	15	2FF1-B	13	2H-SSRKIT	70
2CVVDP	140	2DM2-B	15	2FF2	13	2HDP-A	68
3CVVDP	140	2DM2-S	15	2FF2-B	13	3HDP-A	68
4CVVDP	140	2DM3-B	15	2FF2-S	13	4HDP-A	68
6CVVDP	140	2DM3-S	15	2FF3-B	13	6HDP-A	68
8CVVDP	140	3DM2-B	15	2FF3-S	13	8HDP-A	68
2CVVF2	138	3DM3-B	15	3FF2	13	2HDP-H2DC	67
2CVVFM1415	138	3DM3-S	15	3FF3	13	2HSBF2-B	72
3CVVF3	138	3DBM3-B	15	3FF3-S	13	2HSBF2-S	72
3CVVBF3	138	3DM4-B	15	3FBF3	13	2HSF2-B	72
3CVVFM1615	138	4DM3-B	15	3FF4	13	2HSF2-S	72
4CVVF4	138	4DM4-B	15	4FF3	13, 23	3HSF3-B	72
4CVVOF4	138	4DM4-S	15	4FF4	13, 23	3HSF3-S	72
4CVVBF4	138	4DBM4-B	15	4FF4-S	13	3HSBF3-B	72
4CVVFM1815	138	4DM6-B	15	4FBF4	13	3HSBF3-S	72
4CVVOF5	138	6DM4-B	15	4FF6	13, 23	4HSF4-B	72
4CVVFM2215	138	6DM6-B	15	2FM1-B	16	4HSF4-S	72
6CVVF6	138	6DM8-B	15	2FM1-S	16	4HSBF4-B	72
6CVVBF6	138	2DS2-B	18	2FM2	16	4HSBF4-S	72
6CVVFM2215	138	2DS2-S	18	2FM2-B	16	6HSF6-B	72
8CVVF8	138	2DS3-B	18	2FM2-S	16	6HSF6-S	72
8CVVBF8	138	2DS3-S	18	2FM3-B	16	6HSBF6-B	72
2DB2-B	19	3DS2-B	18	2FM3-S	16	6HSBF6-S	72
2DB3-B	19	3DS3-B	18	3FM2	16	8HSF8-B	72
3DB3-B	19	3DS3-S	18	3FM3	16	8HSF8-S	72
4DB4-B	19	3DS4-B	18	3FM3-S	16	8HSBF8-B	72
2DBF2-B	13	4DS3-B	18	3FBM3	16	8HSBF8-S	72
2DBF3-B	13	4DS4-B	18	3FM4	16	2HT-BMK	109
2DBM2-B	15	4DS4-S	18	4FM3	16, 24	2HT-SKIT	109
2DBM3-B	15	4DS6-B	18	4FM4	16, 24	2HTBF2	104
2DE2-B	20	6DS4-B	18	4FM4-S	16	2HTDP	108
2DH2-B	20	6DS6-B	18	4FBM4	16	2HTF2	104
2DK3-B	20	6DS8-B	18	4FM6	16, 24	3HTF3	104
2DL3-B	20	2E-SKIT	153	2FS2	18	3HTF3-SS	104
2DF1-B	13	2ES2-B	152	2FS2-B	18	3HTBF3	104
2DF2-B	13	3ES3-B	152	2FS2-S	18	3HTBF3-SS	104
2DF2-S	13	4ES4-B	152	2FS2.5-B	18	3HTOF3	104
2DF3-B	13	6ES6-B	152	2FS3-B	18	3HTF4	104
2DF3-S	13	8ES8-B	152	2FS3-S	18	3HTF4-SS	104
3DF2-B	13	2FB2-B	20	3FS2	18	3HTBF4	104
3DF3-B	13	2FB3-B	20	3FS3	18	3HTBF4-SS	104
3DF3-S	13	3FB2	20	3FS3-S	18	3HTOF4	104



## Alpha Numeric Product Index

Part #	Page #	Part #	Page #	Part #	Page #	Part #	Page #
4HTF4	104	2JM3-B	24	4SHDF3	34	2T-SKIT	136
4HTF4-SS	104	3JM2	24	4SHDF4	34	2TDP	136
4HTBF4	104	3JM3	24	4SHDF6	34	3TDP	136
4HTBF4-SS	104	3JM4	24	2SHDM2	35	2TM2	135
4HTOF4	104	2JS2-B	25	2SHDM3	35	3TM3	135
4HTOF5	104	2JS3-B	25	4SHDM3	35	3TM3-SS	135
4HTF6	104	3JS2	25	4SHDM4	35	2UB2-B	40
4HTF6-SS	104	3JS3	25	2SHDS2	36	2UB3-B	40
4HTBF6	104	3JS4	25	2SHDS3	36	2UF2-B	40
4HTBF6-SS	104	2K-SKIT	78	4SHDS3	36	2UF3-B	40
4HTOF6	104	2KBF2	75	4SHDS4	36	3UF3-B	40
5HTOF5	104	2KDP-K2DC	78	2ST-BMK	118	2UM2-B	40
5HTF6	104	3KDP-K3DC	78, 96	2ST-SKIT	118	2UM3-B	40
5HTF6-SS	104	6KDP-K6DC	78	2STBF2	114	3UM3-B	40
5HTBF6	104	8KDP-K8DC	78	2STBF2-SS	114	2US2-B	40
5HTBF6-SS	104	2KF1	75	2STDP-A	117	2US3-B	40
5HTOF6	104	2KF2	75	3STDP-A	117	3US3-B	40
6HTOF5	104	2KOF2	75	4STDP-A	117	2V-BRKIT	99
6HTF6	104	3KF3	75	6STDP-A	117	2V-RKIT	99
6HTF6-SS	104	3KBF3	75	8STDP-A	117	2V-SKIT	98
6HTBF6	104	3KOF3	75	8STDP-A-V2	117	2V-SSRKIT	99
6HTBF6-SS	104	4KF4	75	2STF2	114	2VBF2	86
6HTOF6	104	4KBF4	75	2STF2-SS	114	2VBF2-B	86
6HTF8	104	4KOF4	75	3STF2	114	2VBF2-B-E	93
6HTF8-SS	104	4KOF5	75	3STF3	114	2VBF2-E	93
6HTBF8	104	4KF6	75	3STF3-SS	114	2VBF2-SS	86
6HTBF8-SS	104	4KBF6	75	3STBF3	114	2VBF2-SS-E	93
6HTOF8	104	2LF2-B	37	3STBF3-SS	114	2VDP-A	97
8HTF8	104	2LM2-B	38	3STF4	114	2VEPBF2	122
8HTF8-SS	104	2MF2-B	28	3STF4-SS	114	2VEPDP-A	123
8HTBF8	104	2MF3-B	28	3STBF4	114	2VEPF2	122
8HTBF8-SS	104	2MF2-PL	27	3STBF4-SS	114	2VEPOF3	122
8HTOF8	104	2MF3-PL	27	4STF4	114	2VF1	86
8HTF10	104	3MF3-PL	27	4STF4-SS	114	2VF2	86
8HTF10-SS	104	2MM2-B	29	4STBF4	114	2VF2-B	86
8HTBF10	104	2MM3-B	29	4STBF4-SS	114	2VF2-SS	86
8HTBF10-SS	104	2MM2-PL	28	4STOF4	114	2VOF2	86
8HTOF10	104	2MM3-PL	28	6STF6	114	3VF3	86
2HTOF3	104	3MM3-PL	28	6STF6-SS	114	3VF3-B	86
2JB2-B	26	2MS2-B	30	6STBF6	114	3VF3-SS	86
2JB3-B	26	2MS3-B	30	6STBF6-SS	114	3VBF3	86
3JB2	26	2MS2-PL	29	6STOF6	114	3VBF3-B	86
3JB3	26	2MS2.5-PL	29	8STF8	114	3VBF3-SS	86
3JB4	26	2MS3-PL	29	8STF8-SS	114	3VOF3	86
2JF1-B	23	3MS3-PL	29	8STBF8	114	3VF4	86
2JF2-B	23	2NKBF2	51	8STBF8-SS	114	4VF4	86
2JF3-B	23	2NKBM2	52	8STOF8	114	4VF4-B	86
3JF2	23	2NKF2	51	8STF10	114	4VF4-SS	86
3JF3	23	2NKM2	52	8STF10-SS	114	4VBF4	86
3JF4	23	2NKS2	52	8STBF10	114	4VBF4-B	86
2JM1-B	24	2SHDF2	34	8STBF10-SS	114	4VBF4-SS	86
2JM2-B	24	2SHDF3	34	8STOF10	114	4VOF4	86

## Alpha Numeric Product Index

Part #	Page #	Part #	Page #	Part #	Page #	Part #	Page #
4VF6	86	3VM3-B	90	4NS3	46	3VEPF4	122
6VF6	86	3VM3-SS	90	4NS3-B	46	3VEPOF4	122
6VF6-B	86	4VM4	90	4NS4	46	4AGF4-PS	81
6VF6-SS	86	4VM4-B	90	4NS4-B	46	4AGOF4-PS	81
6VBF6	86	4VM4-SS	90	4NS6	46	4AGOF5-PS	81
6VBF6-B	86	6VM6	90	4NS6-B	46	4AGF6-PS	81
6VBF6-SS	86	6VM6-B	90	4NS6-S	46	4AGF4-PV-PS	81
6VOF6	86	6VM6-SS	90	4NS8	46	4AGOF4-PV-PS	81
8VF8	86	8VM8	90	4NS8-B	46	4AGOF5-PV-PS	81
8VF8-B	86	8VM8-B	90	4NS8-S	46	4AGF6-PV-PS	81
8VF8-SS	86	8VM8-SS	90	3NM4	44	4CM-SKIT	163
8VBF8	86	2VM2-B-E	95	4NM3	44	4E-SKIT	153
8VBF8-B	86	2VM2-E	95	4NM3-B	44	4EA-SKIT	155
8VBF8-SS	86	2VM2-SS-E	95	4NBM3	44	4EAF3	155
8VOF8	86	3VM3-E	95	4NM4	44	4EAF4	155
2VF2-B-E	93	3VM3-B-E	95	4NM4-B	44	4H-BRKIT	70
2VF2-E	93	3VM3-SS-E	95	4NBM4	44	4H-BSKIT	69
2VF2-SS-E	93	4VM4-E	95	4NBM4-B	44	4H-RKIT	70
3VF3-E	93	4VM4-B-E	95	4NM6	44	4H-SKIT	69
3VF3-B-E	93	4VM4-SS-E	95	4NM6-B	44	4H-SRKIT	70
3VF3-SS-E	93	6VM6-E	95	4NM6-S	44	4H-SSRKIT	70
3VBF3-E	93	6VM6-B-E	95	4NBM6	44	4HDP-H4DC	67
3VBF3-B-E	93	6VM6-SS-E	95	4NBM6-B	44	4HF4-BOP	147
3VBF3-SS-E	93	8VM8-E	95	4NM8	44	4HF4-HV	66
4VF4-E	93	8VM8-B-E	95	4NM8-B	44	4HF4-SS-BOP	147
4VF4-B-E	93	8VM8-SS-E	95	4NBM8	44	4HT-BMK	109
4VF4-SS-E	93	3CM-SKIT	163	4NBM8-B	44	4HT-SKIT	109
4VBF4-E	93	3E-SKIT	153	3ST-BMK	118	4HTJB5	107
4VBF4-B-E	93	3H-BRKIT	70	3ST-SKIT	118	4HTRB5	107
4VBF4-SS-E	93	3H-BSKIT	69	3T-SKIT	136	4HTJB6	107
6VF6-E	93	3H-RKIT	70	3TF3	135	4K-B-DP	78
6VF6-B-E	93	3H-SKIT	69	3TM3-PV	135	4K-G-DP	78
6VF6-SS-E	93	3H-SRKIT	70	3TM3-SS-PV	135	4K-O-DP	78
6VBF6-E	93	3H-SSRKIT	70	3TR-SKIT	101	4K-R-DP	78
6VBF6-B-E	93	3HDP-H3DC	67	3TRBF3	101	4K-SKIT	78
6VBF6-SS-E	93	3HT-BMK	109	3TRF3	101	4K-Y-DP	78
8VF8-E	93	3HT-SKIT	109	4TRF4	101	4KDP	78
8VF8-B-E	93	3HTDP	108	4TRBF4	101	4N-SKIT	47
8VF8-SS-E	93	4HTDP	108	6TRF6	101	4N4N	47
8VBF8-E	93	5HTDP	108	6TRBF6	101	4NBF3	42
8VBF8-B-E	93	6HTDP	108	8TRF8	101	4NBF4	42
8VBF8-SS-E	93	8HTDP	108	8TRBF8	101	4NBF4-B	42
2VJM2	92	3HTM3	106	3V-BRKIT	99	4NBF6	42
3VJM3	92	3HTM4	106	3V-RKIT	99	4NBF6-B	42
4VJM4	92	4HTM4	106	3V-SKIT	98	4NBF8	42
6VJM6	92	3HTOM3	106	3V-SSRKIT	99	4NBF8-B	42
8VJM8	92	3HTOM4	106	3VDP-A	97	4NF3	42
2VM1	90	3K-SKIT	78	3VDP-V3DC	96	4NF3-B	42
2VM2	90	3MM4-PL	28	3VEPBF3	122	4NF4	42
2VM2-B	90	3N-SKIT	47	3VEPBF4	122	4NF4-B	42
2VM2-SS	90	3NBM4	44	3VEPDP-A	123	4NF6	42
3VM3	90	3NCS4	46	3VEPF3	122	4NF6-B	42

## Alpha Numeric Product Index

Part #	Page #	Part #	Page #	Part #	Page #	Part #	Page #
4NF6-S	42	6HF6-BOP	147	6WSOF6	130	A2M2	56
4NF8	42	6HF6-SS_BOP	147	8WSF8	130	A2M2-B	56
4NF8-B	42	6HT-BMK	109	8WSF8-SS	130	A1S1-B	57
4P-SKIT	50	6HT-SKIT	109	8WSBF8	130	A2S2	57
4PF4	49	6K-SKIT	78	8WSBF8-SS	130	A2E2	57
4PF6	49	6KBF6	76	8WSOF8	130	A2E2-B	57
4PF6-B	49	6KF6	76	6WSF4-BOP	145	AG2DC	82
4PF6-S	49	6KOF6	76	6WSF6-BOP	145	AG3DC	82
4PM3	49	8KF8	76	6WSF6-SS-BOP	145	AG6DC	82
4PM4	49	8KBF8	76	8BOP-SKIT	133	AG8DC	82
4PM6	49	8KOF8	76	8E-SKIT	153	AG2F2	81
4PM6-9	49	6ST-BMK	118	8H-BRKIT	70	AG3F3	81
4PM6-S	49	6ST-SKIT	118	8H-BSKIT	69	AG4F4	81
4PM8	49	6TR-SKIT	101	8H-RKIT	70	AG4BF4	81
4PS3	50	6V-BRKIT	99	8H-SKIT	69	AG4OF4	81
4PS4	50	6V-RKIT	99	8H-SRKIT	70	AG4OF5	81
4PS4-B	50	6V-SKIT	98	8H-SSRKIT	70	AG4F6	81
4PS6	50	6V-SSRKIT	99	8HDP-H8DC	67	AG4BF6	81
4PS6-9	50	6VDP-A	97	8HF8-BOP	147	AG6F6	81
4PS6-B	50	6VDP-V6DC	96	8HF8-SS-BOP	147	AG8F8	81
4PS6-S	50	6VEPBF6	122	8HT-BMK	109	AG2F2-PV	82
4PS8	50	6VEPBF6-BOP	143	8HT-SKIT	109	AG3F3-PV	82
4PS8-B	50	6VEPDP-A	123	8K-SKIT	78	AG4F4-PV	82
4ST-BMK	118	6VEPF6	122	8ST-SKIT	118	AG4BF4-PV	82
4ST-SKIT	118	6VEPF6-BOP	143	8ST-SKIT-V2	118	AG4OF4-PV	82
4TR-SKIT	101	6VEPOF6	122	8STBF8-V2	115	AG4OF5-PV	82
4V-BRKIT	99	6W-RKIT	128	8STF10-V2	115	AG4F6-PV	82
4V-RKIT	99	6WBF4-B	126	8STF8-V2	115	AG4BF6-PV	82
4V-SKIT	98	6WBF4-B-HN	126	8TR-SKIT	101	AG6F6-PV	82
4V-SSRKIT	99	6WBF6-B	126	8V-BRKIT	99	AG8F8-PV	82
4VDP-A	97	6WBF6-B-HN	126	8V-RKIT	99	BR1BF1-B-E-7	53
4VEP4-BOP	143	6WDP	128	8V-SKIT	98	BR1BF2-B-E-7	53
4VEPBF4	122	8WDP	128	8V-SSRKIT	99	BR1F1-B-E-7	53
4VEPBF4-BOP	143	6WF4-B	126	8VDP-A	97	BR1F2-B-E-7	53
4VEPBF6	122	6WF6-B	126	8VDP-V8DC	96	BR1GM1-B-E-7	54
4VEPDP-A	123	8WF8-B	126	8VEPBF8	122	BR1GM2-B-E-7	54
4VEPF4	122	8WF8	126	8VEPBF8-BOP	143	BR1M1-B-E-7	54
4VEPF6	122	8WBF8-B	126	8VEPDP-A	123	BR1M2-B-E-7	54
4VEPOF4	122	6WF4-B-HN	126	8VEPF8	122	BR1S1.25-B-E-7	54
4VEPOF5	122	6WF6-B-HN	126	8VEPF8-BOP	143	BR1S1.86-B-E-7	54
4VEPOF6	122	8WF8-B-HN	126	8VEPOF8	122	BR1S2.83-B-E-7	54
5HT-BMK	109	8WBF8-B-HN	126	8W-RKIT	128	CJ2BF2-B	32
5HT-SKIT	109	6WS-RKIT	133	8WS-RKIT	133	CJ2BF2-LG	32
6BOP-SKIT	133	6WS-SKIT	133	8WS-SKIT	133	CJ2BF3-B	32
6E-SKIT	153	6WSBF6	130	8WSBF8-BOP	145	CJ2BF3-LG	32
6H-BRKIT	70	6WSBF6-BOP	145	8WSF8-BOP	145	CJ2BM2-B	33
6H-BSKIT	69	6WSBF6-SS	130	8WSF8-SS-BOP	145	CJ2BM2-LG	33
6H-RKIT	70	6WSDP-A	132	A1F1-B	56	CJ2BM3-B	33
6H-SKIT	69	8WSDP-A	132	A2F1-B	56	CJ2BM3-LG	33
6H-SRKIT	70	6WSF4	130	A2F2	56	CJ2F2-B	32
6H-SSRKIT	70	6WSF6	130	A2F2-B	56	CJ2F2-LG	32
6HDP-H6DC	67	6WSF6-SS	130	A1M1-B	56	CJ2F3-LG	32

## Alpha Numeric Product Index

Part #	Page #	Part #	Page #	Part #	Page #	Part #	Page #
CJ2F3-B	32	CM3M2-B-L2.5	158	D2K3	20	D2S2-B	19
CJ3F3	32	CM3M2-B-L4	158	D2L3	20	D2S2-S	19
CJ3F3-B	32	CM3M2-B-L5.5	158	D2F1	14	D2S2.5	19
CJ3BF3	32	CM3M2-B-L7	158	D2F2	14	D2S3	19
CJ3BF3-B	32	CM3M2-B-L8.5	158	D2F2-B	14	D2S3-B	19
CJ3F4	32	CM3M2-B-L11.5	158	D2F2-S	14	D2S3-S	19
CJ3F4-B	32	CVV10BF10	139	D2F3	14	D3S2	19
CJ3BF4	32	CVV10DC	140	D2F3-B	14	D3S3	19
CJ3BF4-B	32	CVV10F10	139	D2F3-S	14	D3S3-B	19
CJ2M2-B	33	CVV2BF2	139	D3F2	14	D3S3-S	19
CJ2M2-LG	33	CVV2DC	140	D3F3	14	D3S4	19
CJ2M3-LG	33	CVV3DC	140	D3F3-B	14	D4S3	19
CJ2M3-B	33	CVV4DC	140	D3F3-S	14	D4S3-B	19
CJ3M3	33	CVV6DC	140	D3BF3	14	D4S4	19
CJ3M3-B	33	CVV8DC	140	D3F4	14	D4S4-B	19
CJ3BM3	33	CVV2F2	139	D4F3	14	D4S4-S	19
CJ3BM3-B	33	CVV2FM1415	139	D4F4	14	D4S6	19
CJ3M4	33	CVV3F3	139	D4F4-B	14	D4S6-B	19
CJ3M4-B	33	CVV3BF3	139	D4F4-S	14	D6S4	19
CJ3BM4	33	CVV3FM1615	139	D4BF4	14	D6S6	19
CJ3BM4-B	33	CVV4F4	139	D4F6	14	D6S8	19
CM2F1	157	CVV4OF4	139	D4F6-B	14	E10F10	150
CM2F1-B	157	CVV4BF4	139	D6F4	14	E10F10-B	150
CM2F2	157	CVV4FM1815	139	D6F6	14	E10F10-S	150
CM2F2-B	157	CVV4OF5	139	D6F8	14	E10M10	152
CM2F3	157	CVV4FM2215	139	D2M1	17	E10M10-B	152
CM2F3-B	157	CVV6F6	139	D2M1-B	17	E12F12	150
CM3F2	157	CVV6BF6	139	D2M1-S	17	E12F12-B	150
CM3F2-B	157	CVV6FM2215	139	D2M2	17	E12F12-S	150
CM3F3	157	CVV8F8	139	D2M2-B	17	E12M12	152
CM3F3-B	157	CVV8BF8	139	D2M2-S	17	E12M12-B	152
CM4F4-B	157	D-4HF4-S-FNS	66	D2M3	17	E16F16	150
CM4F6-B	157	D-4HF4-SS-FNS	66	D2M3-B	17	E16F16-B	150
CM2M1-B	157, 163	D-4HF4-S-FSB	66	D2M3-S	17	E16F16-S	150
CM2M2-B	157, 163	D-4HF4-SS-FSB	66	D3M2	17	E16M16	152
CM2M3-B	157, 163	D-H4F4-S	67	D3M3	17	E16M16-B	152
CM3M2-B	157, 163	D-H4F4-SS	67	D3M3-B	17	E1F1	150
CM3M3-B	157, 163	D-H4F4-SV-8	67	D3M3-S	17	E1F1-B	150
CM3M4-B	157, 163	D2B2	20	D3BM3	17	E1F1-S	150
CM4M4-B	157, 163	D2B2-B	20	D3M4	17	E2F2	150
CM4M6-B	157, 163	D2B3	20	D4M2	17	E2F2-B	150
CM2M1-B-L2.5	158	D3B2	20	D4M3	17	E2F2-S	150
CM2M1-B-L4	158	D3B3	20	D4M4	17	E2BF2-B	150
CM2M1-B-L5.5	158	D3B4	20	D4M4-B	17	E3F3	150
CM2M2-B-L2.5	158	D4B4	20	D4M4-S	17	E3F3-B	150
CM2M2-B-L4	158	D6B6	20	D4BM4	17	E3F3-S	150
CM2M2-B-L5.5	158	D2BF2	14	D4M6	17	E3BF3-B	150
CM2M2-B-L7	158	D2BF3	14	D4M6-B	17	E4F4	150
CM3M1-B-L2.5	158	D2BM2	17	D6M4	17	E4F4-B	150
CM3M1-B-L4	158	D2BM3	17	D6M6	17	E4F4-S	150
CM3M1-B-L5.5	158	D2E2	20	D6M8	17	E4BF4-B	150
CM3M1-B-L7	158	D2H2	20	D2S2	19	E6F6	150

## Alpha Numeric Product Index

Part #	Page #	Part #	Page #	Part #	Page #	Part #	Page #
E6F6-B	150	F-3H-BSKIT	69	H2BF2-SS	63	H8F8-SS-BOP	147
E6F6-S	150	F-3H-SKIT	69	H2OF3	63	HS2BF2	73
E6BF6-B	150	F-3V-SKIT	98	H3F3	63	HS2BF2-B	73
E8F8	150	F-4E-SKIT	153	H3F3-B	63	HS2BF2-S	73
E8F8-B	150	F-4EA-SKIT	155	H3F3-S	63	HS2F2	73
E8F8-S	150	F-4H-BSKIT	69	H3F3-SS	63	HS2F2-B	73
E8BF8-B	150	F-4H-SKIT	69	H3BF3	63	HS2F2-S	73
E1M1	152	F-4N-SKIT	47	H3BF3-B	63	HS3F3	73
E1M1-B	152	F-4P-SKIT	50	H3BF3-S	63	HS3F3-B	73
E1M1-S	152	F-4V-SKIT	98	H3BF3-SS	63	HS3F3-S	73
E2M2	152	F-6E-SKIT	153	H3OF4	63	HS3BF3	73
E2M2-B	152	F-6H-BSKIT	69	H4F4	63	HS3BF3-B	73
E2M2-S	152	F-6H-SKIT	69	H4F4-B	63	HS3BF3-S	73
E3M3	152	F-6V-SKIT	98	H4F4-S	63	HS4F4	73
E3M3-B	152	F-8E-SKIT	153	H4F4-SS	63	HS4F4-B	73
E3M3-S	152	F-8H-BSKIT	69	H4BF4	63	HS4F4-S	73
E4M4	152	F-8H-SKIT	69	H4BF4-B	63	HS4BF4	73
E4M4-B	152	F-8V-SKIT	98	H4BF4-S	63	HS4BF4-B	73
E4M4-S	152	H10BF10	65	H4BF4-SS	63	HS4BF4-S	73
E6M6	152	H10F10	65	H4OF5	63	HS6F6	73
E6M6-B	152	H10F10-B	65	H6F6	63	HS6F6-B	73
E6M6-S	152	H10F10-S	65	H6F6-B	63	HS6F6-S	73
E8M8	152	H12F10	65	H6F6-S	63	HS6BF6	73
E8M8-B	152	H12F10-B	65	H6F6-SS	63	HS6BF6-B	73
E8M8-S	152	H12F10-S	65	H6BF6	63	HS6BF6-S	73
E2S2	153	H12OF10	65	H6BF6-B	63	HS8F8	73
E2S2-B	153	H12F12	65	H6BF6-S	63	HS8F8-B	73
E3S3	153	H12F12-B	65	H6BF6-SS	63	HS8F8-S	73
E3S3-B	153	H12F12-S	65	H6OF6	63	HS8BF8	73
E4S4	153	H12F12-SS	65	H8F8	63	HS8BF8-B	73
E4S4-B	153	H12BF12	65	H8F8-B	63	HS8BF8-S	73
E6S6	153	H12BF12-B	65	H8F8-S	63	HT12BF12	107
E6S6-B	153	H12BF12-S	65	H8F8-SS	63	HT12F12	107
E8S8	153	H12BF12-SS	65	H8BF8	63	HT12OF12	107
E8S8-B	153	H12OF12	65	H8BF8-B	63	HT16BF16	107
EA4F3	155	H20F16	65	H8BF8-S	63	HT16F16	107
EA4F4	155	H20F16-B	65	H8BF8-SS	63	HT16OF16	107
F-10-SKIT	69	H20F20	65	H8OF8	63	HT2-SKIT-V2	109
F-10E-SKIT	153	H20F24	65	H20DC-A	68	HT2BF2	105
F-10V-SKIT	98	H12DC-A	68	H2DC-A	68	HT2DC	108
F-12E-SKIT	153	H1F1	63	H3DC-A	68	HT2F2	105
F-12H-SKIT	69	H1F1-B	63	H4DC-A	68	HT2OF3	105
F-12V-SKIT	98	H1F1-S	63	H6DC-A	68	HT3F3	105
F-16E-SKIT	153	H1F1-SS	63	H8DC-A	68	HT3F3-SS	105
F-16V-SKIT	98	H1OF2	63	H2M3	65	HT3BF3	105
F-1H-BSKIT	69	H2F2	63	H4M6-S	65	HT3BF3-SS	105
F-1H-SKIT	69	H2F2-B	63	H4F4-BOP	147	HT3OF3	105
F-2E-SKIT	153	H2F2-S	63	H4F4-HV	66	HT3F4	105
F-2H-BSKIT	69	H2F2-SS	63	H4F4-SS-BOP	147	HT3F4-SS	105
F-2H-SKIT	69	H2BF2	63	H6F6-BOP	147	HT3BF4	105
F-2V-SKIT	98	H2BF2-B	63	H6F6-SS_BOP	147	HT3BF4-SS	105
F-3E-SKIT	153	H2BF2-S	63	H8F8-BOP	147	HT3OF4	105

## Alpha Numeric Product Index

Part #	Page #	Part #	Page #	Part #	Page #	Part #	Page #
HT4F4	105	HT4JB6	107	J4M4	24	M3M3	29
HT4F4-SS	105	HT5-SKIT-V2	109	J4M6	24	M2S2	30
HT4BF4	105	HT6-SKIT-V2	109	J2S2	25	M2S3	30
HT4BF4-SS	105	HT8-SKIT-V2	109	J2S3	25	M3S3	30
HT4OF4	105	HTE3BF4	112	J3S2	25	N3BM4	45
HT4OF5	105	HTE3F4	112	J3S3	25	N3CS4	46
HT4F6	105	HTE3OF4	112	J3S4	25	N4S3	46
HT4F6-SS	105	HTE4BF4	112	J4S3	25	N4S3-B	46
HT4BF6	105	HTE4BF6	112	J4S4	25	N4S4	46
HT4BF6-SS	105	HTE4F4	112	J4S6	25	N4S4-B	46
HT4OF6	105	HTE4F6	112	K10BF10	77	N4S6	46
HT5OF5	105	HTE4OF4	112	K10F10	77	N4S6-B	46
HT5F6	105	HTE4OF5	112	K12BF12	77	N4S6-S	46
HT5F6-SS	105	HTE4OF6	112	K12F12	77	N4S8	46
HT5BF6	105	HTE5BF6	112	K16BF16	77	N4S8-B	46
HT5BF6-SS	105	HTE5F6	112	K16F16	77	N4S8-S	46
HT5OF6	105	HTE5OF5	112	K2BF2	77	N3M4	45
HT6OF5	105	HTE5OF6	112	K2F1	77	N4M3	45
HT6F6	105	HTE6BF6	112	K2F2	77	N4M3-B	45
HT6F6-SS	105	HTE6BF8	112	K2OF2	77	N4BM3	45
HT6BF6	105	HTE6F6	112	K3F3	77	N4M4	45
HT6BF6-SS	105	HTE6F8	112	K3BF3	77	N4M4-B	45
HT6OF6	105	HTE6OF6	112	K3OF3	77	N4BM4	45
HT6F8	105	HTE6OF8	112	K4F4	77	N4BM4-B	45
HT6F8-SS	105	HTE8BF10	112	K4BF4	77	N4M6	45
HT6BF8	105	HTE8BF8	112	K4OF4	77	N4M6-B	45
HT6BF8-SS	105	HTE8F10	112	K4OF5	77	N4M6-S	45
HT6OF8	105	HTE8F8	112	K4F6	77	N4BM6	45
HT8F8	105	HTE8OF10	112	K4BF6	77	N4BM6-B	45
HT8F8-SS	105	HTE8OF8	112	K4-B-DC	78	N4M8	45
HT8BF8	105	J2B2	26	K4-G-DC	78	N4M8-B	45
HT8BF8-SS	105	J2B3	26	K4-O-DC	78	N4BM8	45
HT8OF8	105	J3B3	26	K4-R-DC	78	N4BM8-B	45
HT8F10	105	J4B4	26	K4-Y-DC	78	N4BF3	43
HT8F10-SS	105	J2F1	23	K4DC	78	N4BF4	43
HT8BF10	105	J2F2	23	K6BF6	77	N4BF4-B	43
HT8BF10-SS	105	J2F2-B	23	K6F6	77	N4BF6	43
HT8OF10	105	J2F3	23	K6OF6	77	N4BF6-B	43
HT3-SKIT-V2	109	J3F2	23	K8F8	77	N4BF8	43
HT3DC	108	J3F3	23	K8BF8	77	N4BF8-B	43
HT4DC	108	J3F4	23	K8OF8	77	N4BM4-LS	45
HT5DC	108	J4F3	23	L2F2	37	N4BM6-LS	45
HT6DC	108	J4F4	23	L2M2	38	N4DC	47
HT8DC	108	J4F6	23	M2B2	30	N4DC-B	47
HT3M3	106	J2M1	24	M2F2	28	N4F3	43
HT3M4	106	J2M2	24	M2F2-B	28	N4F3-B	43
HT4M4	106	J2M2-B	24	M2F3	28	N4F4	43
HT3OM3	106	J2M3	24	M3F3	28	N4F4-B	43
HT3OM4	106	J3M2	24	M2M1	29	N4F6	43
HT4-SKIT-V2	109	J3M3	24	M2M2	29	N4F6-B	43
HT4JB5	107	J3M4	24	M2M2-B	29	N4F6-S	43
HT4RB5	107	J4M3	24	M2M3	29	N4F8	43

## Alpha Numeric Product Index

Part #	Page #	Part #	Page #	Part #	Page #	Part #	Page #
N4F8-B	43	P4F6	49	SCVS24	59	ST8F8-SS	116
N4F4-B-LS	43	P4F6-9	49	SHD2F1	35	ST8BF8	116
N4F6-B-LS	43	P4F6-B	49	SHD2F2	35	ST8BF8-SS	116
N4M4-B-LS	45	P4F6-S	49	SHD4F3	35	ST8OF8	116
N4M4-LS	45	P4F8	49	SHD2M1	35	ST8F10	116
N4M6-LS	45	P4F8-B	49	SHD2M2	35	ST8F10-SS	116
N4M6-B-LS	45	P4M3	50	SHD4M3	35	ST8BF10	116
N4M6-S-LS	45	P4M4	50	SHD4M4	35	ST8BF10-SS	116
N4S4-B-LS	47	P4M4-B	50	SHD2S2	36	ST8OF10	116
N4S4-LS	47	P4M6	50	SHD2S3	36	ST3-SKIT	118
N4S6-LS	47	P4M6-9	50	SHD4S3	36	ST4-SKIT	118
N4S6-B-LS	47	P4M6-B	50	SHD4S4	36	ST6-SKIT	118
N4S6-S-LS	47	P4M6-S	50	ST16-SKIT	118	ST8-SKIT	118
NK2BF2	51	P4M8	50	ST16BF12	117	ST8BF8-V2	117
NK2BM2	52	P4M8-B	50	ST16BF16	117	ST8F10-V2	117
NK2F2	51	PD1F1	119	ST16DC-A	117	ST8F8-V2	117
NK2M2	52	PD1F2	119	ST16F12	117	T2DC	136
NK2S2	52	PD1M1	120	ST16F16	117	T3DC	136
P-10-SKIT	69	PD1M2	120	ST16F16-SS	117	T2F2	135
P-10E-SKIT	153	PD1OM2	120	ST16OF12	117	T3F3	135
P-10V-SKIT	98	PD1OM3	120	ST16OF16	117	T3F3-SS	135
P-12E-SKIT	153	SCVH10	59	ST2-SKIT	118	T3F3-PV	136
P-12H-SKIT	69	SCVH12	59	ST2BF2	116	T3F3-SS-PV	136
P-12V-SKIT	98	SCVH16	59	ST2BF2-SS	116	TR3BF3	101
P-16E-SKIT	153	SCVH24	59	ST2DC-A	117	TR3F3	101
P-16V-SKIT	98	SCVH6	59	ST3DC-A	117	TR4F4	101
P-1H-BSKIT	69	SCVH8	59	ST4DC-A	117	TR4BF4	101
P-1H-SKIT	69	SCVJ6	59	ST6DC-A	117	TR6F6	101
P-2E-SKIT	153	SCVL10	59	ST8DC-A	117	TR6BF6	101
P-2H-BSKIT	69	SCVL12	59	ST8DC-A-V2	117	TR8F8	101
P-2H-SKIT	69	SCVL16	59	ST2F2	116	TR8BF8	101
P-2V-SKIT	98	SCVL2	59	ST2F2-SS	116	V10BF10	89
P-3E-SKIT	153	SCVL3	59	ST3F2	116	V10BF10-B	89
P-3H-BSKIT	69	SCVM3	59	ST3F3	116	V10BF10-B-E	94
P-3H-SKIT	69	SCVS3	59	ST3F3-SS	116	V10BF10-E	94
P-3V-SKIT	98	SCVM4	59	ST3BF3	116	V10BF10-SS	89
P-4E-SKIT	153	SCVS4	59	ST3BF3-SS	116	V10BF10-SS-E	94
P-4EA-SKIT	155	SCVL6	59	ST3F4	116	V10DC-A	97
P-4H-BSKIT	69	SCVM6	59	ST3F4-SS	116	V10F10	89
P-4H-SKIT	69	SCVR6	59	ST3BF4	116	V10F10-B	89
P-4V-SKIT	98	SCVS6	59	ST3BF4-SS	116	V10F10-SS	89
P-6E-SKIT	153	SCVL8	59	ST4F4	116	V10OF10	89
P-6H-BSKIT	69	SCVM8	59	ST4F4-SS	116	V12F12	89
P-6H-SKIT	69	SCVS8	59	ST4BF4	116	V12F12-B	89
P-6V-SKIT	98	SCVM10	59	ST4BF4-SS	116	V12F12-SS	89
P-8E-SKIT	153	SCVS10	59	ST4OF4	116	V12BF12	89
P-8H-BSKIT	69	SCVM12	59	ST6F6	116	V12BF12-B	89
P-8H-SKIT	69	SCVX12	59	ST6F6-SS	116	V12BF12-SS	89
P-8V-SKIT	98	SCVS12	59	ST6BF6	116	V12OF12	89
P4F3	49	SCVM16	59	ST6BF6-SS	116	V16F16	89
P4F4	49	SCVS16	59	ST6OF6	116	V16F16-B	89
P4F4-B	49	SCVL24	59	ST8F8	116	V16F16-SS	89

## Alpha Numeric Product Index

Part #	Page #	Part #	Page #	Part #	Page #	Part #	Page #
V16BF16	89	V3F4	87	V4JM4	92	VEP10DC-A	123
V16BF16-B	89	V4F4	87	V6JM6	92	VEP10F10	123
V16BF16-SS	89	V4F4-B	87	V8JM8	92	VEP10F10-BOP	143
V10F10-B-E	94	V4F4-SS	87	V2M1	91	VEP10OF10	123
V10F10-E	94	V4BF4	87	V2M2	91	VEP12BF12	123
V10F10-SS-E	94	V4BF4-B	87	V2M2-B	91	VEP12BF12-BOP	143
V10JM10	92	V4BF4-SS	87	V2M2-SS	91	VEP12DC-A	123
V10M10	91	V4OF4	87	V3M3	91	VEP12F12	123
V10M10-B	91	V4F6	87	V3M3-B	91	VEP12F12-BOP	143
V10M10-E	96	V6F6	87	V3M3-SS	91	VEP12OF12	123
V10M10-SS	91	V6F6-B	87	V4M4	91	VEP16BF16	123
V10M10-SS-E	96	V6F6-SS	87	V4M4-B	91	VEP16DC-A	123
V12DC-A	97	V6BF6	87	V4M4-SS	91	VEP16F16	123
V12F12-B-E	94	V6BF6-B	87	V6M6	91	VEP16OF16	123
V12F12-E	94	V6BF6-SS	87	V6M6-B	91	VEP2BF2	123
V12F12-SS-E	94	V6OF6	87	V6M6-SS	91	VEP2DC-A	123
V12M12	91	V8F8	87	V8M8	91	VEP2F2	123
V12M12-B	91	V8F8-B	87	V8M8-B	91	VEP2OF3	123
V12M12-E	96	V8F8-SS	87	V8M8-SS	91	VEP3BF3	123
V12M12-SS	91	V8BF8	87	V2M2-B-E	96	VEP3BF4	123
V12M12-SS-E	96	V8BF8-B	87	V2M2-E	96	VEP3DC-A	123
V16DC-A	97	V8BF8-SS	87	V2M2-SS-E	96	VEP3F3	123
V16F16-B-E	94	V8OF8	87	V3M3-E	96	VEP3F4	123
V16F16-E	94	V2F2-B-E	94	V3M3-B-E	96	VEP3OF4	123
V16F16-SS-E	94	V2F2-E	94	V3M3-SS-E	96	VEP4BF4	123
V16M16	91	V2F2-SS-E	94	V4M4-E	96	VEP4BF4-BOP	143
V16M16-B	91	V3F3-E	94	V4M4-B-E	96	VEP4BF6	123
V16M16-E	96	V3F3-B-E	94	V4M4-SS-E	96	VEP4DC-A	123
V16M16-SS	91	V3F3-SS-E	94	V6M6-E	96	VEP4F4	123
V16M16-SS-E	96	V3BF3-E	94	V6M6-B-E	96	VEP4F4-BOP	143
V2-BRKIT	99	V3BF3-B-E	94	V6M6-SS-E	96	VEP4F6	123
V2-RKIT	99	V3BF3-SS-E	94	V8M8-E	96	VEP4OF4	123
V2-SSRKIT	99	V4F4-E	94	V8M8-B-E	96	VEP4OF5	123
V2BF2	87	V4F4-B-E	94	V8M8-SS-E	96	VEP4OF6	123
V2BF2-B	87	V4F4-SS-E	94	V3-BRKIT	99	VEP6BF6	123
V2BF2-B-E	94	V4BF4-E	94	V3-RKIT	99	VEP6BF6-BOP	143
V2BF2-E	94	V4BF4-B-E	94	V3-SSRKIT	99	VEP6DC-A	123
V2BF2-SS	87	V4BF4-SS-E	94	V3DC-A	97	VEP6F6	123
V2BF2-SS-E	94	V6F6-E	94	V4-BRKIT	99	VEP6F6-BOP	143
V2DC-A	97	V6F6-B-E	94	V4-RKIT	99	VEP6OF6	123
V2F1	87	V6F6-SS-E	94	V4-SSRKIT	99	VEP8BF8	123
V2F2	87	V6BF6-E	94	V4DC-A	97	VEP8BF8-BOP	143
V2F2-B	87	V6BF6-B-E	94	V6-BRKIT	99	VEP8DC-A	123
V2F2-SS	87	V6BF6-SS-E	94	V6-RKIT	99	VEP8F8	123
V2OF2	87	V8F8-E	94	V6-SSRKIT	99	VEP8F8-BOP	143
V3F3	87	V8F8-B-E	94	V6DC-A	97	VEP8OF8	123
V3F3-B	87	V8F8-SS-E	94	V8-BRKIT	99	W10-BMF	127
V3F3-SS	87	V8BF8-E	94	V8-RKIT	99	W10-RKIT	128
V3BF3	87	V8BF8-B-E	94	V8-SSRKIT	99	W10BF10-B	127
V3BF3-B	87	V8BF8-SS-E	94	V8DC-A	97	W10DC	128
V3BF3-SS	87	V2JM2	92	VEP10BF10	123	W10F10-B	127
V3OF3	87	V3JM3	92	VEP10BF10-BOP	143	W12-BMF	127



## Alpha Numeric Product Index

Part #	Page #	Part #	Page #	Part #	Page #	Part #	Page #
W12-RKIT	128	WS6OF6	131				
W12BF12-B	127	WS8F8	131				
W12DC	128	WS8F8-SS	131				
W12F12-B	127	WS8BF8	131				
W6-BMF	127	WS8BF8-SS	131				
W8-BMF	127	WS8OF8	131				
W6-RKIT	128	WS6F4-BOP	145				
W6BF4-B	127	WS6F6-BOP	145				
W6BF6-B	127	WS6F6-SS-BOP	145				
W6DC	128	WS8BF8-BOP	145				
W8DC	128	WS8F8-BOP	145				
W6F4-B	127	WS8F8-SS-BOP	145				
W6F6-B	127						
W8F8-B	127						
W8F8	127						
W8BF8-B	127						
W8-RKIT	128						
WS10BF10	131						
WS10BF10-BOP	145						
WS10BF10-SS	131						
WS10DC-A	132						
WS10F10	131						
WS10F10-BOP	145						
WS10F10-SS	131						
WS10F10-SS-BOP	145						
WS10OF10	131						
WS12BF12	131						
WS12BF12-BOP	145						
WS12BF12-SS	131						
WS12DC-A	132						
WS12F12	131						
WS12F12-BOP	145						
WS12F12-SS	131						
WS12F12-SS-BOP	145						
WS12OF12	131						
WS16BF16	131						
WS16BF16-BOP	145						
WS16BF16-SS	131						
WS16DC-A	132						
WS16F16	131						
WS16F16-BOP	145						
WS16F16-SS	131						
WS16F16-SS-BOP	145						
WS16OF16	131						
WS6BF6	131						
WS6BF6-BOP	145						
WS6BF6-SS	131						
WS6DC-A	132						
WS8DC-A	132						
WS6F4	131						
WS6F6	131						
WS6F6-SS	131						

# Part Number Structure

**F**

**4**

**H**

**F**

**4**

**B**

**E**

**LS**

**7**

### Body Size

1	1/8"
1.25	4mm
1.5	3/16"
1.88	6mm
2	1/4"
2.5	5/16"
2.83	9mm
3	3/8"
4	1/2"
5	5/8"
6	3/4"
8	1"
10	1-1/4"
12	1-1/2"
16	2"
20	2-1/2"
24	3"

### End Size

1	1/8"
1.25	4mm
1.5	3/16"
1.88	6mm
2	1/4"
2.5	5/16"
2.83	9mm
3	3/8"
4	1/2"
5	5/8"
6	3/4"
8	1"
10	1-1/4"
12	1-1/2"
16	2"
20	2-1/2"
24	3"

### Materials

A	Aluminum
B	Brass
NB	Naval Brass
SB	Stress Relieved Brass
S	303 Stainless Steel
SS	316 Stainless Steel
SN	Nitronic Stainless
P	Plastic

Standard material is steel.  
No designation is necessary for standard steel configurations.

### Valve Options

E	Unvalved (no valve)
V	Valved
BV	Brass Valve
SV	303 SS Valve
SSV	316 SS Valve
PV	Poppet Valve
VA	Valve Actuator
HV	Heavy Duty Valving
TV	Tube Valve
BTV	Brass Tube Valve
RV	Prong Valve

### Seals

F	FKM™
P	EPDM
E	Neoprene
S	Silicone
U	Urethane
H	Aflas™
K4	Kalrez® 4079
K6	Kalrez® 6375
K7	Kalrez® 7075
M	Military Low Temp Nitrile
JF	Hydrocarbon Fuel Nitrile
T	PTFE
TS	PTFE / Silicone
D	FDA FKM™
FS	Fluorosilicone
PS	EPDM (steam)
M1	Nitrile (FDA)
C	Celazole Back-up
CZ	Chemrez

Standard seal is Nitrile. No designation is necessary for standard Nitrile seal configurations.

### Product Series

A	Perfecting Astronautics High Pressure Pneumatic
AG	Agricultural Interchange Hydraulic
BR	Rectus 21 Interchange
CJ	European High Flow Interchange
CM	Mold Coolant Interchange
CVV	European Screw Together
DF	Industrial Interchange Pneumatic
E	Straight-Through Pressure Wash Interchange
EA	Straight-Through Water-Blast Interchange
H	ISO-B Industrial Interchange
HS	ISO-B Steam Interchange
HT	ISO16028 Flushface Interchange
J	Truflate Automotive Interchange
K	ISO-A Mobile Interchange
L	Lincoln Long-Stem Interchange
M	ARO 210/310 Interchange
N	Bowes Interchange
NK	Japanese Industrial Interchange
P	Thor Interchange
SCV	Excessive Flow Sensor/Safety Check Valve
ST	Snap-Tite 71 Flushface Interchange
SHD	Rectus 17/Schrader Interchange
T	High Pressure Screw Together
TR	TEMA European Interchange
U	Universal Pneumatic Combo-Couplers
V	Snap-Tite H/IH Hydraulic Interchange
VEP	Stucchi VEP Hydraulic Interchange
W	Wingstyle Interchange
WS	High Pressure Wingstyle

### End Connection

F	Female NPT(F)
M	Male NPT(F)
BF	Female BSPP
BM	Male BSPT
GM	Male BSPP
OF	Female ORB
OM	Male ORB
JF	Female 37° JIC
JM	Male 37° JIC
JB	Male Bulkhead 37° JIC
RM	Male ORFS
RB	Bulkhead ORFS
P	Tube Fitting
S	Hose Barb
4S	45° Hose Barb
9S	90° Hose Barb
CS	Collar Hose Barb
B	Push-Loc Barb
4B	45° Push-Loc Barb
9B	90° Push-Loc Barb
FM	Female Metric
MM	Male Metric
MBM	Metric Bulkhead

### Sleeve Options

LS	Locking Sleeve
BLS	Brass Locking Sleeve
ZLS	Steel Locking Sleeve
XLS	303 SS Locking Sleeve
YLS	316 SS Locking Sleeve
FS	Flanged Sleeve
BFS	Brass Flanged Sleeve
FLS	Flanged Locking Sleeve
ZFS	Steel Flanged Sleeve
FSB	Silicone Fryer Boot
BS	Brass Sleeve
ZS	Steel Sleeve
XS	303 SS Sleeve
YS	316 SS Sleeve
PTC	Push-To-Connect Sleeve
TG	Thermal Guard Sleeve
PL	Automatic Latch Pin
PB	Automatic Ball Latch
TG	Thermal Guard Sleeve
HN	Hex Nut Sleeve
HNS	303 SS Hex Nut Sleeve
TP	Tangle Prevention
FNS	Flanged Nylon Sleeve
NLS	No Locking Sleeve

### Other Options

4	Black Oxide Plating
7	Bright Nickel Plating
8	Electroless Nickel Plating
9	PTFE Coating
10	Standard Nickel Plating
11	Chrome over Nickel
BMF	Flange Mount Bracket
C1	Oxygen Clean
HL	Extended Hex
L##	Length
WF	Wrench Flats

### To Designate Couplers

Body size numerical designation precedes coupling series alpha designation. Example: 2HF2 (1/4" ISO-B Coupler)

### To Designate Nipples

Coupling series alpha designation precedes body size numerical designation. Example: H2F2 (1/4" ISO-B Nipple)

FKM™ is a trademark of Dupont/Dow Elastomers  
Kalrez® is a trademark of Dupont/Dow Elastomers  
PTFE is a trademark of Dupont  
Aflas® is a trademark of Asahi Glass Limited



Many variations of the part numbers contained within this guide can be ordered utilizing the format shown above. However, some variations may require minimum order quantities, longer lead times, and/or price adjustments based upon the uniqueness of construction. Please contact your Dixon Quick Coupling representative for details regarding your particular coupling configuration

## Limited Warranty

Dixon Quick Coupling (herein called "Dixon") warrants the products described herein, and manufactured by Dixon to be free from defects in material and workmanship for a period of one (1) year from date of shipment by Dixon under normal use and service. Its sole obligation under this warranty being limited to repairing or replacing, as hereinafter provided, at its option any product found to Dixon's satisfaction to be defective upon examination by it, provided that such product shall be returned for inspection to Dixon's factory within three (3) months after discovery of the defect. The repair or replacement of defective products will be made without charge for parts or labor. This warranty shall not apply to: (a) parts or products not manufactured by Dixon, the warranty of such items being limited to the actual warranty extended to Dixon by its supplier; (b) any product that has been subject to abuse, negligence, accident, or misapplication; (c) any product altered or repaired by others than Dixon; and (d) to normal maintenance services and the replacement of service items (such as washers, gaskets and lubricants) made in connection with such services. To the extent permitted by law, this limited warranty shall extend only to the buyer and any other person reasonably expected to use or consume the goods who is injured in person by any breach of the warranty. No action may be brought against Dixon for an alleged breach of warranty unless such action is instituted within one (1) year from the date the cause of action accrues. This limited warranty shall be construed and enforced to the fullest extent allowable by applicable law.

Other than the obligation of Dixon set forth herein, Dixon disclaims all warranties, express or implied, including but not limited to any implied warranties of merchantability or fitness for a particular purpose, and any other obligation or liability. The foregoing constitutes Dixon's sole obligation with respect to damages, whether direct, incidental or consequential, resulting from the use or performance of the product.

Some Products and Sizes May Be Discontinued When Stock Is Depleted, Or May Require A Minimum Quantity For Ordering

NOTE: Reasonable care has been taken in preparing this Illustrated Price List. Dixon Quick Coupling reserves the right to make corrections and price changes.

NOTE: Because of the health hazards associated with contamination and lead content in drinking water systems, Dixon couplings, unless otherwise specifically approved, are not recommended for potable water service and should not be used in applications where drinking water will contact the wetted surfaces of the coupling.

## General Information

Learn how to  
safely select and install  
quick disconnect couplings.

Safety & Selection	2
Thread Identification	4
Glossary	5
Installation Guide	6
Fluid Compatibility	11

## Pneumatic Couplings

A-series	55
BR-series	53
CJ-series	31
DF-series	12
J-series	22
L-series	37
M-series	27
N-series	41
NK-series	51
P-series	48
SCV-series	58
SHD-series	34
U-series	39

## Hydraulic Couplings

AG-series	79
CM-series	156
CVV-series	137
E-series	148
EA-series	154
H-series	60
H-BOP series	146
HS-series	71
HT-series	102
HTE-series	110
K-series	74
PD-series	119
ST-series	113
T-series	134
TR-series	100
V-series	83
VEP-series	121
VEP-BOP-series	142
W-series	124
WS-series	129
WS-BOP-series	144

## Coupling Search

*Dixon Quick Coupling is  
striving to provide the most  
complete competitive  
interchange guide.  
If you don't see your part,  
please call 800-839-8980.*

Index	164
Number Structure	176

## United States

**Albany, NY**  
ph 518.725.0998  
178A Corporate Drive  
Gloversville, NY 12078  
fx 518.725.8542

**Atlanta, GA**  
ph 770.486.9619  
101 T.D.K. Boulevard  
Suite A  
Peachtree City, GA 30269  
fx 770.486.9813

**Chestertown, MD**  
ph 800.355.1991  
800 High Street  
Chestertown, MD 21620  
fx 800.283.4966

**Chicago, IL**  
ph 630.323.3716  
40 Chestnut Avenue  
Westmont, IL 60559  
fx 630.323.4120

**Cleveland, OH**  
ph 330.425.3000  
1900 Enterprise Parkway  
Twinsburg, OH 44087  
fx 330.425.1527

**Houston, TX**  
ph 713.678.4291  
6525 Homestead Road  
Houston, TX 77028  
fx 713.678.8105

**Kansas City, MO**  
ph 816.221.0064  
1244 Saline Street  
N. Kansas City, MO 64116  
fx 816.221.1108

**Los Angeles, CA**  
ph 909.605.6400  
8840 Flower Road  
Suites150/160  
Rancho Cucamonga, CA 91730  
fx 909.605.6200

**Portland, OR**  
ph 503.289.0400  
2642 North Marine Drive  
Portland, OR 97217  
fx 503.289.0600

**Salt Lake City, UT**  
ph 801.972.1180  
McGillis Ind. Pk. Bldg., #4  
1972 South 4370 West  
Salt Lake City, UT 84104  
fx 801.972.8063

**Tampa, FL**  
ph 813.247.3500  
5120 Adamo Drive  
Suite E  
Tampa, FL 33619  
fx 813.247.7910

## International

**Edmonton, Alberta,  
Canada**  
ph 780.469.5444  
fx 780.463.9205

**Innisfil, Ontario,  
Canada**  
ph 705.436.1125  
fx 705.436.6251

**Montreal, Quebec,  
Canada**  
ph 514.422.9292  
fx 514.422.0166

**Wingfield SA,  
Australia**  
ph 61.8.8202.6000  
fx 61.8.8202.6099

**Preston, England**  
ph 44.1.77.232-3529  
fx 44.1.77.231.4664

**Troisdorf-Spich,  
Germany**  
ph 49.2241.84406.0  
ph 49.2241.8440679

**Monterrey, Mexico**  
ph 52.81.8354.5649  
fx 52.81.8354.8197

**FLOWTEKNIK**  
SCANDINAVIA APS

**RG**

**RUGVÆNGET 1 90**  
**2600 TAASTRUP**  
**INFO@PGFLOWTEKNIK.DK**  
**WWW.PGFLOWTEKNIK.DK**



dixonvalve.com



customer service

